

RS

**GIRANTE VORTEX
VORTEX IMPELLER**

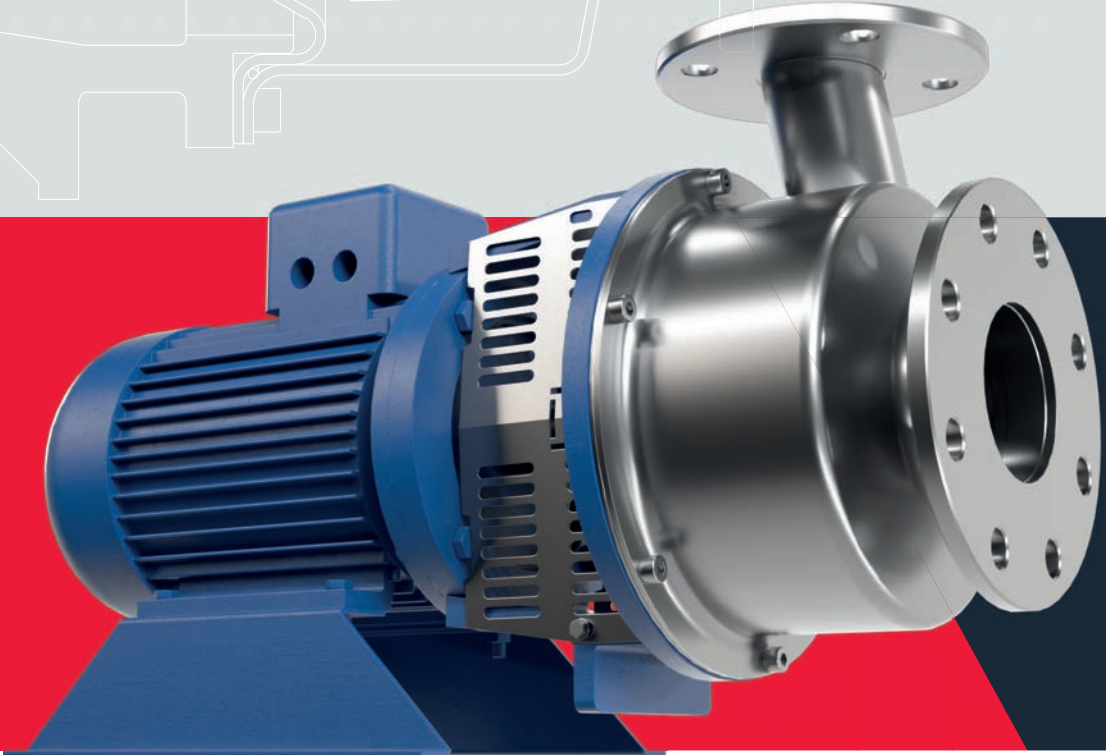

Le pompe centrifughe della serie RS sono pompe monostadio con girante posizionata in modo arretrato all'interno del corpo. Questa configurazione consente alla maggior parte del liquido di attraversare la pompa senza entrare direttamente in contatto con la girante.

Tale caratteristica offre notevoli vantaggi sia nel trasportare, senza causare danni, elementi come cristalli, solidi delicati, prodotti vegetali, fiocchi di fanghi biologici e parti di pellame, sia nel convogliare solidi lunghi e filamentosi senza rischio di intasamenti.

La girante vortex è in grado di gestire miscele contenenti fino al 20% di gas o aria, rendendo queste pompe adatte per applicazioni in cui l'arrivo del liquido è altamente discontinuo.

Le pompe RS si distinguono per le loro prestazioni eccellenti anche nel trasferimento di prodotti viscosi con viscosità fino a 700 cPs.

La serie dispone di una versione con raccordi alimentari secondo DIN 11851, che può essere fornita anche con motore carenato.

L'eccezionale flessibilità e la vasta gamma di scelta dei sistemi di tenuta rende questa serie adatta per impieghi complessi.

Centrifugal pumps belonging to the RS series are single-stage pumps with a recessed impeller within the casing. This configuration allows most of the liquid to pass through the pump without coming into direct contact with the impeller.

This feature offers significant advantages in transporting various elements such as crystals, delicate solids, agricultural products, biological sludge flakes, and leather residues without causing damage, as well as in conveying long and filamentous solids without the risk of clogging.

The vortex impeller is capable of handling mixtures containing up to 20% of gas or air, making these pumps suitable for applications where the suction of the liquid is highly intermittent.

RS pumps are known for their excellent performance even in transferring sticky products with viscosities up to 700 cPs. A version with food-grade connections according to DIN 11851 is available and it can be supplied with a shrouded motor as well.

The exceptional flexibility and wide range of choices for sealing arrangements make this series suitable for complex applications.

RS

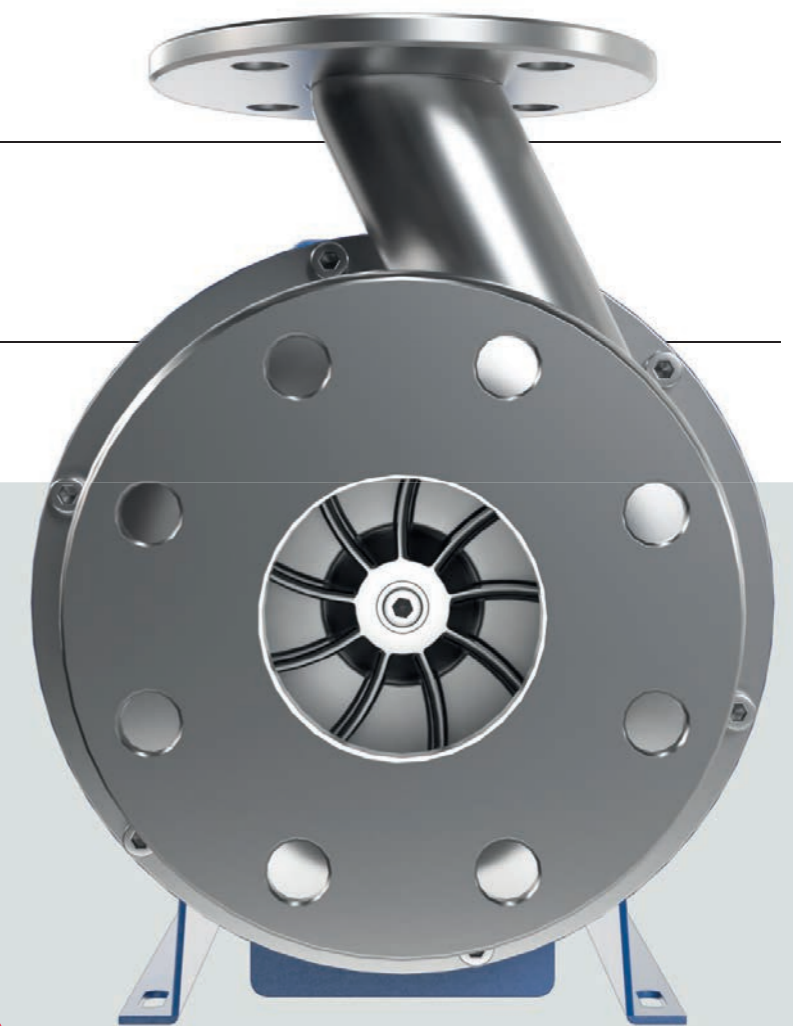

Tutti i diritti sono riservati, anche per quanto riguarda l'eventuale cessione, riproduzione, modifica, distribuzione dei dati. Tutti i marchi, i diritti di proprietà sono di proprietà della Società. La nostra politica è quella del miglioramento continuo del prodotto. Salvatore Robuschi Pumps si riserva il diritto di modificare i propri prodotti senza preavviso.

I dati riportati in questo catalogo, hanno lo scopo primario di descrivere il prodotto.

Dalle informazioni non è possibile dedurre alcuna conferma relativa a condizioni di funzionamento o idoneità per una specifica applicazione. Le informazioni fornite non esonerano l'utente dall'obbligo e dalla responsabilità del proprio giudizio e verifica.

All rights reserved, also regarding any disposal, reproduction, editing, distribution of data.

All trademarks and the property rights are property of the Company. Our policy is one of continuous product improvement. Salvatore Robuschi Pumps reserves the right to modify its products without prior notice.

The data reported in this catalogue have the primary purpose of describing the product. No confirmation regarding operating conditions or suitability for a specific application can be deduced from these information.

The information provided by the Company does not release the user from the obligation of own judgment and verification.

IMPIEGHI

- **Industria alimentare** per trasferimento di liquidi con solidi sospesi, lavaggio frutta e ortaggi, lavaggi CIP, carico e scarico autocisterne, ecc.
- **Impianti biodiesel e Bioetanolo.**
- **Trattamento acque** per liquidi con solidi sospesi anche filamentosi, fanghi biologici e flocculati, latte di calce, sistemi di flottazione con aria fino al 15%.
- **Industria chimica e Farmaceutica di base.**
- **Industria tessile** per bagni chimici e salamoie.
- **Industria conciaria** per bagni chimici con sospensione di solidi e filamenti.

PASSAGGIO LIBERO

La gamma comprende pompe con bocche di mandata fino a 65 mm con passaggio libero di 50 mm.

VERSATILITÀ

6 varianti di sede tenuta per adattarsi ad ogni esigenza d'impianto.

MANUTENZIONE

Motori elettrici unificati per facilitare la manutenzione.

CONNESSIONI

- 1) Flange con interasse secondo EN 1092.
- 2) Connessioni alimentari DIN 11851 o altre a richiesta.

USE

- **FOOD INDUSTRY:** to transfer liquids with suspended solids, fruit and vegetables, washing, CIP systems, tanker truck load and unload, etc...
- **Biodiesel and Bio-ethanol plants.**
- **Water treatment** for liquids with suspended solids, also filamentous, biological sludge, flocculated sludge, calcium hydroxide, flotation systems with 15% air (as maximum).
- **Chemical and Basic pharmaceutical industry.**
- **Textile industry** for chemical baths and brine.
- **Tannery industry** for chemical baths with suspended solids and filaments.

FREE PASSAGE

This series includes pumps with a discharge port up to 65 mm and free passage of 50 mm.

FLEXIBILITY

6 different seal seat arrangement allow these pumps to be used for any plant needs.

MAINTENANCE

Standardized electric motors in order to simplify maintenance.

CONNECTIONS

- 1) Flanges with centre distances according to EN 1092.
- 2) Food connections DIN 11851 or others on request.

1

PASSAGGIO LIBERO DI SOLIDI

Passaggio libero fino al 70% del diametro della bocca di mandata: grazie alla sua disposizione arretrata, la girante consente un passaggio di corpi solidi sferici fino al 70% del diametro della bocca di mandata (vedere tabelle tecniche per ulteriori dettagli). Solidi filamentosi e di notevole lunghezza attraversano la pompa senza causare ostruzioni.

2

DESIGN DEL CORPO

L'assenza di interruzioni nelle superfici interne del corpo pompa previene la formazione di zone di accumulo e i componenti più soggetti all'usura sono stati dimensionati con cura per garantire prestazioni durevoli e affidabili nel tempo.

3

MOTORE ELETTRICO UNIFICATO

I motori utilizzati sulle pompe della serie RS sono unificati secondo standard IEC tipo B3B5 (esecuzione con flangia e piedi) e facilmente reperibili sul mercato. L'albero della pompa è calettato sopra quello del motore e può essere facilmente sostituito in caso di usura.

SOLID FREE PASSAGE

Free passage up to 70% of the discharge port diameter: thanks to its recessed arrangement, the impeller allows the passage of spherical solid bodies up to 70% of the discharge port diameter (see technical tables for further details). Long and filamentary solids pass through the pump without any risk of clogging.

CASING DESIGN

The inner smooth surface of the pump casing avoids material build-up and dimensions of components prone to wear have been accurately studied to guarantee a long-lasting and reliable performance.

STANDARD ELECTRIC MOTOR

RS pumps motors are unified according to IEC standard type B3B5 (flange/feet execution) and they are easily available on the market. The pump shaft is fixed on the motor one and it can be easily replaced in case of wear.

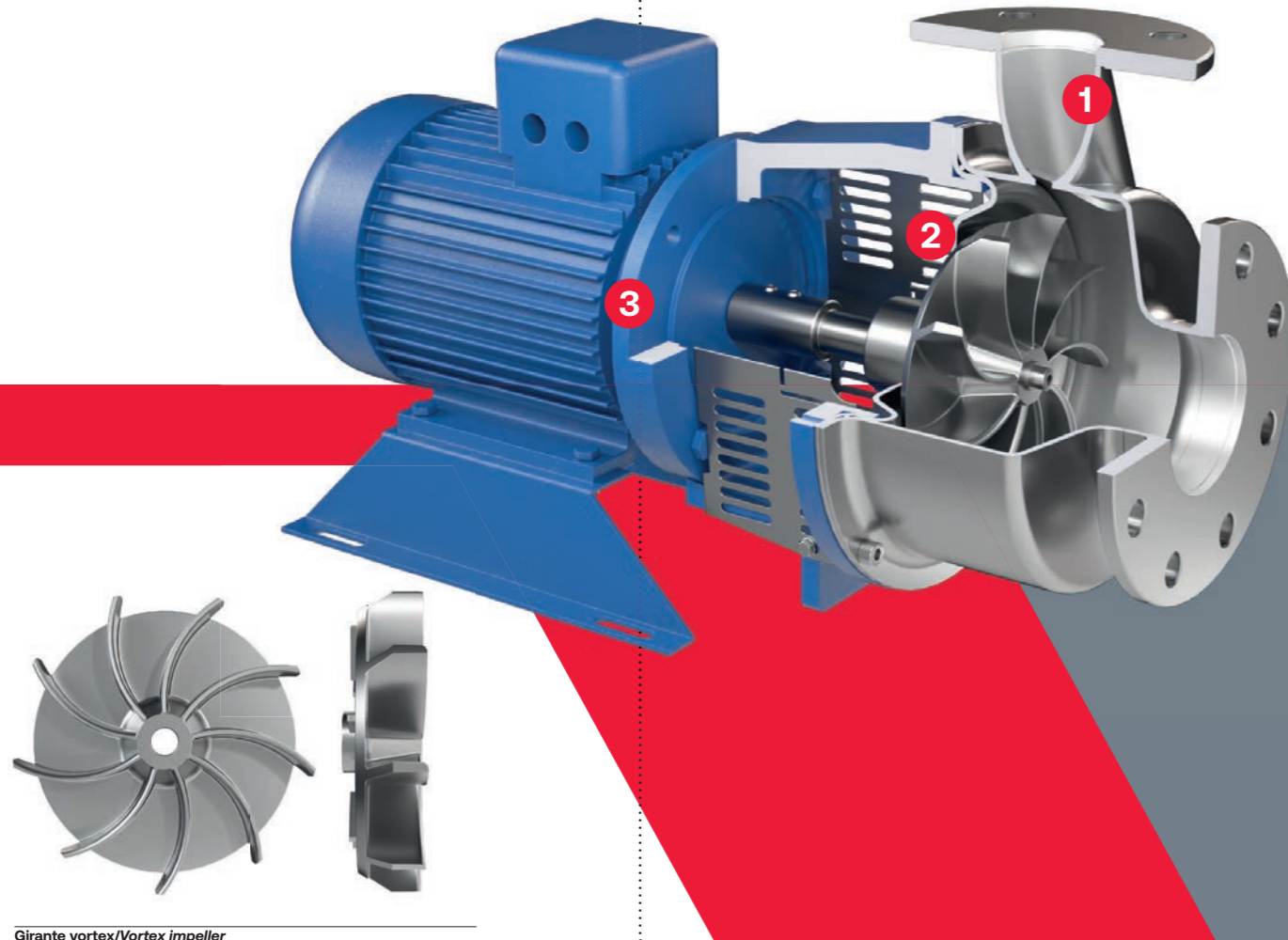

Girante vortex/Vortex impeller

- Dimensioni bocca di mandata
Da 3/4" M a DN 65
- Pressione massima di esercizio
Fino a 8 bar – in base alla taglia della pompa
- Portata
Fino a 100m³/h
- Prevalenza
Fino a 60 m
- Temperatura
Fino a 120°C in funzione del liquido pompato
- Flange
Forate secondo EN 1092 PN10, attacchi alimentari DIN 11851, a richiesta forate ANSI B16.5 150#
- Materiali
Standard: AISI 316

- Discharge sizes
From 3/4" M to DN 65
- Maximum working pressure
Up to 8 bar – according to the pump size
- Flow rate
Up to 100 m³/h
- Differential head
Up to 60 m
- Temperature
Up to 120°C according to the pumped liquid
- Flanges
EN 1092 PN10 drilled, DIN 11851 food connections or ANSI B16.5 150# drilled on request
- Materials
Standard: AISI 316

Sigla di identificazione
Identification markGirante vortex
Vortex impeller

1	2	3	4	5	6	7	8	9
RSM	50 20	A	4	A75	C	181	3	A

1 Esecuzione pompa

RSM	Pompa monoblocco con flange EN 1092-1
RSA	Pompa monoblocco con attacchi DIN 11851
RSS	Pompa monoblocco con attacchi fuori standard

1 Pump arrangement

RSM	Closed coupled pump with flange EN 1092-1
RSA	Closed coupled pump with DIN 11851 connection
RCM	Closed coupled pump with not standard connection

2 Grandezza pompa

50-20	
50	Diametro bocca di mandata (mm)
20	Diametro Nominale Girante (cm)

2 Pump size

50-20	
50	Discharge port diameter (mm)
20	Nominal impeller diameter (cm)

3 Riduzione girante

A	Diametro massimo
B	1° riduzione
C	2° riduzione
AR	Riduzione intermedia (tra A e B)

3 Impeller trim

A	Maximum diameter
B	1° trim
C	2° trim
AR	Intermediate trim (between A and B)

4 Polarità motore

2	Motore elettrico a 2 poli
4	Motore elettrico a 4 poli
6	Motore elettrico a 6 poli
8	Motore elettrico a 8 poli

4 Motor polarity

2	2 poles electric motor
4	4 poles electric motor
6	6 poles electric motor
8	8 poles electric motor

5 Potenza motore elettrico

A	0,25-0,75 kW
B	1,1-9,2 kW
C	11-90 kW
D	110-400 kW

5 Electric motor power

A	0.25-0.75 kW
B	1.1-9.2 kW
C	11-90 kW
D	110-400 kW

A	kW	0,25	0,37	0,55	0,75
	Cod	A25	A37	A55	A75

B	kW	1,1	1,5	2,2	3,0	4,0	5,5	7,5	9,2
	Cod	B11	B15	B22	B30	B40	B55	B75	B92

C	kW	11	15	18,5	22	30	37	45	55	75	90
	Cod	C11	C15	C18	C22	C30	C37	C45	C55	C75	C90

D	kW	110	132	160	200	225	250	280	315	355	400
	Cod	D11	D13	D16	D20	D22	D25	D28	D31	D35	D40

6 Sistema di tenuta

Esecuzione M	Tenuta meccanica singola
Esecuzione B	Tenuta a baderna senza flussaggio
Esecuzione S	Tenuta a baderna con flussaggio (solo in ingresso)
Esecuzione H	Camera di riscaldamento o raffreddamento
Esecuzione C	Tenuta meccanica doppia contrapposta
Esecuzione L	Tenuta meccanica doppia in tandem
Esecuzione A	Tenuta meccanica singola con bussola di fondo

6 Sealing system

M Execution	Single mechanical seal
B Execution	Gland packing without flushing
S Execution	Gland packing with flushing (inlet only)
H Execution	Heating or cooling chamber
C Execution	Double back to back mechanical seal
L Execution	Double tandem mechanical seal
A Execution	Single mechanical seal with throttle bushing

7 Codice tenuta meccanica primaria

Nota
Per esecuzioni B e S = 000

7 Primary mechanical seal Code

Note
For B and S executions = 000

8 Codice componenti principali della pompa

Per maggiori dettagli vedere la tabella T-2177 Codifica materiali

8 Identification code for pump's parts

For more details see table T-2177 Materials code

9 Indice di revisione idraulica

9 Hydraulic release index

Dati tecnici
Technical featuresGirante vortex
Vortex impeller

Descrizione Description	Unità di misura Unity of measurement	Grandezze Size											
		20-08	25-12	32-12	40-12	32-16	40-16	50-16	65-16	32-20	40-20	50-20	65-20
Gruppo pompa Pump group		RS1	RS2		RS3			RS4					
Corpo Casing													
Pressione di progetto Design pressure	bar	4	6			8					6		
Foro drenaggio Casing drain	A richiesta On request												
Girante Impeller													
Numero di pale Blade number	mm	6	6	6	6	9	9	9	9	6	6	9	9
Passaggio sferico RS/RSA Max.sphere RS/RSA	mm	12	15	22	30	22	30	40	50	5	6	40	50
Momento di inerzia J ^(a) Moment of inertia J ^(a)	kgm ²	0,01	0,01	0,01	0,01	0,01	0,01	0,01	0,01	0,02	0,02	0,02	0,02
Cassa stop Seal chamber													
Dia. tenuta meccanica Mechanical seal diameter	mm	24					33						
Camera di raffreddamento Cooling jacket													
Pressione max Max.pressure	bar	-	3										
Pressione di prova Max.hydrostatic pressure	bar	-	4,5										
Connessioni Connections holes		G.1/4											
Potenza max Max Power													
Potenza max 2.900 rpm Max Power 2.900 rpm	kW	0,55	5,5			15			15				
Potenza max 1.450 rpm Max Power 1.450 rpm	kW	0,37	4			7,5			7,5				
Potenza max 960 rpm Max Power 960 rpm	kW	0,25	2,2			5,5			5,5				
Forma mot. elettrico El, motor shape													
kW 0,55 / 2 poli Size 71		B34			-								
kW 0,75 - 1,1 - 1,5 - 2,2 / 2 poli Size 80 / 90		-	B5			-							
kW 3 - 4 / 2 poli Size 100 / 112		-	B3B5			-							
kW 5,5 - 7,5 - 9,2 - 11 / 2 poli Size 132		-	B3B5			-							
kW 0,37 / 4 poli Size 71		B34			-								
kW 0,55 - 0,75 - 1,1 - 1,5 / 4 poli Size 80 / 90		-	B5			B3B5							
kW 2,2 - 3 - 4 / 4 poli Size 100 / 112		-	B3B5			-							
kW 5,5 - 7,5 - 9,2 / 4poli Size 132		-	-			B3B5							

(a) Dividi per 1.000 per ottenere il momento di inerzia J in kgm²
Divide by 1.000 to obtain the moment of inertia J in kgm²

Per condizioni di lavoro diverse, consultate il nostro servizio tecnico commerciale.
Please contact SR pumps representative for specific working condition.

Dati tecnici
Technical features

Girante vortex
Vortex impeller

Esecuzione C
C execution

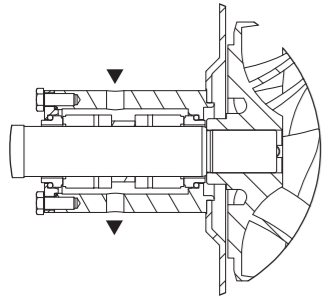

Esecuzione L
L execution

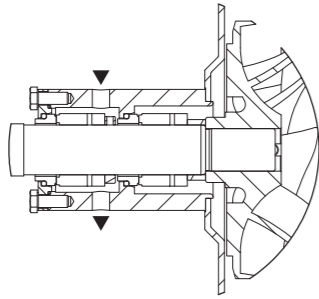

Flussaggio tenuta meccanica doppia esecuzione C - L
Double mechanical seal flushing C - L exec.

Gruppo Group	Dia. ten. mecc. Mech. seal dia. (mm)	Portata flussaggio Flushing capacity (l/min)		P di flussaggio Flushing pressure (bar)	
		2900 rpm	1450 rpm	C	L
RS2 - RS3	24	0,8	0,4	0,5 > p mandata 0,5 > discharge p	0,1 < P < 0,2
RS4	33	1,4	0,7		

Esecuzione H
H execution

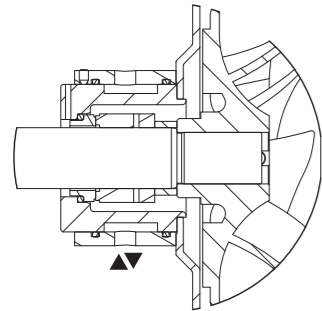

Flussaggio camera di raffreddamento esecuzione H
Cooling chamber flushing H execution

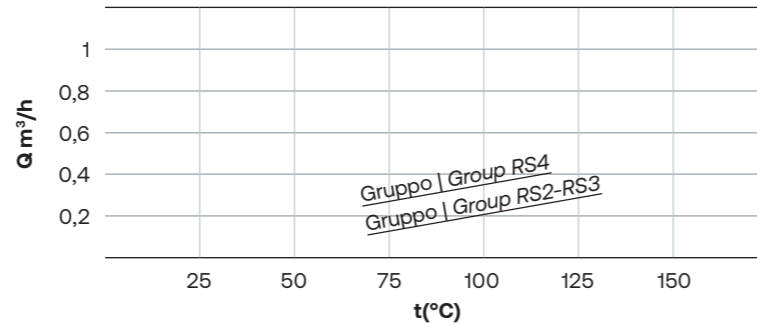

Esecuzione S
S execution

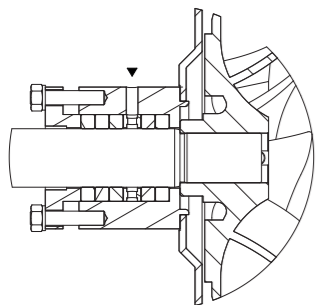

Flussaggio tenuta meccanica doppia esecuzione S
Double mechanical seal flushing S exec.

Gruppo Group	Dia. ten. mecc. Mech. seal dia. (mm)	Portata flussaggio Flushing capacity (l/min)		P di flussaggio Flushing pressure (bar)	
		2900 rpm	1450 rpm	S	
RS2 - RS3	24	0,8	0,4	0,5 > p mandata 0,5 > discharge p	
RS4	33	1,4	0,7		

Dati tecnici
Technical features

Girante vortex
Vortex impeller

Limiti di pressione
e di temperatura

Pressure
and Temperature Limits

In caso di forti rischi di corrosione i limiti possono anche essere inferiori a quelli indicati.

When the medium is very aggressive, limits can be even lower than the indicated values.

Per condizioni di lavoro diverse, consultate il nostro Servizio tecnico commerciale.

Please contact SR pumps representative for specific working condition.

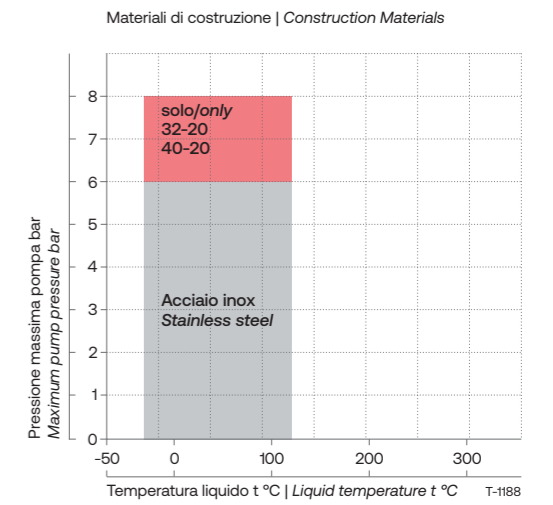

Descrizione	Description	Codice materiale pompa Pumps material code		
		3	8	S
Corpo	Casing	CF8M (AISI 316)	SAF 2507	A richiesta On demand
Coperchio del corpo	Casing cover	CF8M (AISI 316)	SAF 2507	A richiesta On demand
Girante	Impeller	CF8M (AISI 316)	SAF 2507	A richiesta On demand
Albero	Shaft	AISI 316L	SAF 2507	A richiesta On demand
Piede sostegno	Support foot	S 235 JR	S 235 JR	A richiesta On demand
Lanterna	Lantern bracket	AISI 304 / GJL 200	GJL 200	A richiesta On demand
Coperchio tenuta singola	Single mechanical seal cover	AISI 316L	SAF 2507	A richiesta On demand
Coperchio tenuta doppia	Double mechanical seal cover	AISI 316L	SAF 2507	A richiesta On demand
Ogiva girante	Impeller hub	AISI 316L	SAF 2507	A richiesta On demand

Tenuta singola (con e senza flussaggio)
Single seal (with or without flushing)



Tenuta contrapposta
Back to back mechanical seal



Tenuta baderna (con e senza flussaggio)
Packing gland (with or without flushing)

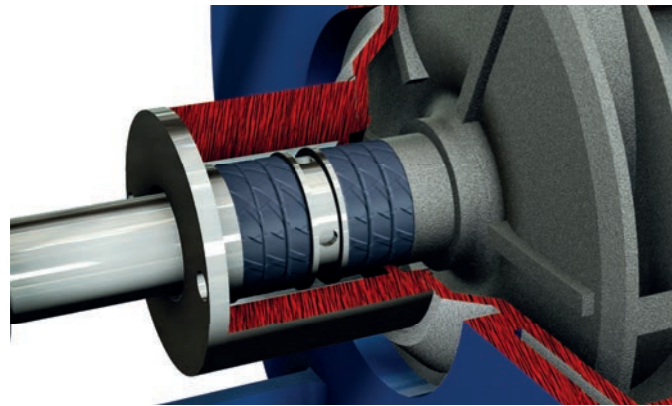

Tenuta in tandem
Tandem mechanical seal



Tenuta meccanica singola
Single mechanical seal

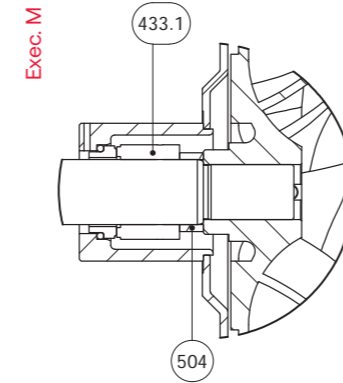

Singola flussata (con/senza bussola di fondo)
Single with flushing (with/without throttle-bush)

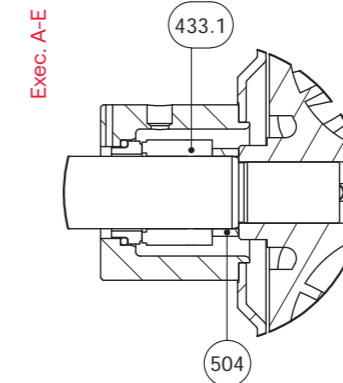

Tenuta a baderna
Packing gland

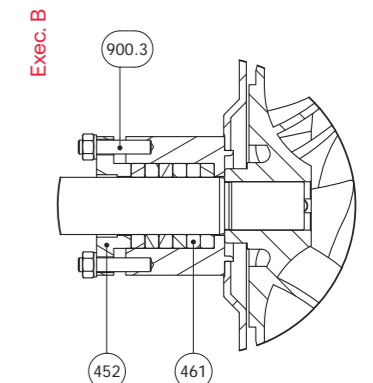

Tenuta a baderna flussata
Packing gland with flushing

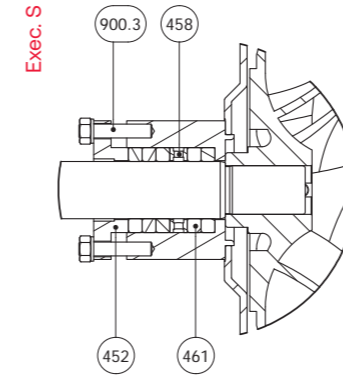

Tenuta meccanica doppia in tandem
Double tandem mechanical seal

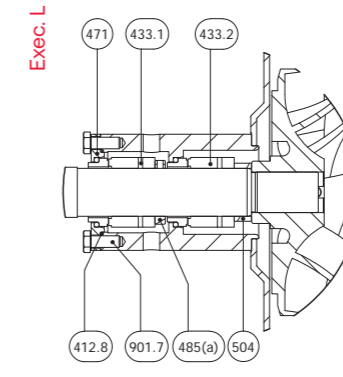

Tenuta meccanica doppia contrapposta
Double back to back mechanical seal

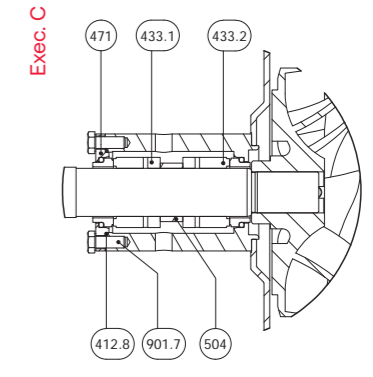

Camera riscaldamento/raffreddamento
Cooling/heating jacket

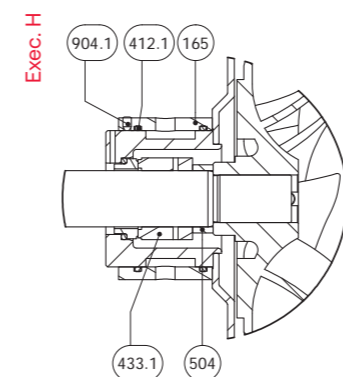

N.	Descrizione	Description
165	Coperchio camera di raffreddamento	Cooling chamber cover
452	Premitreccia	Packing gland
458	Anello idraulico	Lantern ring
461	Baderna	Packing ring
471	Coperchio tenuta meccanica	Seal chamber cover
485(a)	Anello arresto tenuta meccanica	Abutment ring
504	Distanziale	Spacer
412.1	O-ring	O-ring
412.8	O-ring	O-ring
433.1	Tenuta meccanica L.C.	Mechanical seal D.S.
433.2	Tenuta meccanica L.O.C.	Mechanical seal N.D.S.
900.3	Prigioniero con dado	Stud with nut
901.7	Vite T.E.	Hex head screw
904.1	Grano	Locking screw

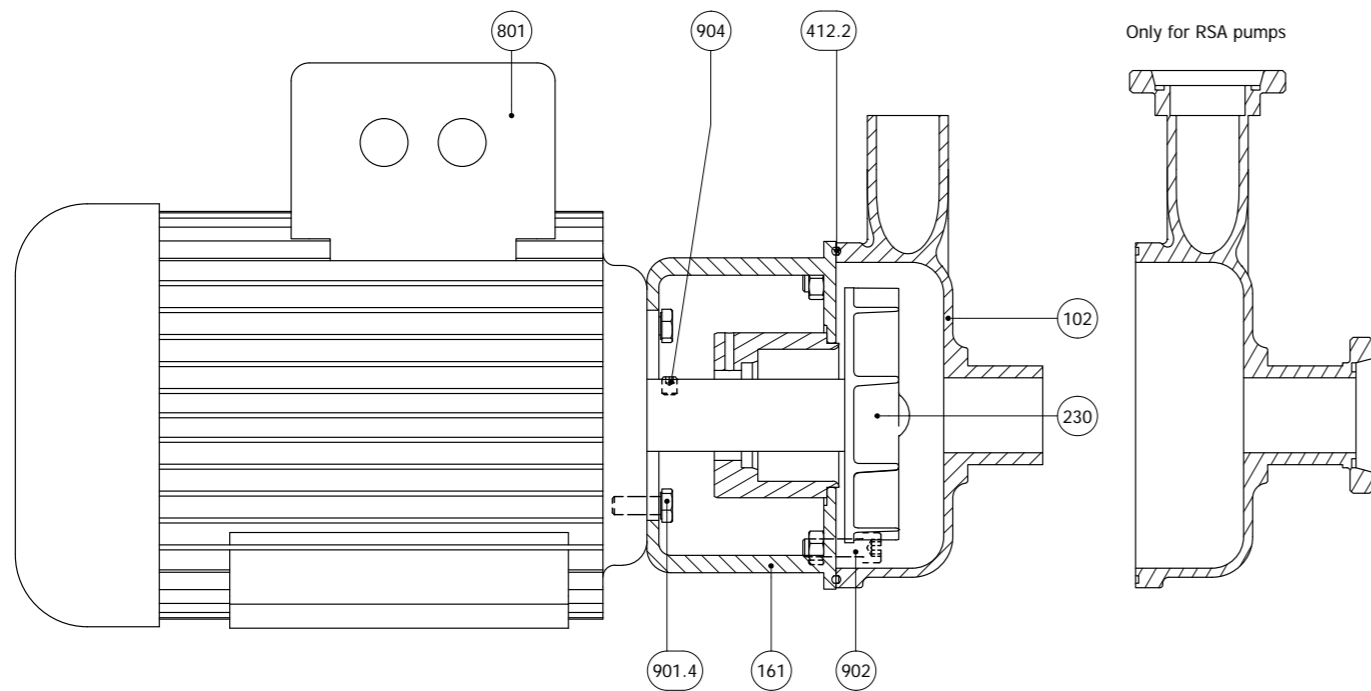

N.	Descrizione	Description
102	Corpo	Casing
161	Coperchio del corpo	Casing cover
230	Girante	Impeller
412.2	O-ring corpo	O-ring casing

N.	Descrizione	Description
801	Motore elettrico	Electric motor
902	Vite T.C.E.I.	Socket head screw
904	Grano	Locking screw
901.4	Vite T.E.	Hex head screw

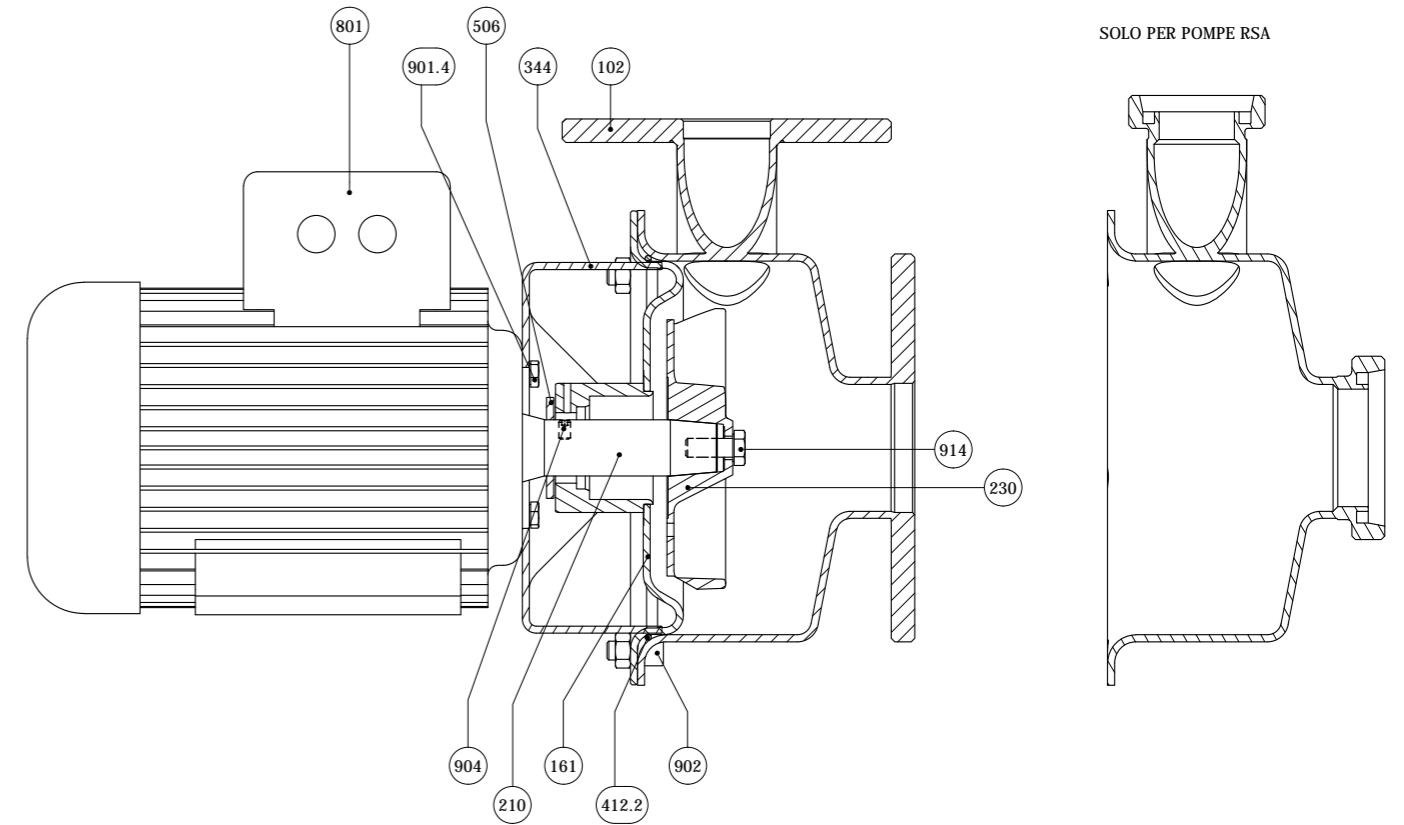

N.	Descrizione	Description
102	Corpo	Casing
161	Coperchio del corpo	Casing cover
210	Albero	Shaft
230	Girante	Impeller
344	Lanterna motore	Lantern bracket
412.2	O-ring corpo	O-ring casing

N.	Descrizione	Description
506	Anello paraspruzzi	Deflector
801	Motore elettrico	Electric motor
902	Vite T.C.E.I.	Socket head screw
904	Grano	Locking screw
914	Vite ogivale	Screw
901.4	Vite T.E.	Hex head screw

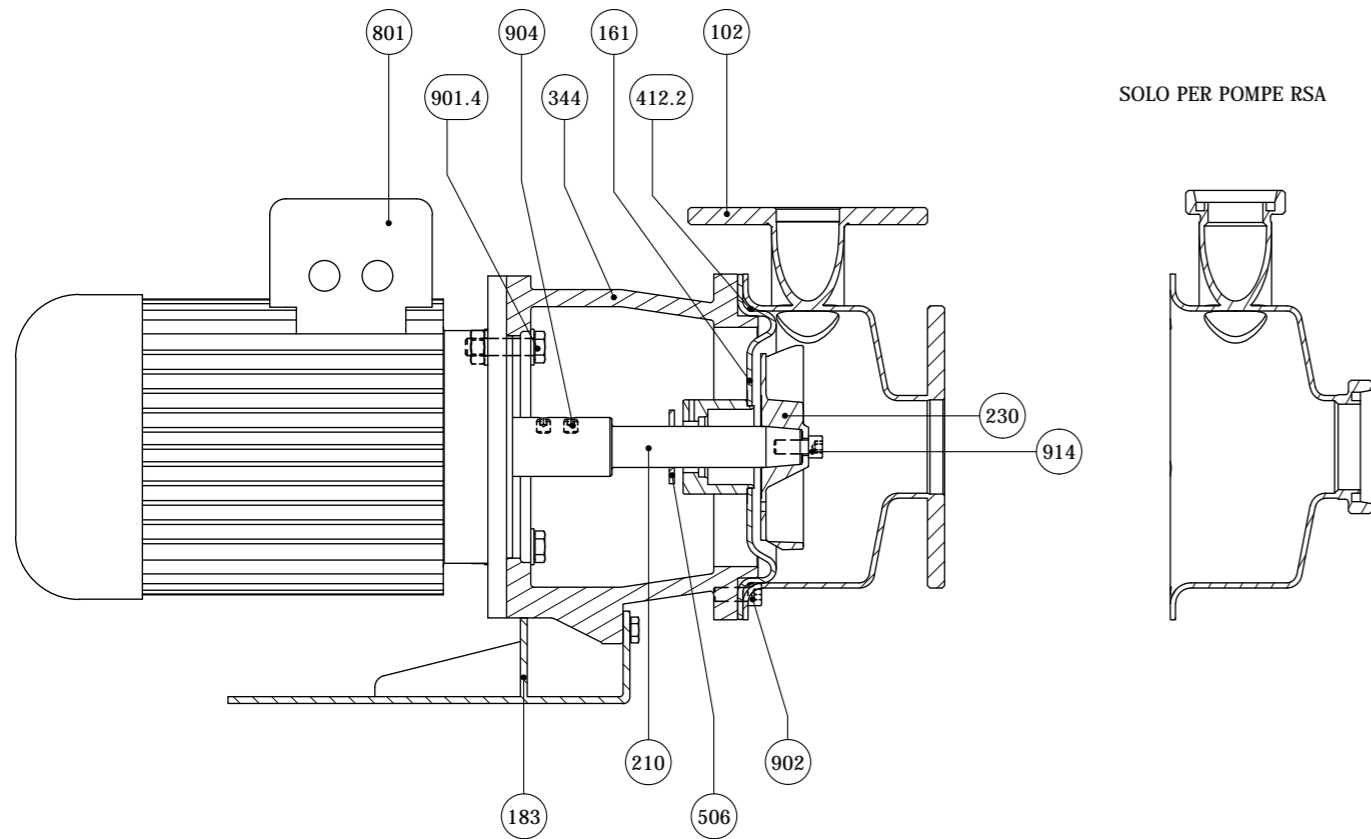

N.	Descrizione	Description
102	Corpo	Casing
161	Coperchio del corpo	Casing cover
183	Piede di appoggio	Support foot
210	Albero	Shaft
230	Girante	Impeller
344	Lanterna motore	Lantern bracket
412.2	O-ring corpo	O-ring casing

N.	Descrizione	Description
506	Anello paraspruzzi	Deflector
801	Motore elettrico	Electric motor
902	Vite T.C.E.I.	Socket head screw
904	Grano	Locking screw
914	Vite ogivale	Screw
901.4	Vite T.E.	Hex head screw

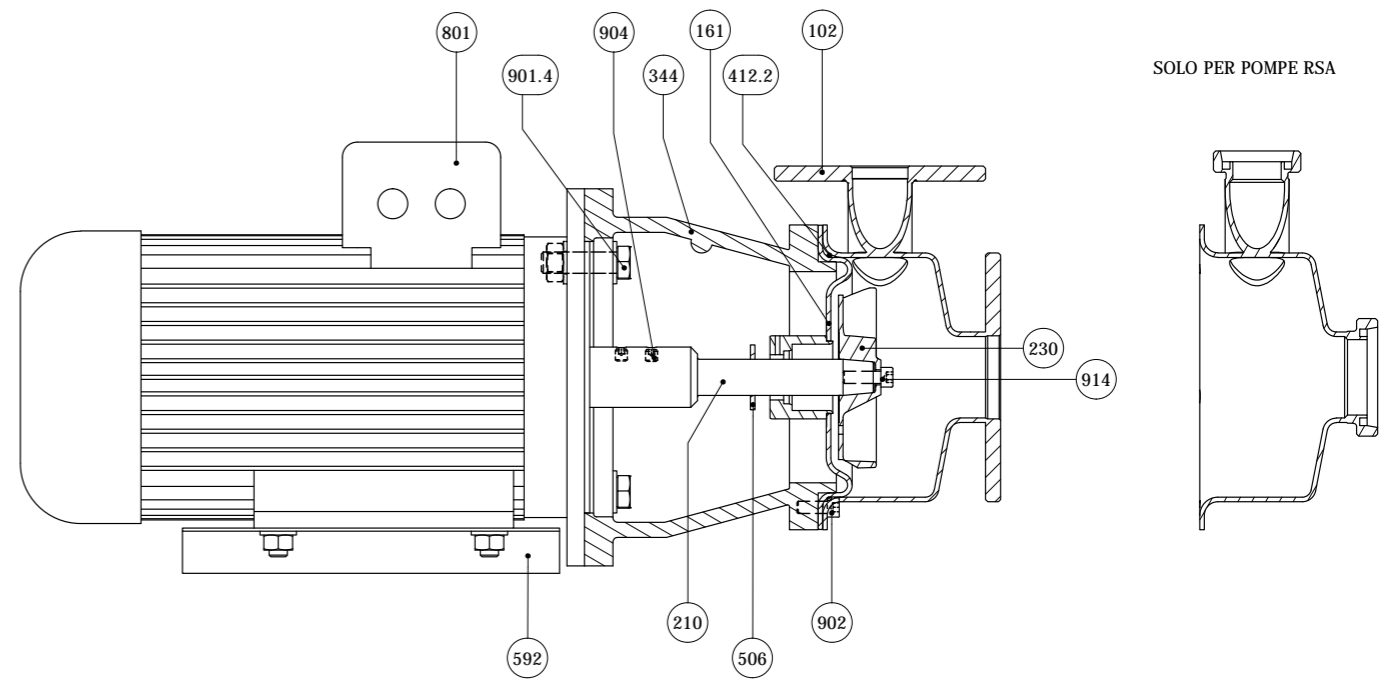

N.	Descrizione	Description
102	Corpo	Casing
161	Coperchio del corpo	Casing cover
210	Albero	Shaft
230	Girante	Impeller
344	Lanterna motore	Lantern bracket
412.2	O-ring corpo	O-ring casing
506	Anello paraspruzzi	Deflector

N.	Descrizione	Description
592	Piede motore	Electric motor foot
801	Motore elettrico	Electric motor
902	Vite T.C.E.I.	Socket head screw
904	Grano	Locking screw
914	Vite ogivale	Screw
901.4	Vite T.E.	Hex head screw

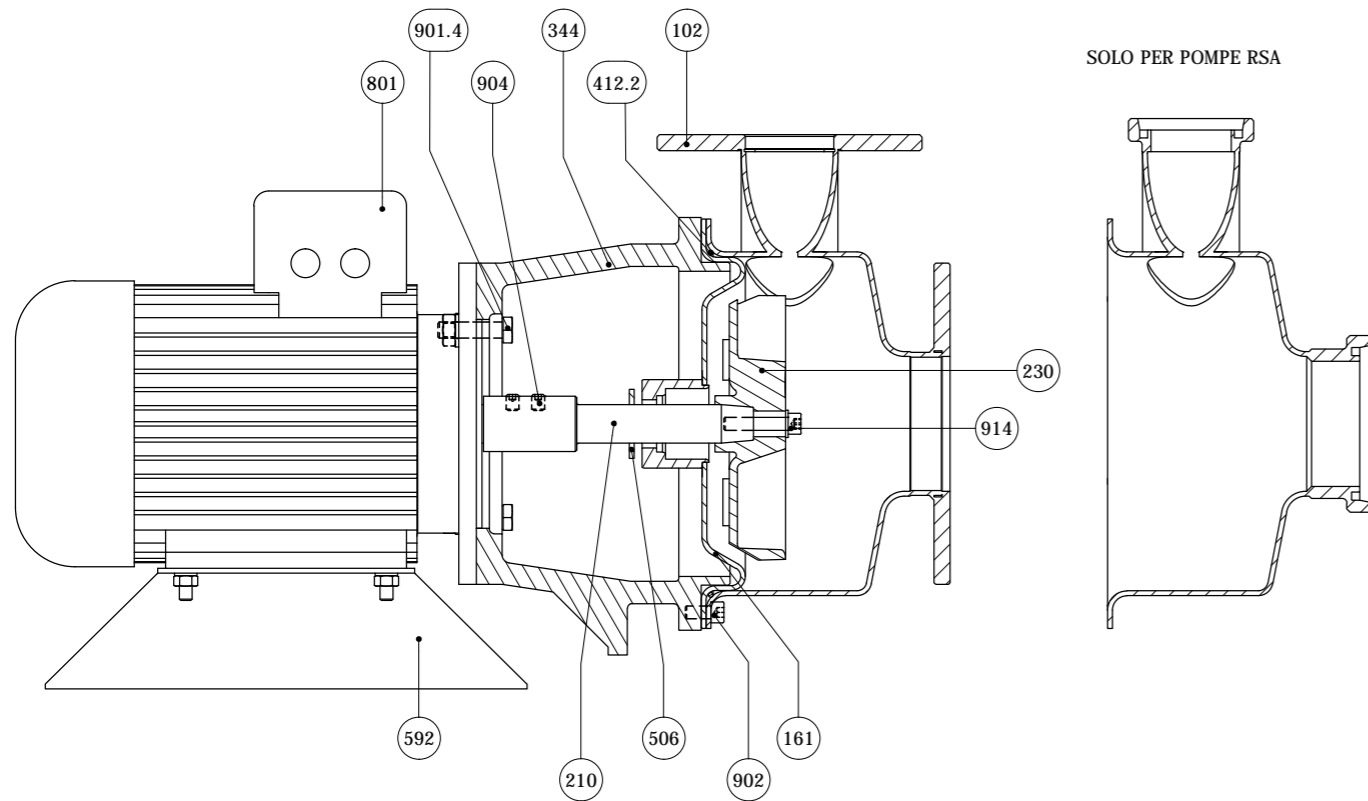

N.	Descrizione	Description
102	Corpo	Casing
161	Coperchio del corpo	Casing cover
210	Albero	Shaft
230	Girante	Impeller
344	Lanterna motore	Lantern bracket
412.2	O-ring corpo	O-ring casing
506	Anello paraspruzzi	Deflector

N.	Descrizione	Description
592	Piede motore	Electric motor foot
801	Motore elettrico	Electric motor
902	Vite T.C.E.I.	Socket head screw
904	Grano	Locking screw
914	Vite ogivale	Screw
901.4	Vite T.E.	Hex head screw

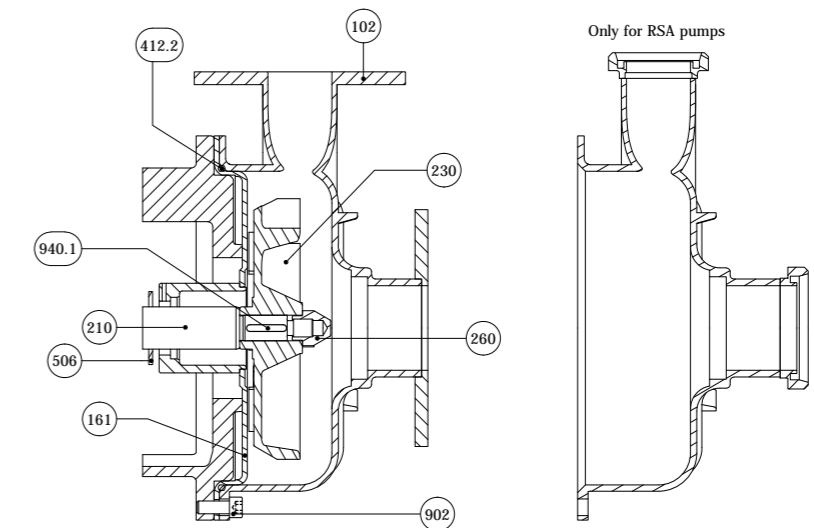
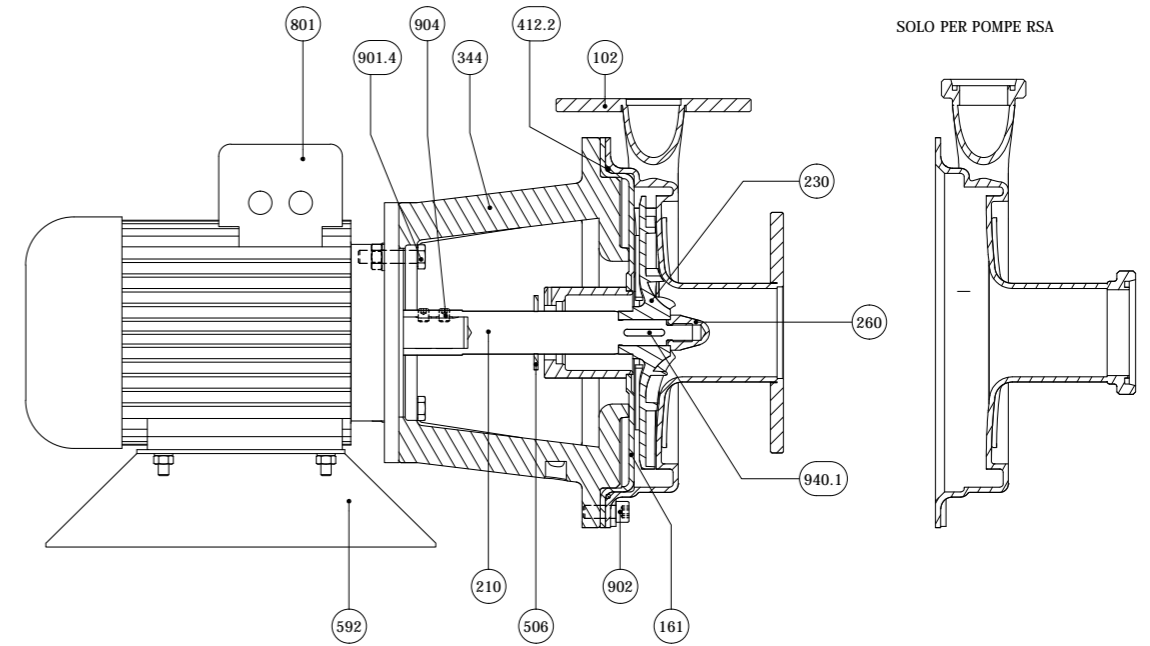

N.	Descrizione	Description
102	Corpo	Casing
161	Coperchio del corpo	Casing cover
210	Albero	Shaft
230	Girante	Impeller
260	Ogiva girante	Impeller hub
344	Lanterna motore	Lantern bracket
412.2	O-ring corpo	O-ring casing

N.	Descrizione	Description
506	Anello paraspruzzi	Deflector
592	Piede motore	Electric motor foot
801	Motore elettrico	Electric motor
902	Vite T.C.E.I.	Socket head screw
904	Grano	Locking screw
901.4	Vite T.E.	Hex head screw
940.1	Linguetta girante	Impeller key



Fig.1

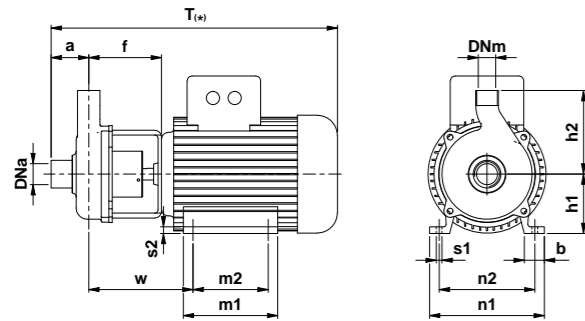

Fig.2

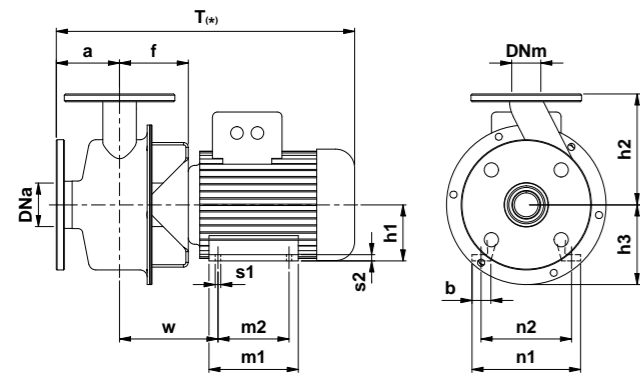

Fig.2A

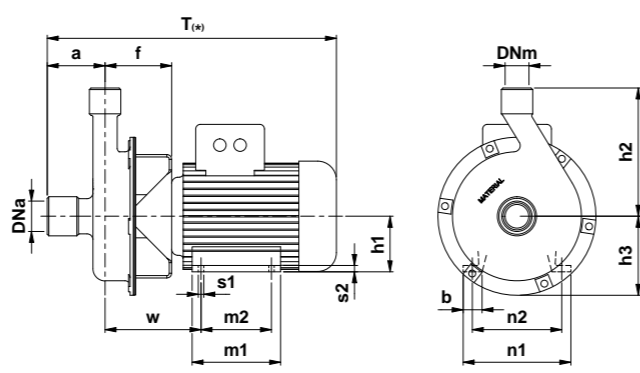

Fig.3

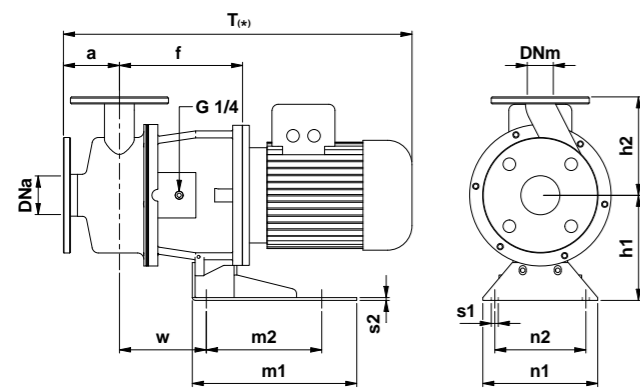

Fig.3A

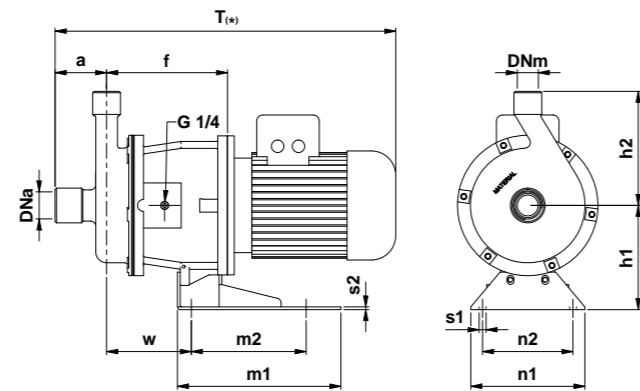

Fig.4

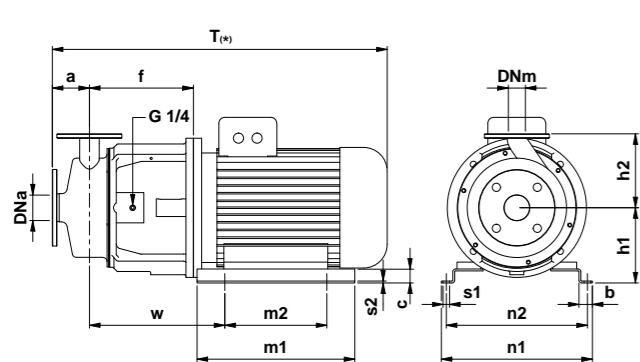
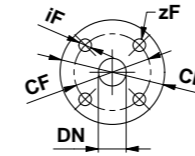
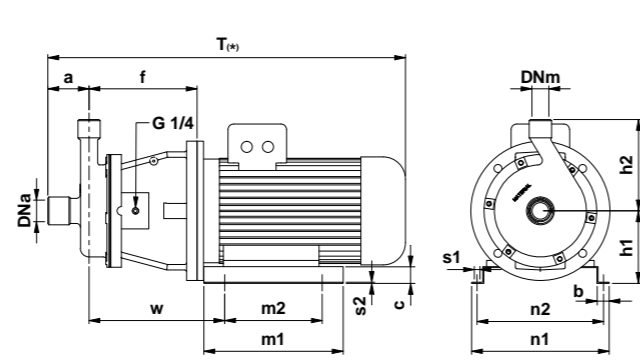

Fig.4A



Dimensioni Flange
Dimensions Flanges EN 1092-1

DNa- DNm	25	32	40	50	65	80	100	125
CF	85	100	110	125	145	160	180	210
DE	115	140	150	165	185	200	220	250
iF	14	18	18	18	18	18	18	18
zF	4	4	4	4	4	8	8	8

Accoppiamento potenza – polarità/grandezza motore
Power – polarity/motor size coupling

Poli	G/kW	G/kW	G/kW	G/kW	G/kW	G/kW	G/kW	G/kW	G/kW	G/kW	G/kW	G/kW	G/kW	G/kW	G/kW
2	71	80	80	90S	90L	100L	112M	132S	132S	132M	160M	160M	160L	180M	180M
	0,55	0,75	1,1	1,5	2,2	3	4	5,5	7,5	9,2	11	15	18,5	22	22
4	80	80	90S	90L	100L	100L	112M	132S	132M	132M	160M	160L	180M	180L	180L
	0,55	0,75	1,1	1,5	2,2	3	4	5,5	7,5	9,2	11	15	18,5	22	22
6	80	90S	90L	100L	112M	132S	132M	132M	160M	160L	180L	-	-	-	-
	0,55	0,75	1,1	1,5	2,2	3	4	5,5	7,5	11	15	-	-	-	-

Pompa tipo Pump size	Figura Picture	Grandezza motore Motor size	Dimensioni Dimensions (mm)																Peso Weight (kg) _(*)	
			Dna	Dnm	a	f	h1	h2	h3	b	c	m1	m2	n1	n2	s	s2	w		T _(*)
20-08	1	71	1" M	3/4" M	45	87	71	100	-	24	-	113	90	137,5	114,5	7	8	125	344	9
25-12	2a	71	1" 1/4 F	1" F	74	85	71	160	101	24	-	113	90	137,5	114,5	7	8	123	371	11
	3a	80	1" 1/4 F	1" F	74	174	150	164	-	-	-	235	165	164	130	10	4	122	490	21
	3a	90	1" 1/4 F	1" F	74	174	150	164	-	-	-	235	165	164	130	10	4	122	535	25
	4a	100	1" 1/4 F	1" F	74	194	130	164	-	22	30	250	175	247	227	10	2	243,5	593	36
	4a	112	1" 1/4 F	1" F	74	194	142	164	-	22	30	250	175	277	257	10	2	246,5	597	43
32-12	2	71	50	32	80	87	71	140	101	24	-	113	90	137,5	114,5	7	8	125	379	13
	3	80	50	32	80	176	150	140	-	-	-	235	165	164	130	10	4	124	498	23
	3	90	50	32	80	176	150	140	-	-	-	235	165	164	130	10	4	124	543	27
	4	100	50	32	80	196	130	140	-	22	30	250	175	247	227	10	2	245	601	38
	4	112	50	32	80	196	142	140	-	22	30	250	175	277	257	10	2	248,5	605	45
32-16	4	80	50	32	80	184	155	160	-	23	75	300	220	203	183	10	3	174	506	29
	4	90	50	32	80	184	165	160	-	23	75	300	220	218	198	10	3	192,5	551	33
	4	100	50	32	80	204	155	160	-	25	55	280	200	240	218	12	3	237	609	43
	4	112	50	32	80	204	167	160	-	25	55	280	200	270	248	12	3	244	613	50
	4	132	50	32	80	224	162	160	-	29	30	340	220	326	304	14	4	292	722	76
32-20	4	80	50	32	80	194	155	177	-	23	75	300	220	203	183	10	3	184	516	38
	4	90	50	32	80	194	165	177	-	23	75	300	220	218	198	10	3	202,5	561	42
	4	100	50	32	80	214	155	177	-	25	55	280	200	240	218	12	3	247	619	50
	4	112	50	32	80	214	167	177	-	25	55	280	200	270	248	12	3	254	623	57
	4	132	50	32	80	234	162	177	-	29	30	340	220	326	304	14	4	302	732	83

Quote e pesi possono variare senza preavviso
Dimensions and weights can change without prior notice

(*) Lunghezza e peso possono variare in funzione della marca del motore
(*) Length and weight may vary, it depends by the motor brand



Pompa tipo Pump size	Figura Picture	Grandezza motore Motor size	Dimensioni Dimensions (mm)																Peso Weight (kg) ^(*)		
			Dna	Dnm	a	f	h1	h2	h3	b	c	m1	m2	n1	n2	s	s2	w		T _(*)	
40-12	2	71	65	40	80	90	71	140	101	24	-	113	90	137,5	114,5	7	8	126	382	13	
	3	80	65	40	80	177	150	140	-	-	-	235	165	164	130	10	4	125	499	24	
	3	90	65	40	80	177	150	140	-	-	-	235	165	164	130	10	4	125	544	28	
	4	100	65	40	80	197	130	140	-	22	30	250	175	247	227	10	2	246	602	39	
	4	112	65	40	80	197	142	140	-	22	30	250	175	277	257	10	2	250	606	46	
	4	132	65	40	80	217	162	140	-	29	30	340	220	326	304	14	4	285	715	62	
40-16	4	80	65	40	80	190	155	160	-	23	75	300	220	203	183	10	3	180	512	29	
	4	90	65	40	80	190	165	160	-	23	75	300	220	218	198	10	3	198,5	557	33	
	4	100	65	40	80	210	155	160	-	25	55	280	200	240	218	12	3	243	615	43	
	4	112	65	40	80	210	167	160	-	25	55	280	200	270	248	12	3	250	619	50	
	4	132	65	40	80	230	162	160	-	29	30	340	220	326	304	14	4	298	728	76	
	40-20	4	90	65	40	100	196	165	180	-	23	75	300	220	218	198	10	3	204,5	583	41
4		100	65	40	100	216	155	180	-	25	55	280	200	240	218	12	3	249	641	50	
4		112	65	40	100	216	167	180	-	25	55	280	200	270	248	12	3	256	645	57	
4		132	65	40	100	236	162	180	-	29	30	340	220	326	304	14	4	304	754	82	
50-16		4	80	80	50	100	195	155	180	-	23	75	300	220	203	183	10	3	185	537	30
		4	90	80	50	100	195	165	180	-	23	75	300	220	218	198	10	3	203,5	582	34
	4	100	80	50	100	215	155	180	-	25	55	280	200	240	218	12	3	248	640	44	
	4	112	80	50	100	215	167	180	-	25	55	280	200	270	248	12	3	255	644	51	
	4	132	80	50	100	235	162	180	-	29	30	340	220	326	304	14	4	303	753	77	
	50-20	4	90	65	50	100	222	165	200	-	23	75	300	220	218	198	10	3	330,5	609	43
4		100	65	50	100	242	155	200	-	25	55	280	200	240	218	12	3	275	667	52	
4		112	65	50	100	242	167	200	-	25	55	280	200	270	248	12	3	282	671	59	
4		132	65	50	100	262	162	200	-	29	30	340	220	326	304	14	4	330	780	84	
65-16		4	90	100	65	100	196	165	200	-	23	75	300	220	218	198	10	3	204,5	583	35
		4	100	100	65	100	216	155	200	-	25	55	280	200	240	218	12	3	249	641	45
	4	112	100	65	100	216	167	200	-	25	55	280	200	270	248	12	3	256	645	52	
65-20	4	100	80	65	99,5	250,5	155	225	-	25	55	280	200	240	218	12	3	283,5	675	53	
	4	112	80	65	99,5	250,5	167	225	-	25	55	280	200	270	248	12	3	290,5	679	60	
	4	132	80	65	99,5	270,5	162	225	-	29	30	340	220	326	304	14	4	338,5	788	85	

Quote e pesi possono variare senza preavviso
Dimensions and weights can change without prior notice

(*) Lunghezza e peso possono variare in funzione della marca del motore
(* Length and weight may vary, it depends by the motor brand



Fig.1

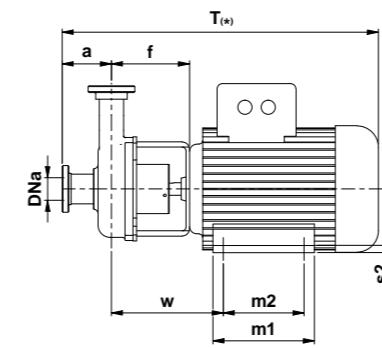

Fig.2

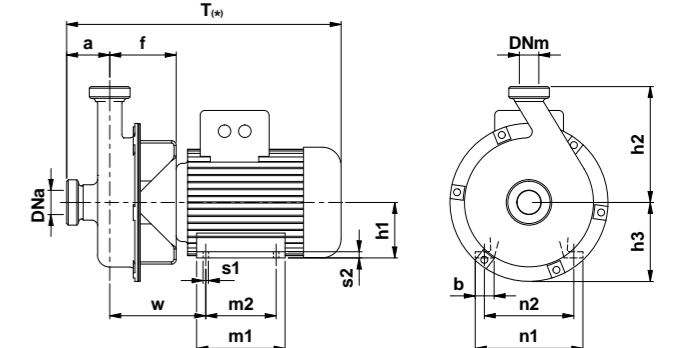

Fig.3

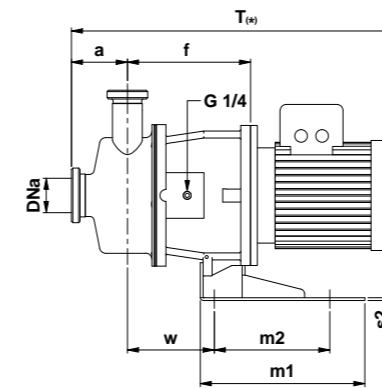
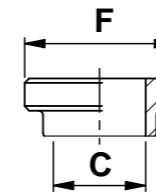
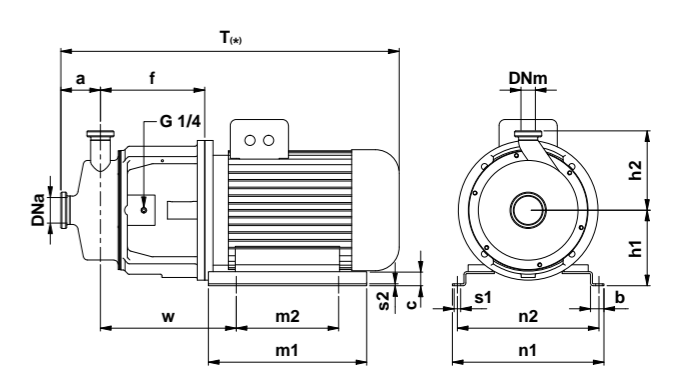

Fig.4



DIN 11851		
DNa-DNm	C	F
25	25	52x1/6
32	31	58x1/6
40	37	65x1/6
50	49	78x1/6
65	66	95x1/6
80	81	110x1/4
100	98	130x1/4

Accoppiamento potenza – polarità/grandezza motore
Power – polarity/motor size coupling

Poli	G/kW	G/kW	G/kW	G/kW	G/kW	G/kW	G/kW	G/kW	G/kW	G/kW	G/kW	G/kW	G/kW	G/kW
2	71	80	80	90S	90L	100L	112M	132S	132S	132M	160M	160M	160L	180M
	0,55	0,75	1,1	1,5	2,2	3	4	5,5	7,5	9,2	11	15	18,5	22
4	80	80	90S	90L	100L	100L	112M	132S	132M	132M	160M	160L	180M	180L
	0,55	0,75	1,1	1,5	2,2	3	4	5,5	7,5	9,2	11	15	18,5	22
6	80	90S	90L	100L	112M	132S	132M	132M	160M	160L	180L	-	-	-
	0,55	0,75	1,1	1,5	2,2	3	4	5,5	7,5	11	15	-	-	-

Ingombri monoblocco
Close coupled pump overall dimensions



Girante vortex
Vortex impeller

Pompa tipo Pump size	Figura Picture	Grandezza motore Motor size	Dimensioni Dimensions (mm)																	Peso Weight (kg) _(*)
			Dna	Dnm	a	f	h1	h2	h3	b	c	m1	m2	n1	n2	s	s2	w	T _(*)	
20-08	1	71	25	25	55	87	71	115	-	24	-	113	90	137,5	114,5	7	8	125	354	9
"25-12 GAS (std)"	2	71	32	25	55	85	71	148	101	24	-	113	90	137,5	114,5	7	8	123	352	11
	3	80	32	25	55	174	150	148	-	-	-	235	165	164	130	10	4	122	471	21
	3	90	32	25	55	174	150	148	-	-	-	235	165	164	130	10	4	122	516	25
	4	100	32	25	55	194	130	148	-	22	30	250	175	247	227	10	2	243,5	574	36
32-12	4	112	32	25	55	194	142	148	-	22	30	250	175	277	257	10	2	246,5	578	43
	2	71	50	32	80	87	71	150	101	24	-	113	90	137,5	114,5	7	8	125	379	11
	3	80	50	32	80	176	150	150	-	-	-	235	165	164	130	10	4	124	498	21
	3	90	50	32	80	176	150	150	-	-	-	235	165	164	130	10	4	124	543	25
	4	100	50	32	80	196	130	150	-	22	30	250	175	247	227	10	2	245	601	36
32-16	4	112	50	32	80	196	142	150	-	22	30	250	175	277	257	10	2	248,5	605	43
	4	132	50	32	80	216	162	150	-	29	30	340	220	326	304	14	4	284	714	60
	4	80	50	32	85	184	155	170	-	23	75	300	220	203	183	10	3	174	511	27
	4	90	50	32	85	184	165	170	-	23	75	300	220	218	198	10	3	192,5	556	31
	4	100	50	32	85	204	155	170	-	25	55	280	200	240	218	12	3	237	614	41
32-20	4	112	50	32	85	204	167	170	-	25	55	280	200	270	248	12	3	244	618	48
	4	132	50	32	85	224	162	170	-	29	30	340	220	326	304	14	4	292	727	74
	4	80	50	32	95	194	155	192,5	-	23	75	300	220	203	183	10	3	184	531	36
	4	90	50	32	95	194	165	192,5	-	23	75	300	220	218	198	10	3	202,5	576	40
40-12	4	100	50	32	95	214	155	192,5	-	25	55	280	200	240	218	12	3	247	634	49
	4	112	50	32	95	214	167	192,5	-	25	55	280	200	270	248	12	3	254	638	56
	4	132	50	32	95	234	162	192,5	-	29	30	340	220	326	304	14	4	302	747	81
	2	71	65	40	73	90	71	150	101	24	-	113	90	137,5	114,5	7	8	126	375	11
40-16	3	80	65	40	73	177	150	150	-	-	-	235	165	164	130	10	4	125	492	22
	3	90	65	40	73	177	150	150	-	-	-	235	165	164	130	10	4	125	537	26
	4	100	65	40	73	197	130	150	-	22	30	250	175	247	227	10	2	246	595	36
	4	112	65	40	73	197	142	150	-	22	30	250	175	277	257	10	2	250	599	43
40-20	4	132	65	40	73	217	162	150	-	29	30	340	220	326	304	14	4	285	708	60
	4	80	65	40	73	190	155	170	-	23	75	300	220	203	183	10	3	180	505	27
	4	90	65	40	73	190	165	170	-	23	75	300	220	218	198	10	3	198,5	550	31
	4	100	65	40	73	210	155	170	-	25	55	280	200	240	218	12	3	243	608	41
50-16	4	112	65	40	73	210	167	170	-	25	55	280	200	270	248	12	3	250	612	48
	4	132	65	40	73	230	162	170	-	29	30	340	220	326	304	14	4	298	721	74
	4	90	65	40	117	196	165	195	-	23	75	300	220	218	198	10	3	204,5	600	39
	4	100	65	40	117	216	155	195	-	25	55	280	200	240	218	12	3	249	658	48
50-20	4	112	65	40	117	216	167	195	-	25	55	280	200	270	248	12	3	256	662	55
	4	132	65	40	117	236	162	195	-	29	30	340	220	326	304	14	4	304	771	80
	4	80	80	50	113	195	155	190	-	23	75	300	220	203	183	10	3	185	550	28
	4	90	80	50	113	195	165	190	-	23	75	300	220	218	198	10	3	203,5	595	32
65-16	4	100	80	50	113	215	155	190	-	25	55	280	200	240	218	12	3	248	653	42
	4	112	80	50	113	215	167	190	-	25	55	280	200	270	248	12	3	255	657	49
	4	132	80	50	113	235	162	190	-	29	30	340	220	326	304	14	4	303	766	75
	4	90	65	65	117	222	165	215	-	23	75	300	220	218	198	10	3	330,5	626	43
65-20	4	100	65	65	117	242	155	215	-	25	55	280	200	240	218	12	3	275	684	49
	4	112	65	50	117	242	167	215	-	25	55	280	200	270	248	12	3	282	688	56
	4	132	65	50	117	262	162	215	-	29	30	340	220	326	304	14	4	330	797	81
	4	90	100	65	112	196	165	212	-	23	75	300	220	218	198	10	3	204,5	595	33
65-20	4	100	100	65	112	216	155	212	-	25	55	280	220	240	218	12	3	249	653	42
	4	112	100	65	112	216	167	212	-	25	55	280	200	270	248	12	3	256	657	49
	4	132	80	65	133	250,5	155	240	-	25	55	280	200	240	218	12	3	283,5	708,5	50
65-20	4	112	80	65	133	250,5	167	240	-	25	55	280	200	270	248	12	3	290,5	712,5	57
	4	132	80	65	133	270,5	162	240	-	29	30	340	220	326	304	14	4	338,5	821,5	82

Quote e pesi possono variare senza preavviso
Dimensions and weights can change without prior notice

(*) Lunghezza e peso possono variare in funzione della marca del motore
(*) Length and weight may vary, it depends by the motor brand

Campo di applicazione
Coverage chart

Girante vortex
Vortex impeller

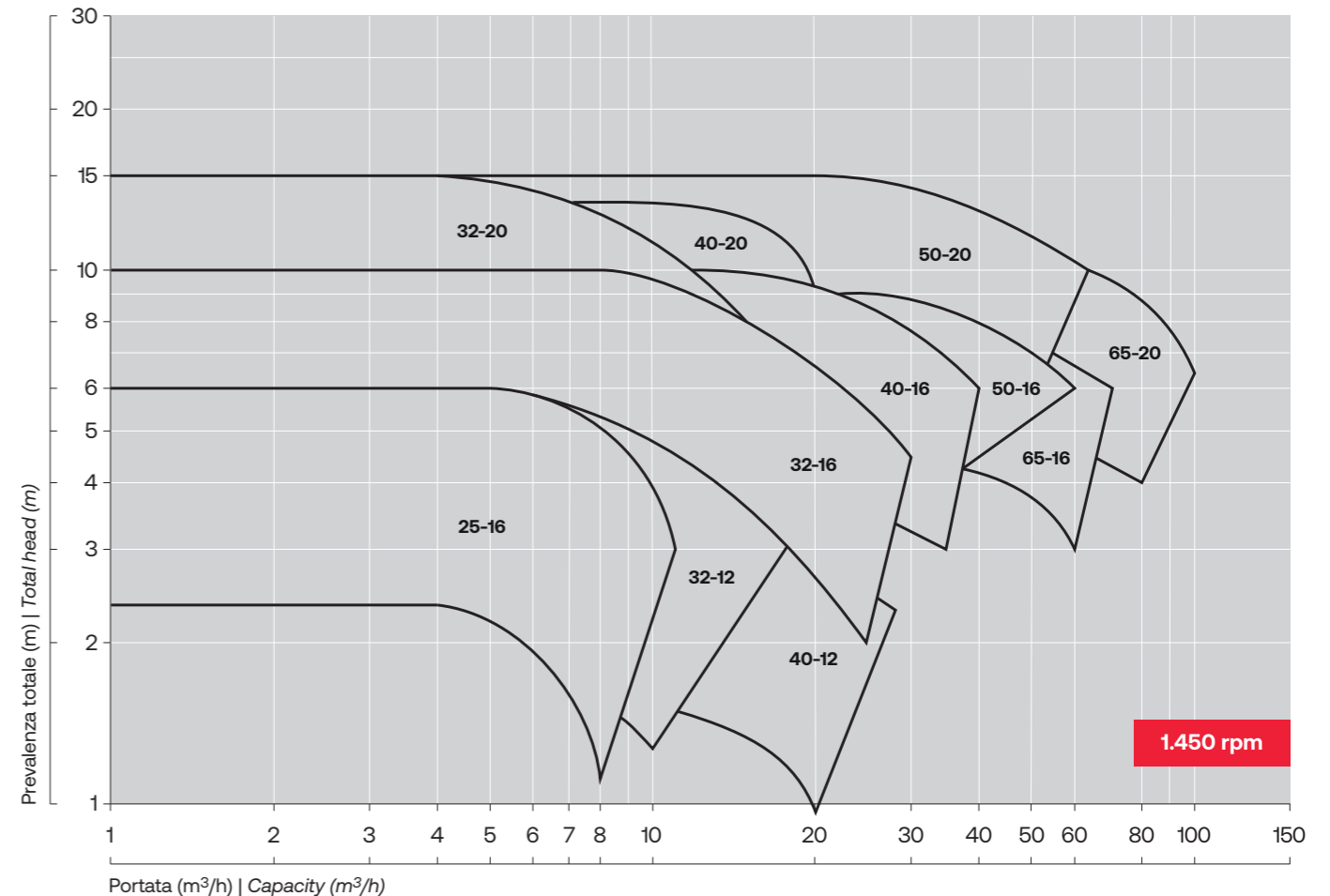
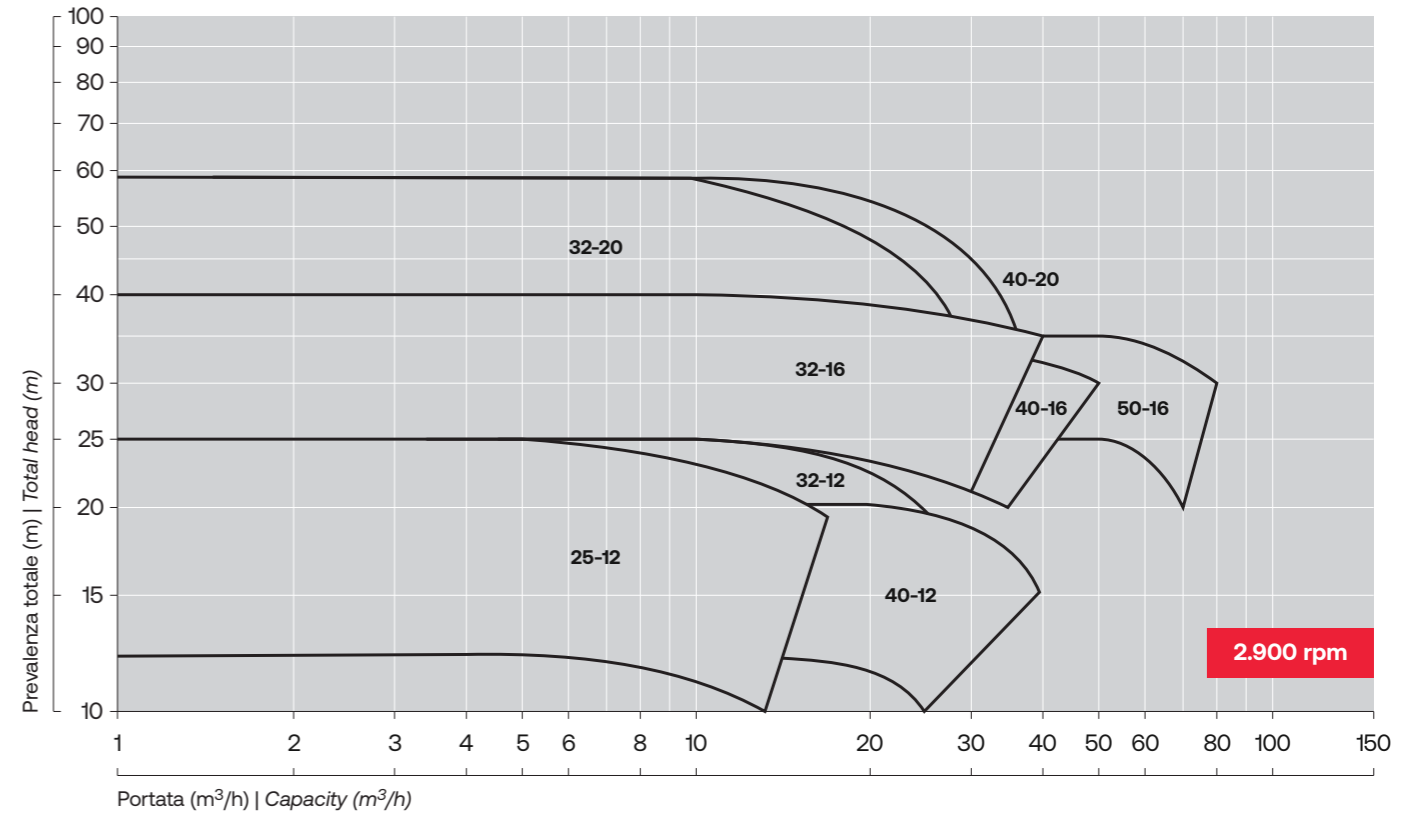

Quote e pesi possono variare senza preavviso
Dimensions and weights can change without prior notice

(*) Lunghezza e peso possono variare in funzione della marca del motore
(*) Length and weight may vary, it depends by the motor brand

Curve prestazionali
Performance curves

Curve prestazionali redatte secondo classe di accettabilità ISO 9906 - Classe 2B.

I valori di NPSH mostrati si riferiscono ad una caduta di prevalenza totale pari al 3%.
Per portate inferiori a $Q=0,3 \times Q_{opt}$ non è possibile fornire valori attendibili di NPSH.
I valori di prevalenza, potenza, NPSH e rendimento si riferiscono a liquidi con densità relativa pari a 1,0 ed una viscosità cinematica massima di 20 mm²/s.
In caso di densità relativa (ρ_r) diversa da 1.0 sarà necessario moltiplicare il valore della potenza per "ro" e dividere di conseguenza il rendimento per "ro".

Se la viscosità supera i 20 mm²/s, dovranno essere valutati gli effetti della viscosità sui parametri prestazionali della pompa e considerare i relativi dati con acqua fredda.
Le curve prestazionali si riferiscono a pompe ad asse orizzontale in esecuzione Asse Nudo e tenuta meccanica singola; per configurazioni diverse (cuscinetti maggiorati, tenute meccaniche doppie, pompe ad asse verticale, ecc..) il rendimento della pompa potrebbe differire da quello indicato a catalogo.

Performance curves according to ISO 9906 - Grade 2B acceptability class.

The given NPSH values correspond to a total head drop of 3%. For flow rates below $Q = 0.3 \times Q_{opt}$, no reliable NPSH values can be provided.
Head, power, NPSH and efficiency values refer to liquids with a relative density of 1.0 and a maximum kinematic viscosity of 20 mm²/s.
In case of a different relative density (ρ_r) than 1.0, it will be necessary to multiply the power value by "ro" and, accordingly, divide the efficiency by "ro".

If the viscosity exceeds 20 mm²/s, the effects of viscosity on the pump's performance parameters must be evaluated, considering the related data with cold water.
The performance curves refer to horizontal pumps with bare shaft execution and single mechanical seal.
For different configurations (oversized bearings, double mechanical seals, vertical-axis pumps, etc.), the pump's efficiency may differ from the one indicated in the catalogue.

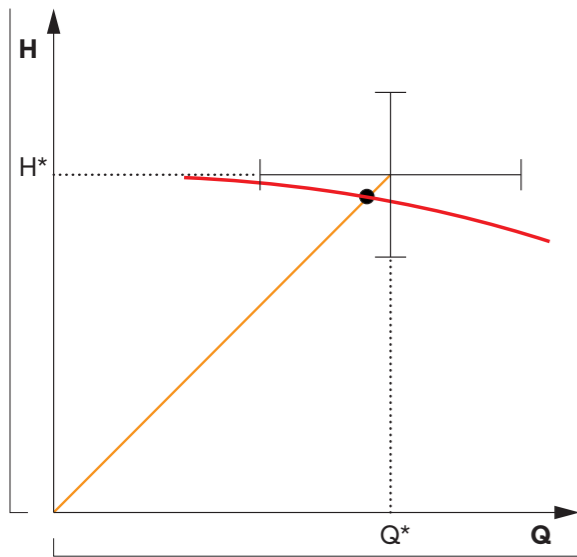

ISO 9906 Classe 2B Grade 2B	ΔQ	±8%
	ΔH	±5%

Campi di applicazione
Coverage chart

Girante vortex
Vortex impeller

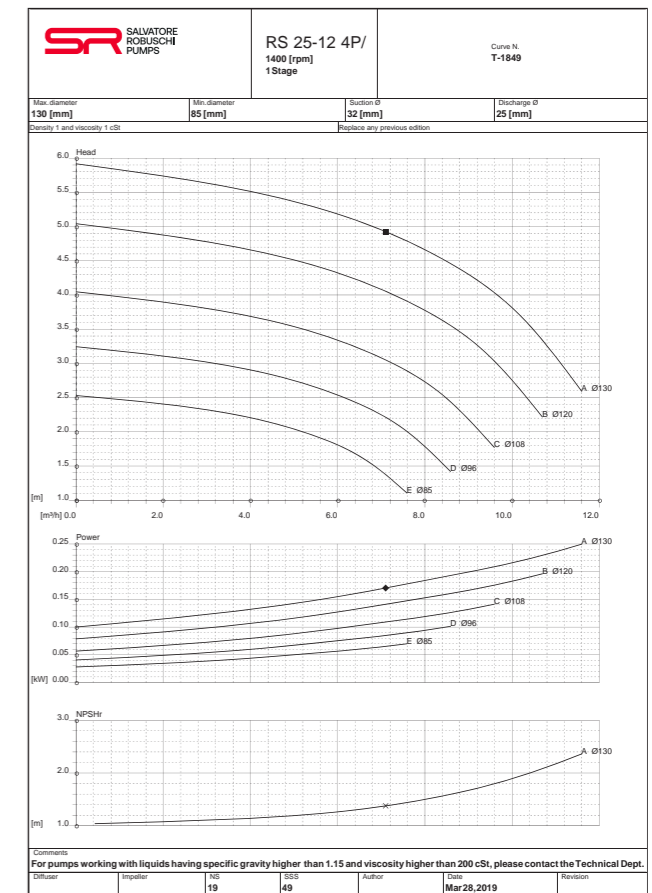
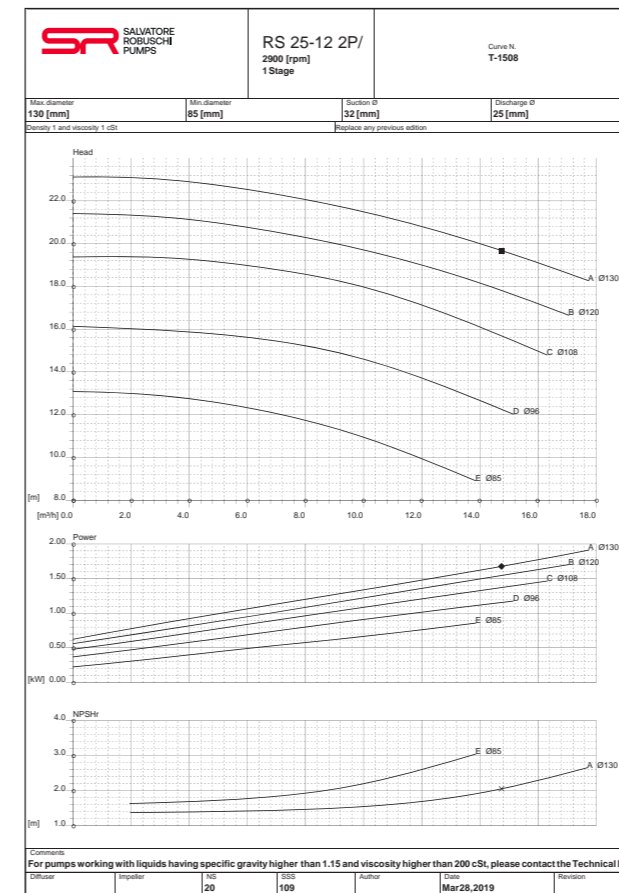
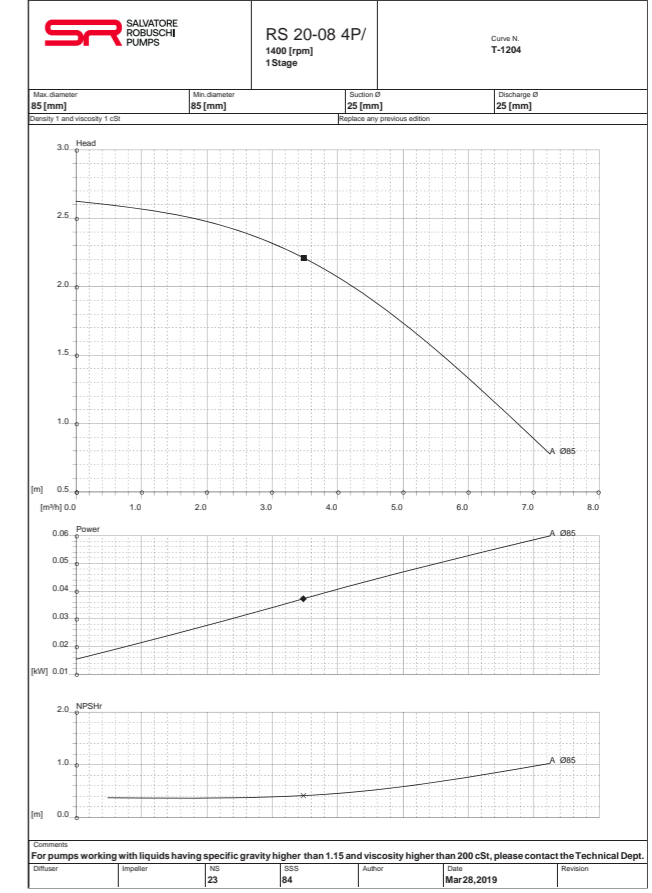
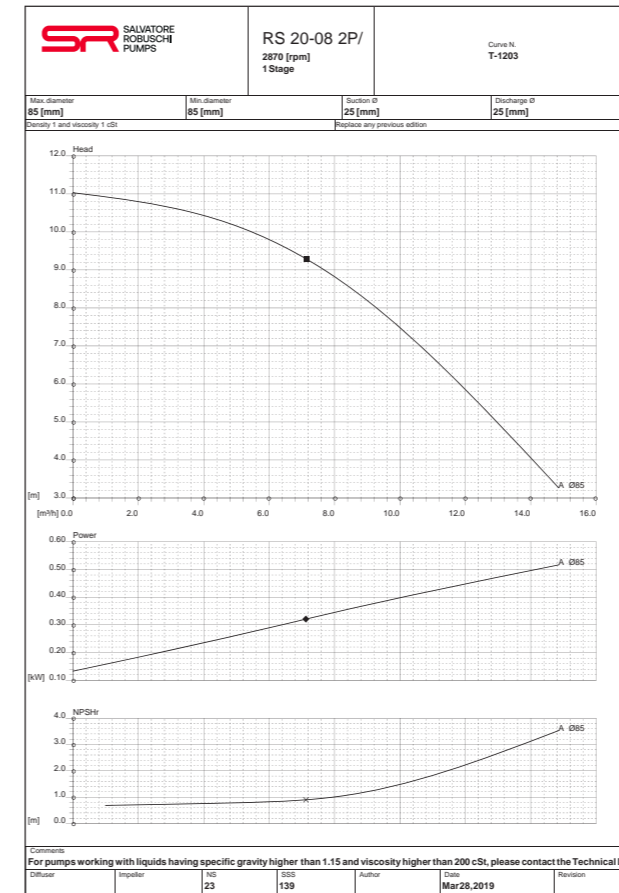

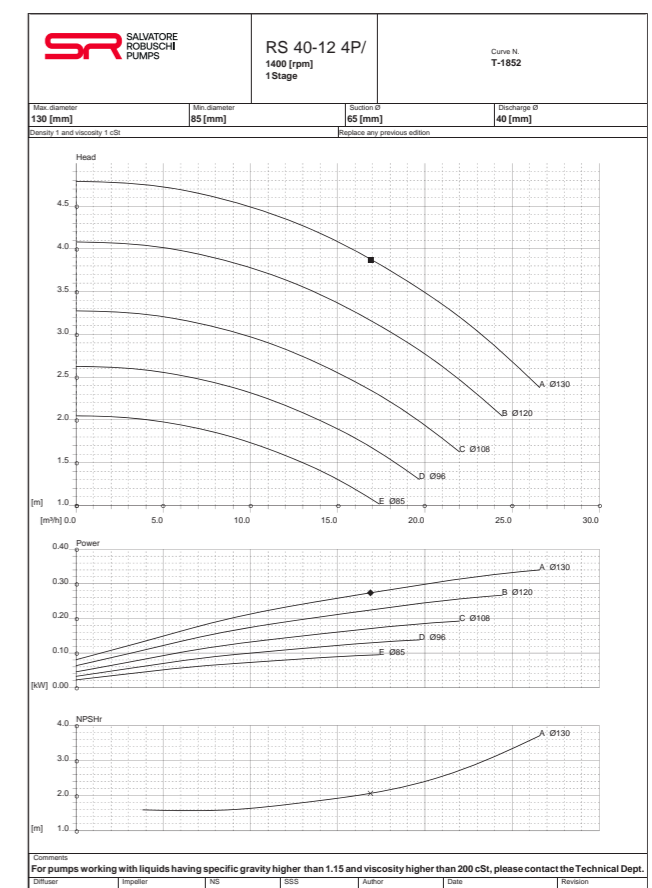
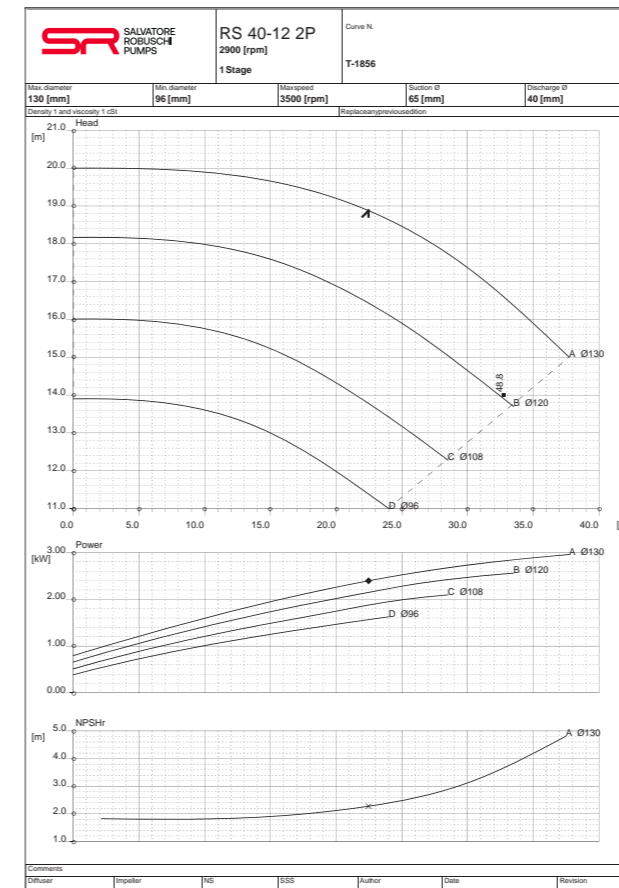
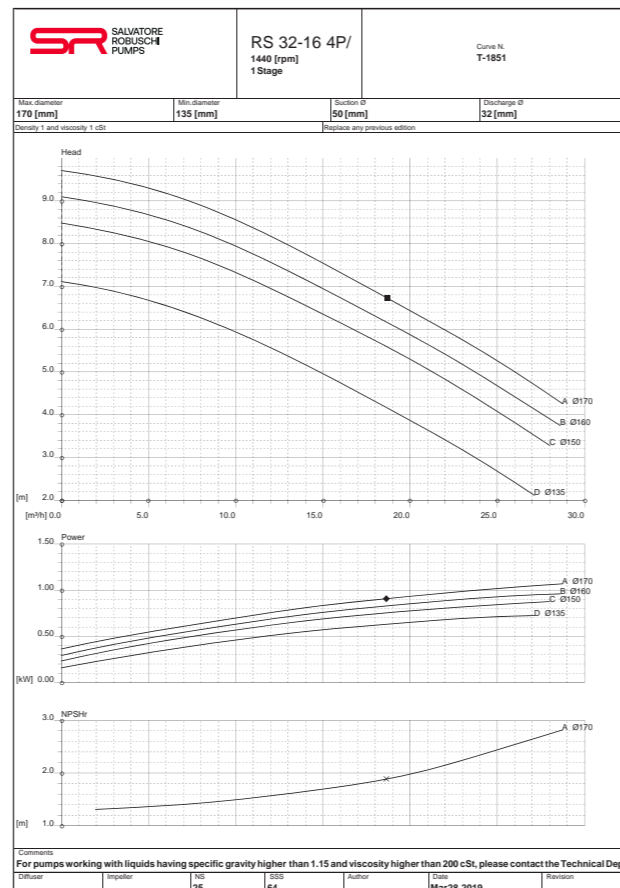
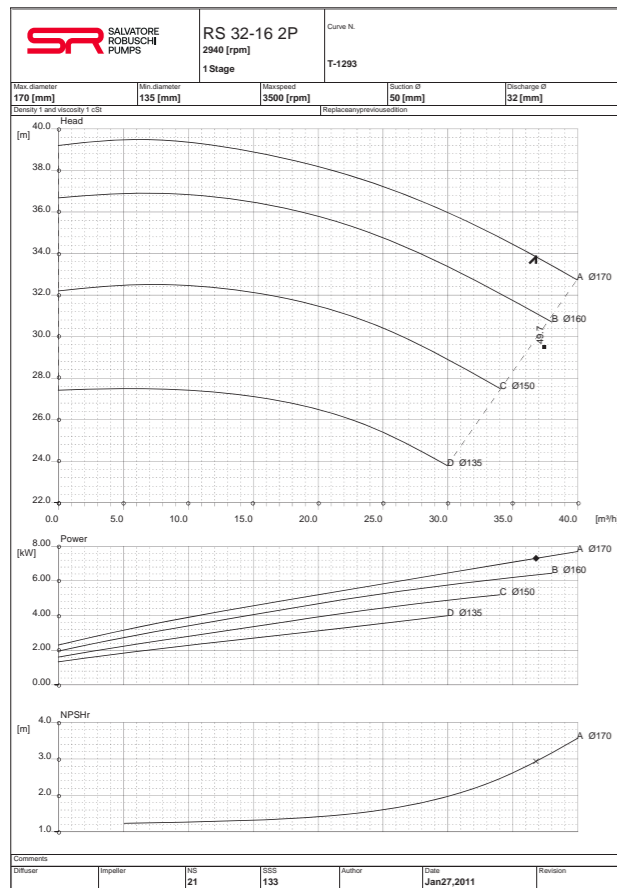
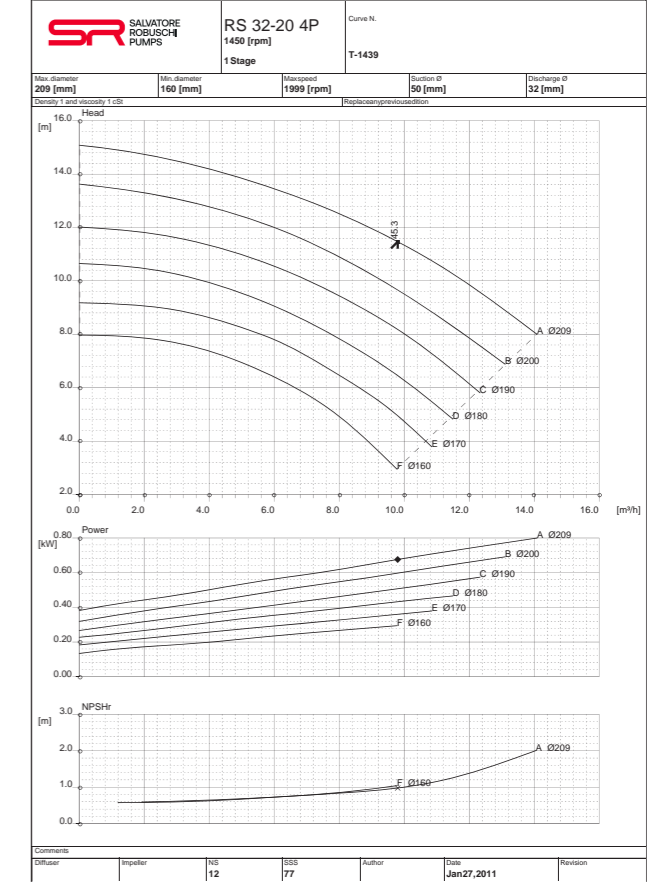
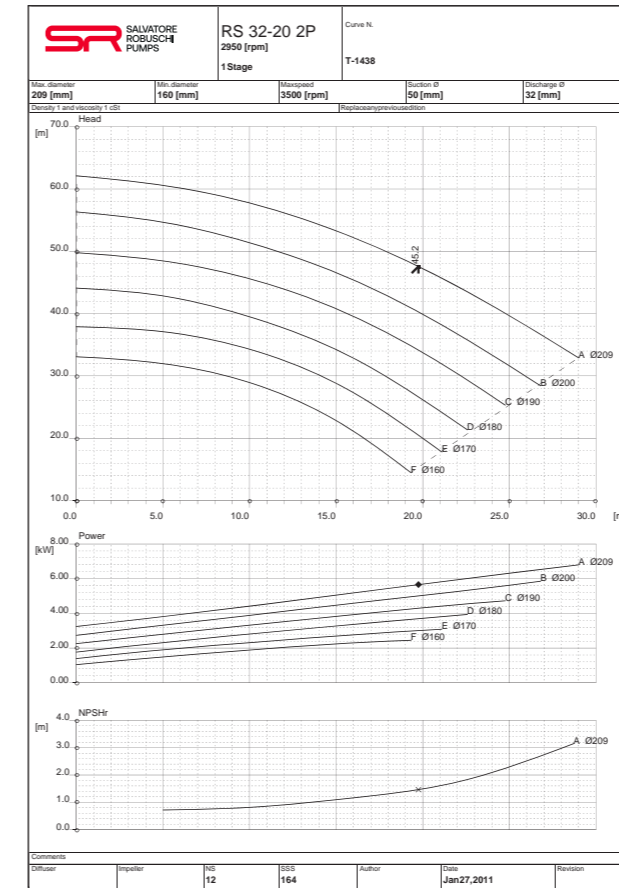
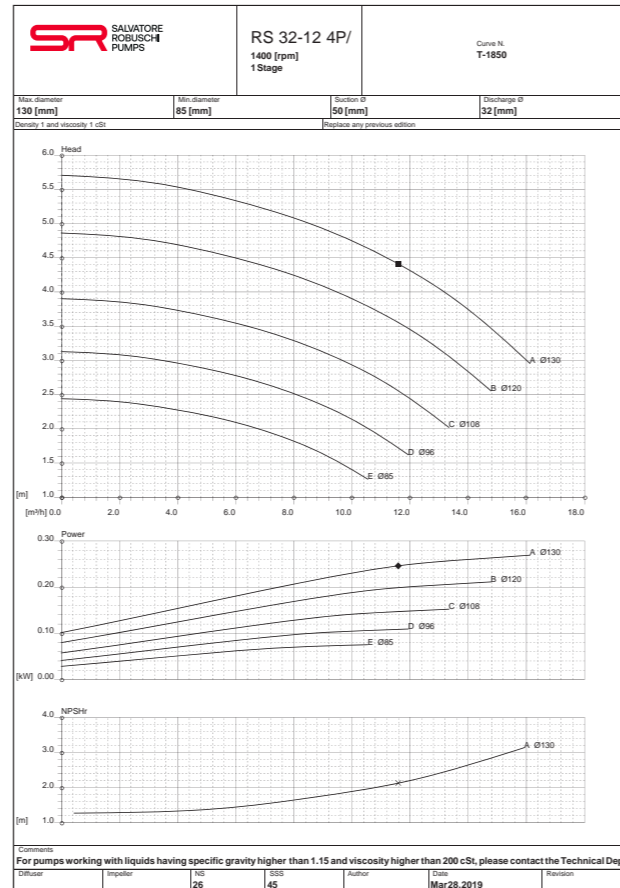
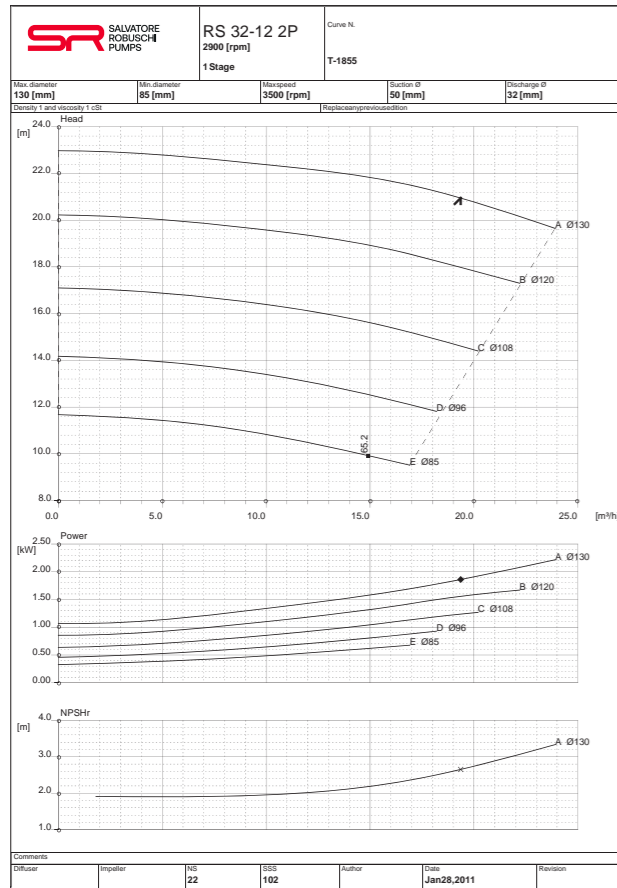

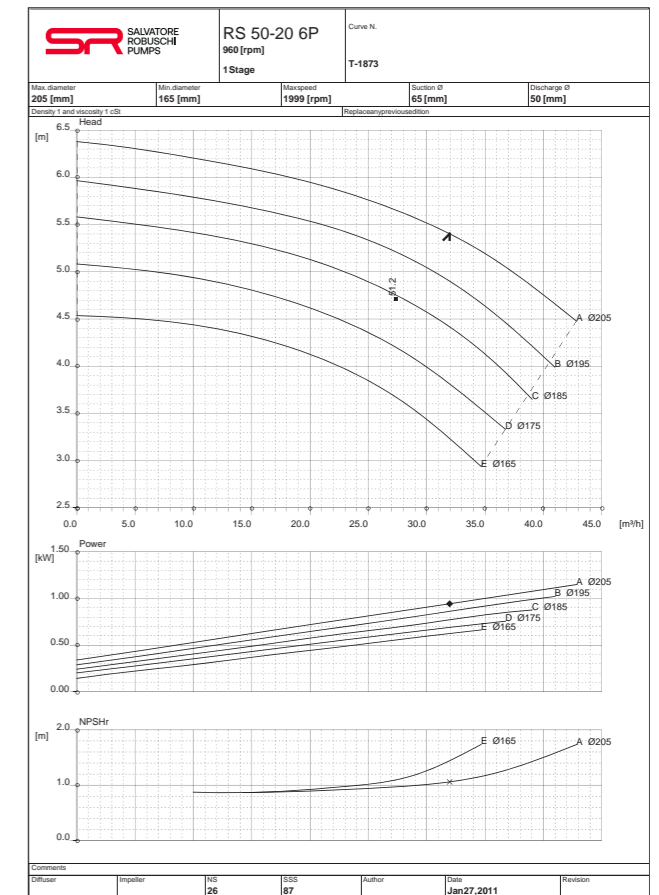
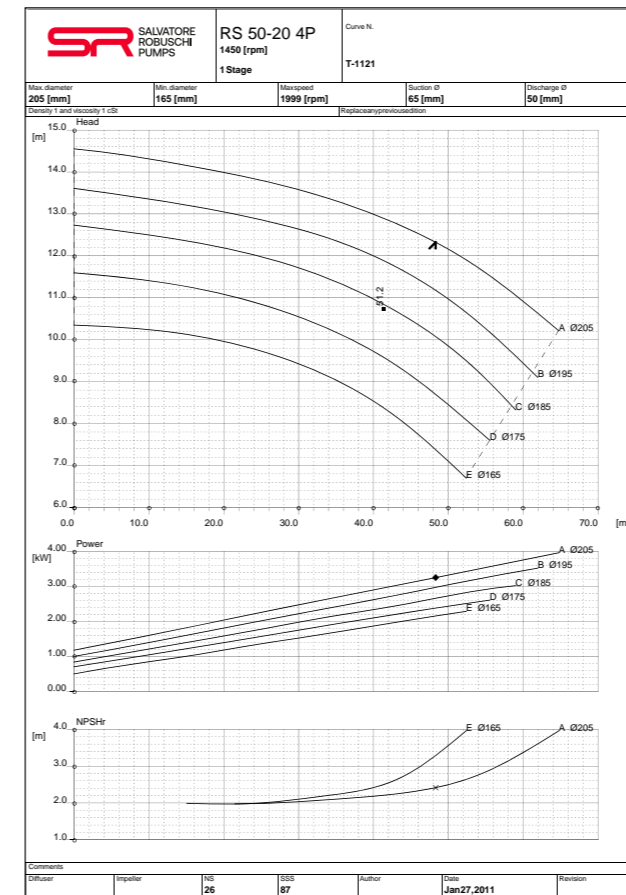
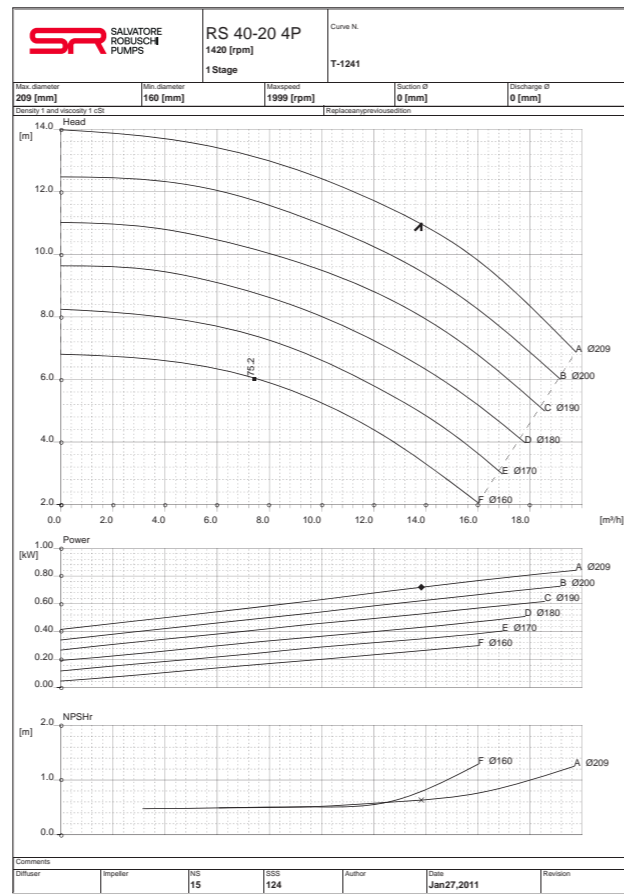
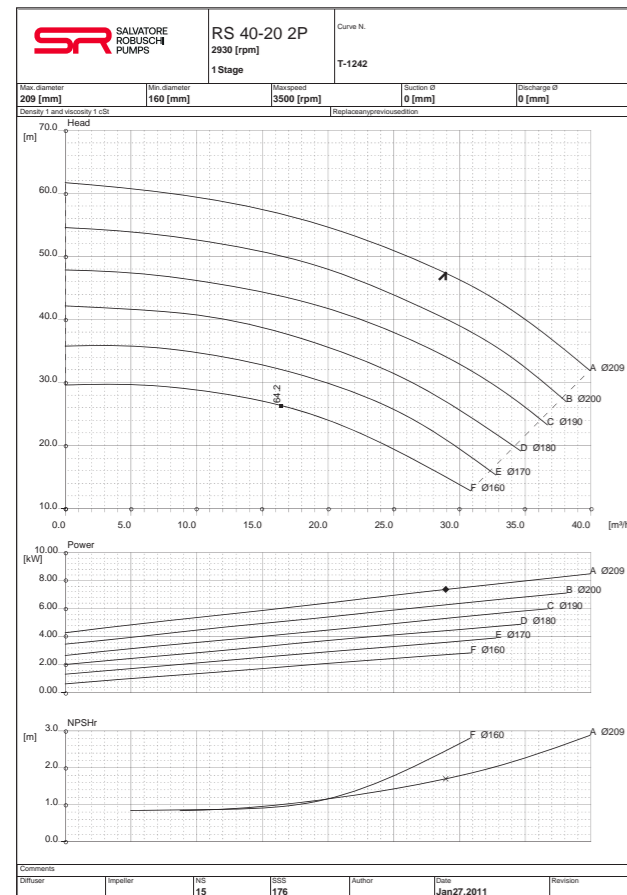
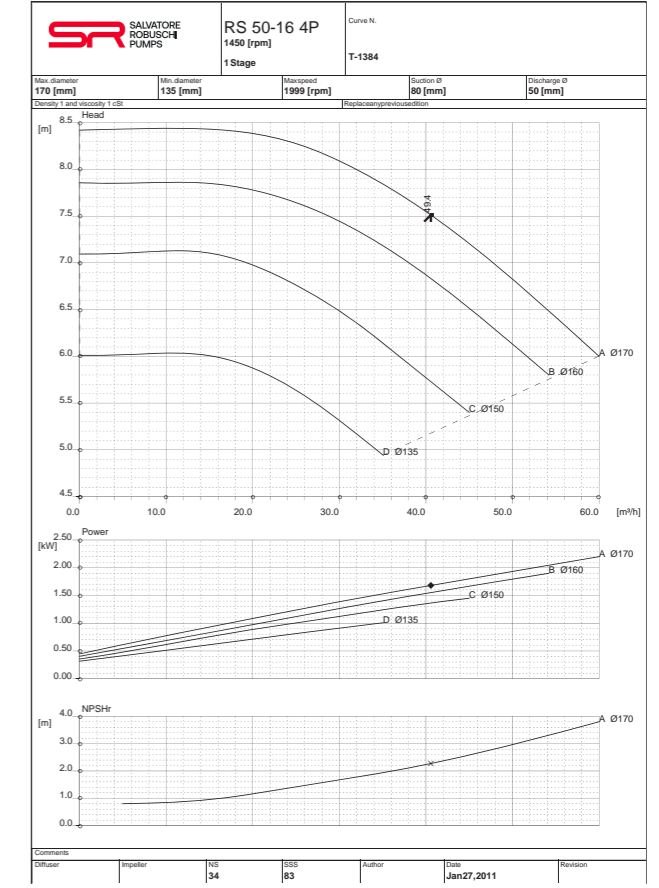
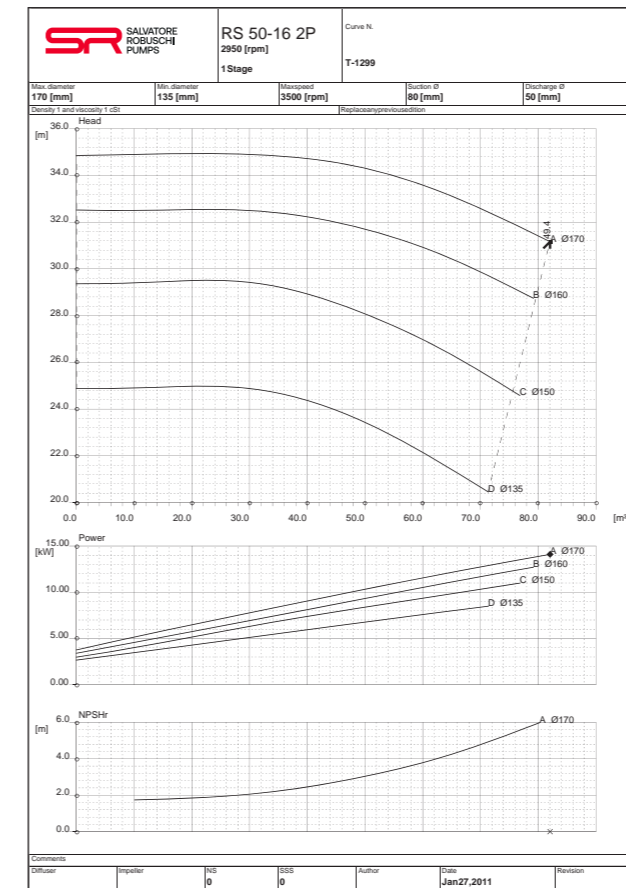
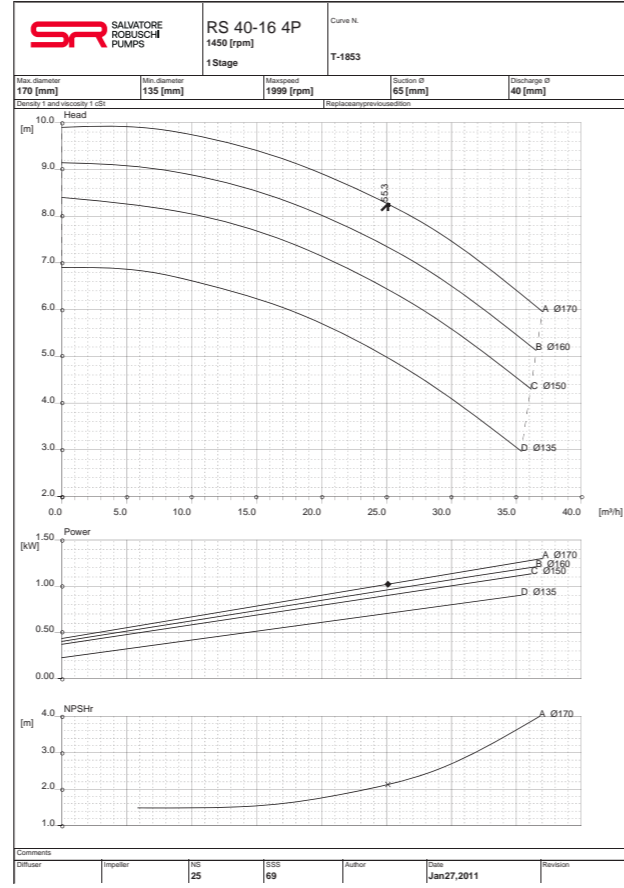
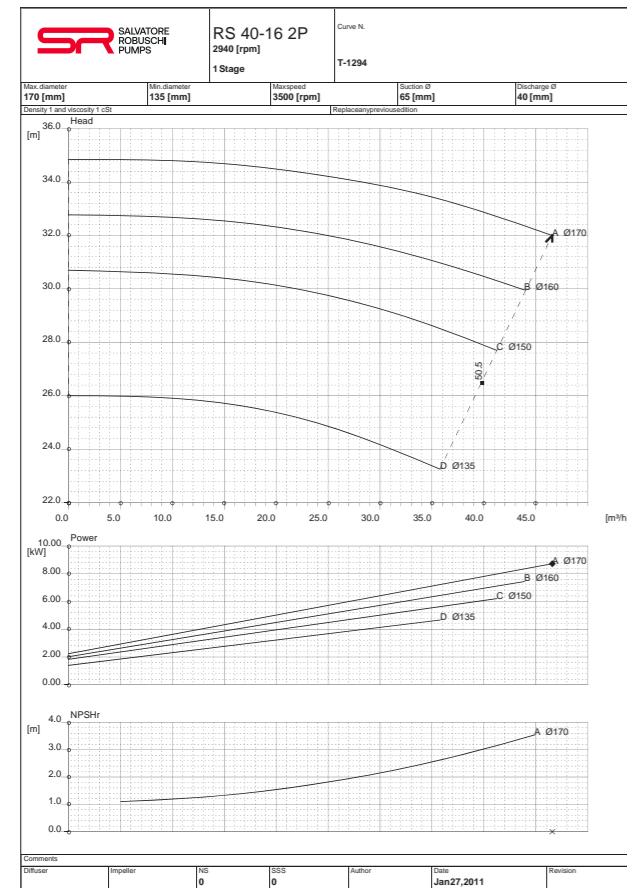

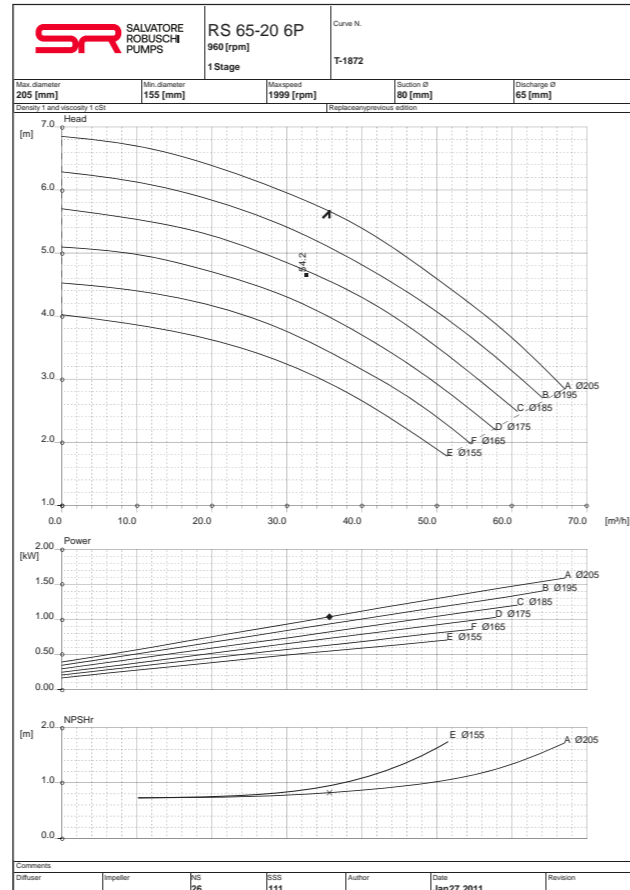
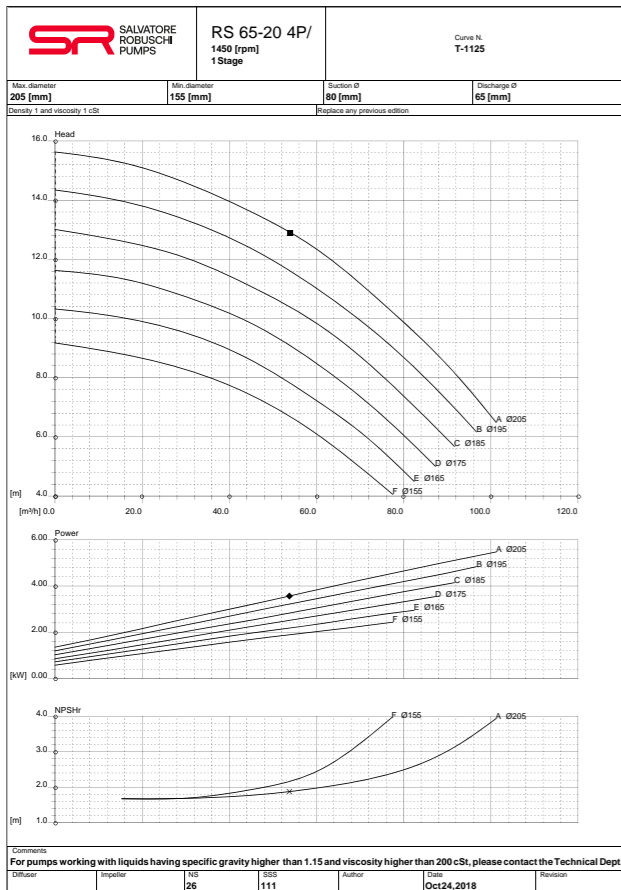
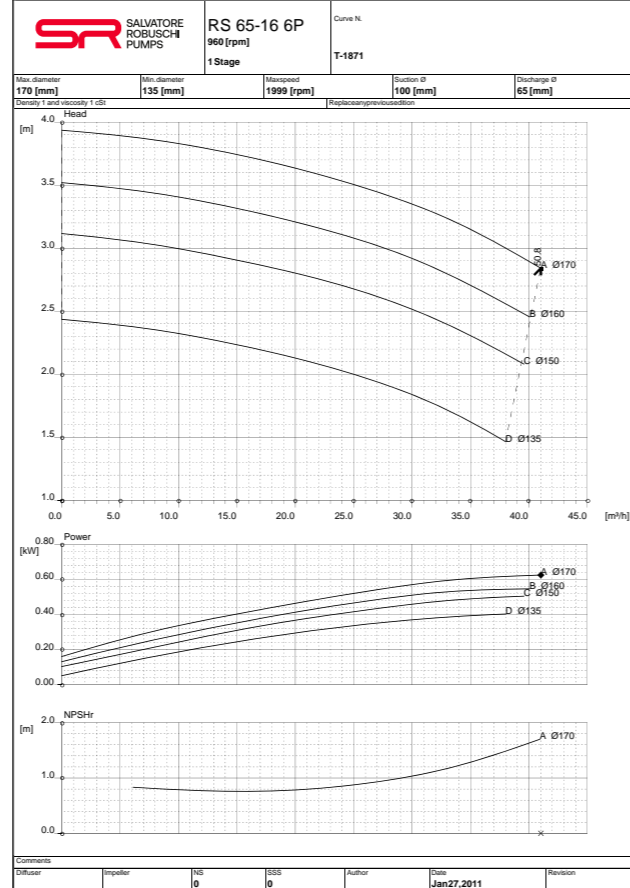
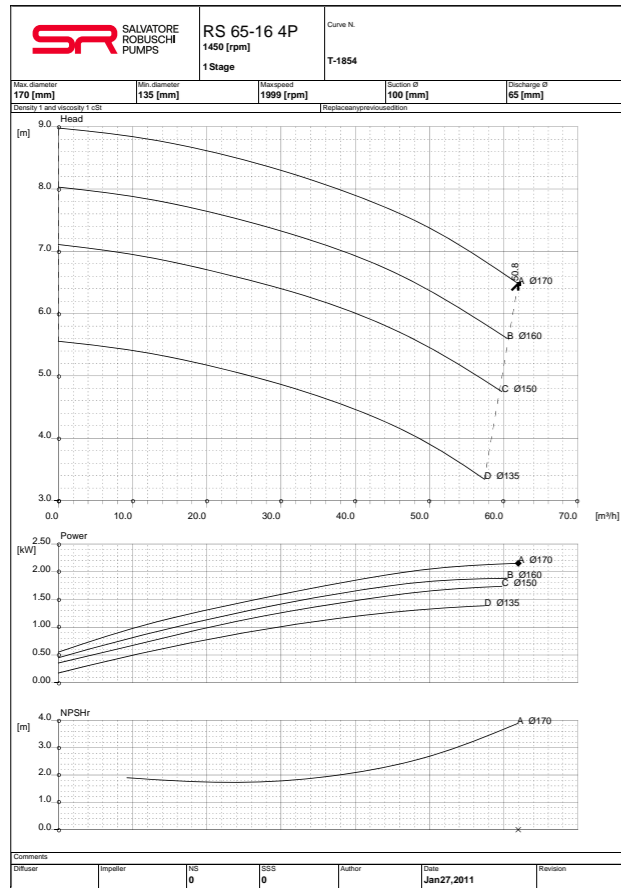

N° parte Part No.	Descrizione Description	Numero di pompe Number of pumps									
		1	2	3	4	5	da 6 a 7 from 6 to 7	da 8 a 9 from 8 to 9	Da 10 e oltre 10 and above		
210	Albero Shaft	1	1	1	1	2	2	2	20%		
230	Girante Impeller	1	1	1	1	2	2	2	20%		
135	Piastra usura Wear plate	1	1	2	2	2	2	2	20%		
506	Anello paraspruzzi Deflector	1	1	1	1	2	2	2	20%		
400.1	Guarnizioni idrauliche Hydraulic gaskets (Set)	2	4	4	5	6	8	8	80%		
400.4											
400.5											
400.6											
400.7											
412.3											
Per pompe con tenute meccaniche For pumps with mechanical seals											
433.1	Tenuta meccanica completa (Set) Complete Mechanical Seal (Set)	1	2	2	2	3	3	4	40%		
433.2											
Per pompe con baderne For pumps with packings glands											
461	Baderne (Set) Packing glands (Set)	2	4	4	6	6	6	8	100%		

N° parte Part No.	Descrizione Description	Numero di pompe Number of pumps							
		1	2	3	4	5	dal 6 al 7 from 6 to 7	dal 8 al 9 from 8 to 9	10 e superiori 10 and above
400.1	Guarnizioni idrauliche (Set) Hydraulic gaskets (Set)	2	4	4	5	6	8	8	80%
400.4									
400.5									
400.6									
400.7									
412.3									
Per pompe con tenute meccaniche For pumps with mechanical seals									
433.1	Complete Mechanical Seal (Set) Complete Mechanical Seal (Set)	1	2	2	2	3	3	4	40%
433.2									
Per pompe con baderne For pumps with packings glands									
461	Baderne (Set) Packing glands (Set)	2	4	4	6	6	6	8	100%

Grid area for notes, consisting of a large dotted grid pattern.

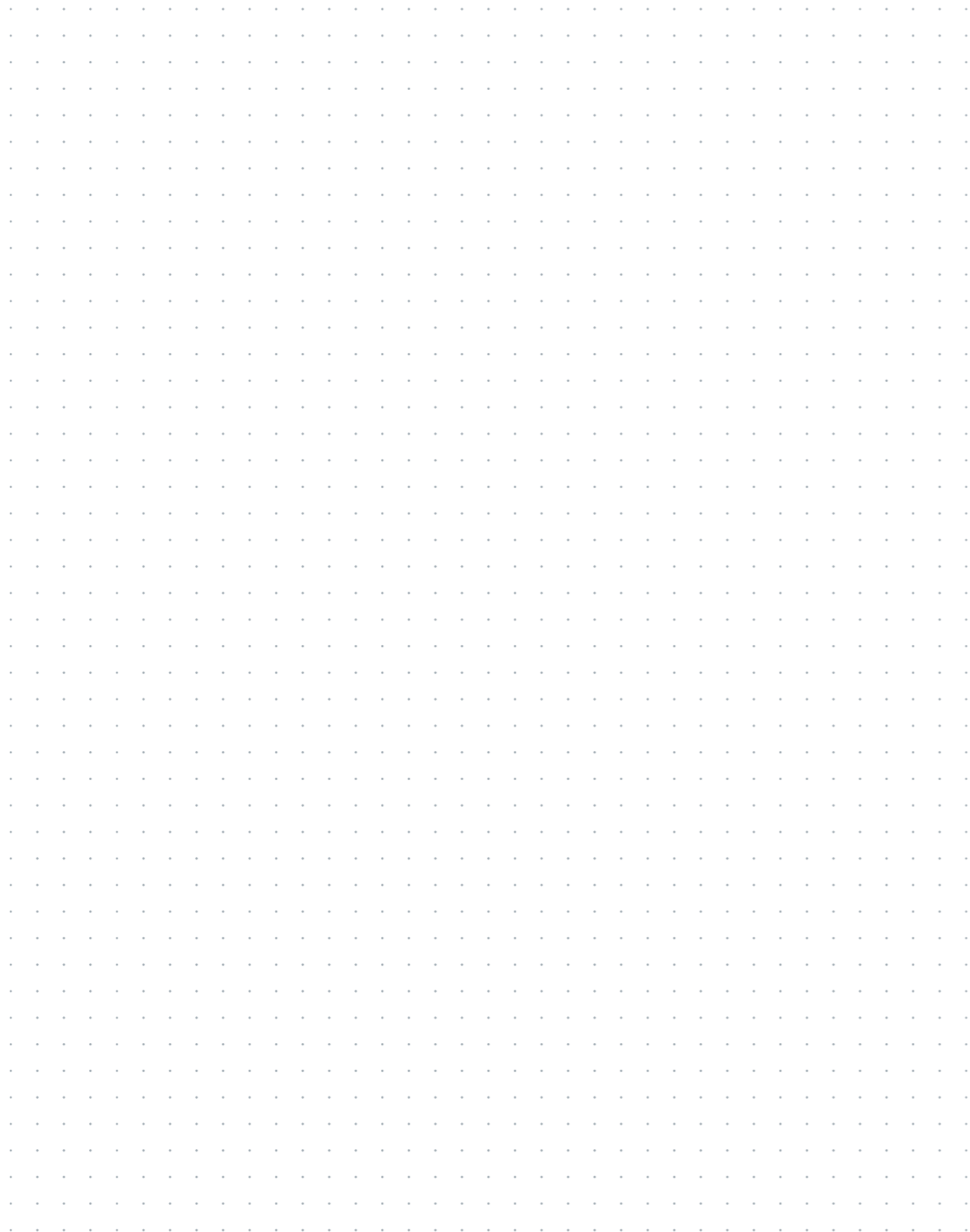

Salvatore Robuschi & C. srl
via Emilio Gino Segrè 11/a
43122 Parma | Italy

t +39 (0)521 606285
f +39 (0)521 606278

salvatorerobuschi.com
srpumps.com

sr@salvatorerobuschi.com

