

# RB-RE

**GIRANTE MULTI-CANALE CHIUSA E APERTA**  
**CLOSED AND OPEN MULTI-CHANNEL IMPELLER**

EN ISO 5199



RB - RE

Tutti i diritti sono riservati, anche per quanto riguarda l'eventuale cessione, riproduzione, modifica, distribuzione dei dati.  
Tutti i marchi, i diritti di proprietà sono di proprietà della Società.  
La nostra politica è quella del miglioramento continuo del prodotto.  
Salvatore Robuschi Pumps si riserva il diritto di modificare i propri prodotti senza preavviso.  
I dati riportati in questo catalogo, hanno lo scopo primario di descrivere il prodotto.  
Dalle informazioni non è possibile dedurre alcuna conferma relativa a condizioni di funzionamento o idoneità per una specifica applicazione. Le informazioni fornite non esonerano l'utente dall'obbligo e dalla responsabilità del proprio giudizio e verifica.

*All rights reserved, also regarding any disposal, reproduction, editing, distribution of data.  
All trademarks and the property rights are property of the Company. Our policy is one of continuous product improvement. Salvatore Robuschi Pumps reserves the right to modify its products without prior notice.  
The data reported in this catalogue have the primary purpose of describing the product. No confirmation regarding operating conditions or suitability for a specific application can be deduced from these information.  
The information provided by the Company does not release the user from the obligation of own judgment and verification.*

La nostra gamma di pompe centrifughe multi-canale comprende due diverse tipologie di giranti: giranti chiuse (RB) e giranti aperte (RE), entrambe conformi alla normativa EN ISO 5199.

Passaggio di corpi solidi, liquidi ad alta viscosità, basso NPSH ed elevato rendimento; sono le caratteristiche principali di questa serie che consentono di raggiungere eccellenti prestazioni anche in condizioni critiche. La grande sezione di imbocco e il basso numero di pale garantiscono ottime capacità di aspirazione anche in presenza di gas e aria disciolta.

La geometria delle pale è stata studiata per ottimizzare le velocità interne alla girante, migliorare le prestazioni anche in presenza di liquidi viscosi, trasferire corpi solidi (non filamentosi) senza che la pompa si intasi pur mantenendo alti rendimenti.

Le pompe centrifughe RB-RE sono macchine di uso specialistico e di eccezionale versatilità, adatte alla maggior parte degli usi e degli impianti.

*Our range of multi-channel centrifugal pumps includes two types of impellers: closed impellers (RB) and open impellers (RE) that both comply with EN ISO 5199.*

*Passage of suspended solids, highly viscous liquids, low NPSH values and high efficiency are the main features of this series that can achieve great performance levels even in critical conditions. This series can guarantee an excellent suction capacity even in spite of dissolved gases and air, thanks to its big inlet and few impeller blades number.*

*Blades geometry is designed to optimize internal speed within the impeller, improve the pump performance even with viscous liquids and convey solid but non-filamentous parts without any risk of clogging the pump while maintaining its high efficiency.*

*RB-RE centrifugal pumps are suitable for special and versatile conditions and adjust to most facilities and applications.*

# RB-RE

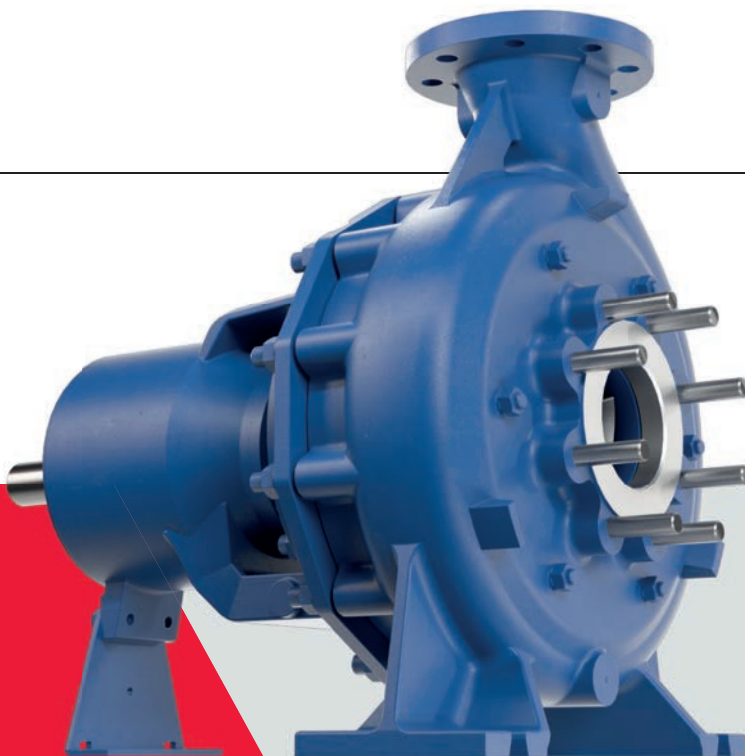

## IMPIEGHI

Pompaggio di liquidi leggermente contaminati negli impianti di trattamento delle acque reflue, acqua pulita per torri di raffreddamento o impianti di recupero della condensa, liquidi viscosi negli evaporatori dell'industria alimentare o chimica. Raffinerie, servizi industriali generali, cartiere, zuccherifici, industria alimentare, impianti di desalinizzazione dell'acqua di mare, centrali elettriche, industrie siderurgiche.

## VANTAGGI

Trasporto di liquidi contenenti solidi sospesi, come fanghi, detriti o liquidi viscosi.  
Maggior resistenza all'incrostazione e alla formazione di depositi rispetto alle giranti chiuse standard.  
La geometria dei canali aiuta a mantenere il flusso e a prevenire ostruzioni.  
Elevata efficienza e bassi NPSH.

## MODULARITÀ

4 diversi gruppi di supporto cuscinetti per 15 diverse taglie.

## USE

Handling slightly contaminated liquids in waste-water treatment plants, clean water for cooling towers or condensate recovery plants, viscous liquids in evaporators of food or chemical industry. Refineries, general industrial service, paper mills, food industry, sugar industry, sea water desalination plants, power stations, steel industries.

## ADVANTAGES

Conveying liquids containing suspended solids, such as sludge, debris or viscous liquids. Greater resistance to fouling and dirt build-up than standard closed impellers. Multi-Channel geometry helps maintain the liquid flow and prevent clogging. High efficiency and Low NPSH.

## MODULARITY

4 different groups of bearing housing for 15 different sizes.

# RB

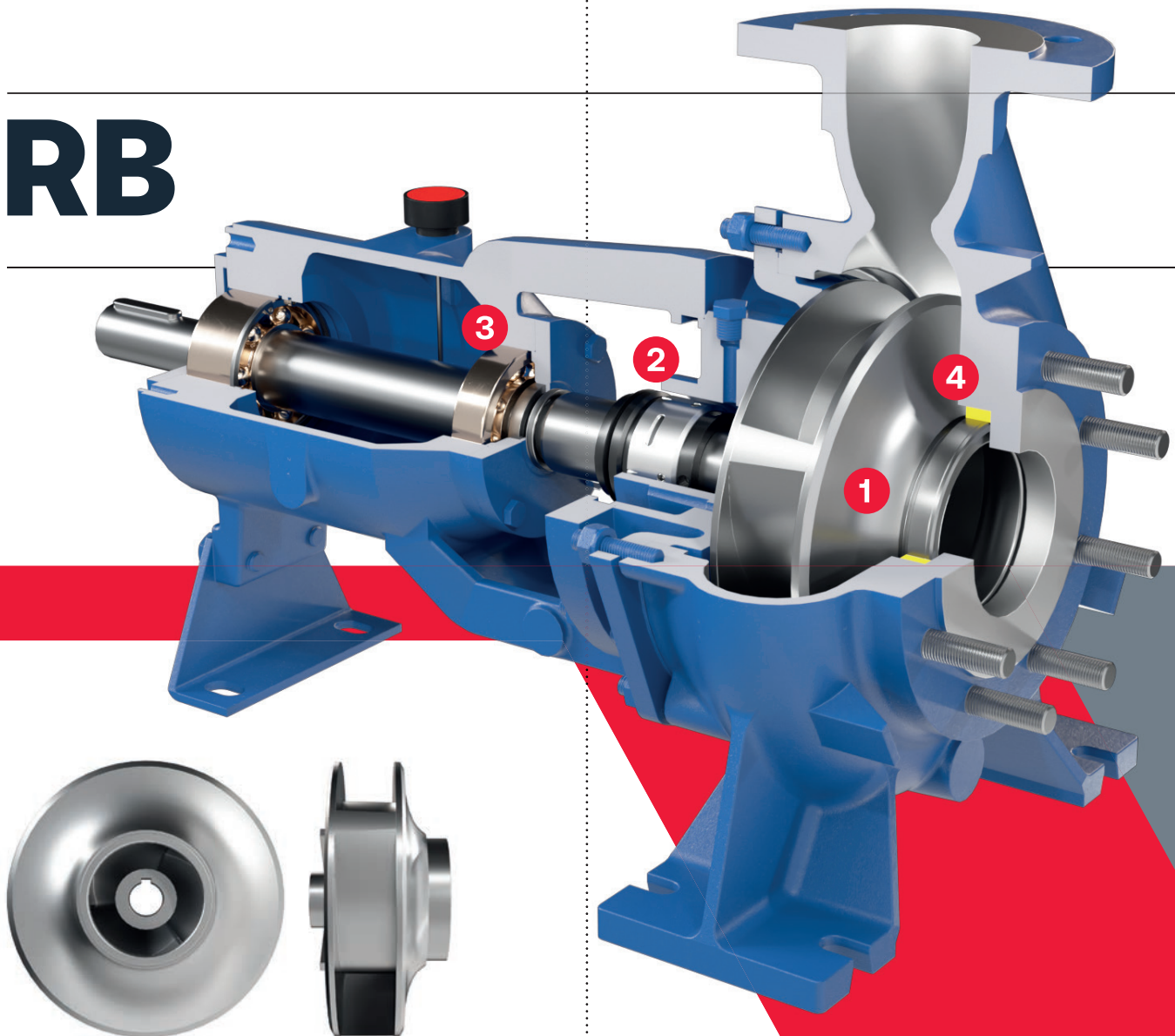

Girante a canali/Channel impeller

**1****1 SOLO CORPO, 2 GIRANTI**

Per ciascuna grandezza esiste un unico corpo che può essere impiegato sia con girante chiusa (dotata di anello di usura) che con girante aperta (con piastra di usura sostituibile). Questa versatilità permette di adattare facilmente la pompa ad eventuali nuove esigenze di impianto o processo.

**1 CASING, 2 IMPELLERS**

Every size of pumps can use a unique casing that both applies to closed impellers (provided with a wearing ring) and open impellers (with replaceable wearing plate). This versatility allows the pump to be easily used in new plants and processes.

**2****1 SOLO COPERCHIO, 12 SISTEMI DI TENUTA**

Per ciascuna grandezza esiste un unico coperchio in grado di accogliere qualsiasi tipo, marca e soluzione di tenuta. La camera di tenuta è stata dimensionata per garantire un'adeguata ed efficace circolazione del liquido. Sostituendo pochi componenti è possibile modificare facilmente l'esecuzione del sistema di tenuta, adattando velocemente la pompa ad eventuali nuove esigenze di impianto o processo e riducendo così il magazzino ricambi. Tenute meccaniche secondo standard EN 12756.

**1 CASING, 12 SEAL ARRANGEMENTS**

For every size of pump, a unique casing can hold any kind, brand and choice of seal. The seal chamber dimensions are designed to guarantee an efficacious and correct liquid circulation. By changing a few components, the seal arrangement can be easily modified, thus making the pump ready for new plant or process requirements and reducing the spares stock. Mechanical Seals comply with EN 12756 standard.

**3****SUPPORTO HEAVY DUTY EN ISO 5199**

Il supporto cuscinetti è unificato secondo EN ISO 5199 e garantisce flessioni dell'albero < 0,05 mm e un minimo di 18.000 ore di funzionamento. È studiato per ripartire al meglio i carichi assiali e radiali in modo da ridurre drasticamente le temperature di esercizio. Tutti i supporti sono predisposti per ospitare la versione pesante "HD" equipaggiata con cuscinetti accoppiati a contatto obliquo e cuscinetto a rulli. La serie contempla anche supporti maggiorati per funzionamento fino a 100.000 ore.

**HEAVY DUTY BEARING HOUSING EN ISO 5199**

The bearing housing is standardized according to EN ISO 5199 and guarantees a shaft deflection < 0,05 mm and a minimum of 18.000 working hours. It is designed to optimize axial and radial thrusts as to drastically reduce operating temperatures. All bearing housings are suitable to host the heavy duty version "HD" which is equipped with angular contact bearings and roller bearings. These series also include a stronger bearing housing able to operate up to 100.000 working hours.

**4****ANELLO DI USURA**

La pompa è dotata di anello di usura sostituibile.

**WEARING RING**

The pump is provided with a replaceable wearing ring.

- Tipo girante  
**Chiusa multi-canale**
- Dimensioni bocca di mandata  
**da DN 65 a DN 400**
- Pressione massima di esercizio  
**10 bar**
- Portata  
**Fino a 3.100 m<sup>3</sup>/h**
- Prevalenza  
**Fino a 70 m**
- Temperatura  
**Fino a 220°C in funzione del liquido pompato**
- Flange  
**EN 1092 PN10, a richiesta forate ANSI B16.5 150**
- Materiali  
**Standard: Ghisa, AISI 316, Superduplex (dimensioni dalla 80 alla 125).  
A richiesta: AISI 904L e altre leghe**

- Impeller type  
**Closed multi-channel**
- Discharge sizes  
**From DN 65 to DN 400**
- Maximum working pressure  
**10 bar**
- Flow rate  
**Up to 3,100 m<sup>3</sup>/h**
- Differential head  
**Up to 70 m**
- Temperature  
**Up to 220°C according to the pumped liquid**
- Flange  
**EN 1092 PN10, on request ANSI B16.5 150# drilled**
- Materials  
**Standard: Cast Iron, AISI 316, Superduplex (sizes from 80 to 125).  
On request: AISI 904L and other alloys**

## IMPIEGHI

Pompaggio di liquidi leggermente contaminati in impianti di trattamento delle acque reflue, pasta di carta fino all'8%, industria dello zucchero, fertilizzanti, liquidi viscosi in evaporatori nell'industria alimentare o chimica, raffinerie, servizi industriali generali, industria alimentare, impianti di desalinizzazione dell'acqua di mare, centrali elettriche, industrie siderurgiche.

## VANTAGGI

Configurazione aperta per il trasporto di liquidi contenenti solidi sospesi non abrasivi, liquidi viscosi, liquidi con cristalli in sospensione. La geometria dei canali aiuta a mantenere il flusso e a prevenire ostruzioni. Bassi NPSH.

## MODULARITÀ

3 diversi gruppi di supporto cuscinetti per 10 diverse taglie (in progress).

## USE

Handling slightly contaminated liquids in waste-water treatment plants, paper pulp up to 8%, sugar industry, fertilizer, viscous liquids in evaporators of food or chemical industry, refineries, general industrial service, food industry, sea water desalination plants, power stations, steel industries.

## ADVANTAGES

Open configuration for conveying liquids containing non-abrasive suspended solids, viscous liquids, liquids with suspended crystals. Multi-Channel geometry helps maintain the liquid flow and prevent clogging. Low NPSH.

## MODULARITY

3 different groups of bearing housing for 10 different sizes (in progress).

# RE

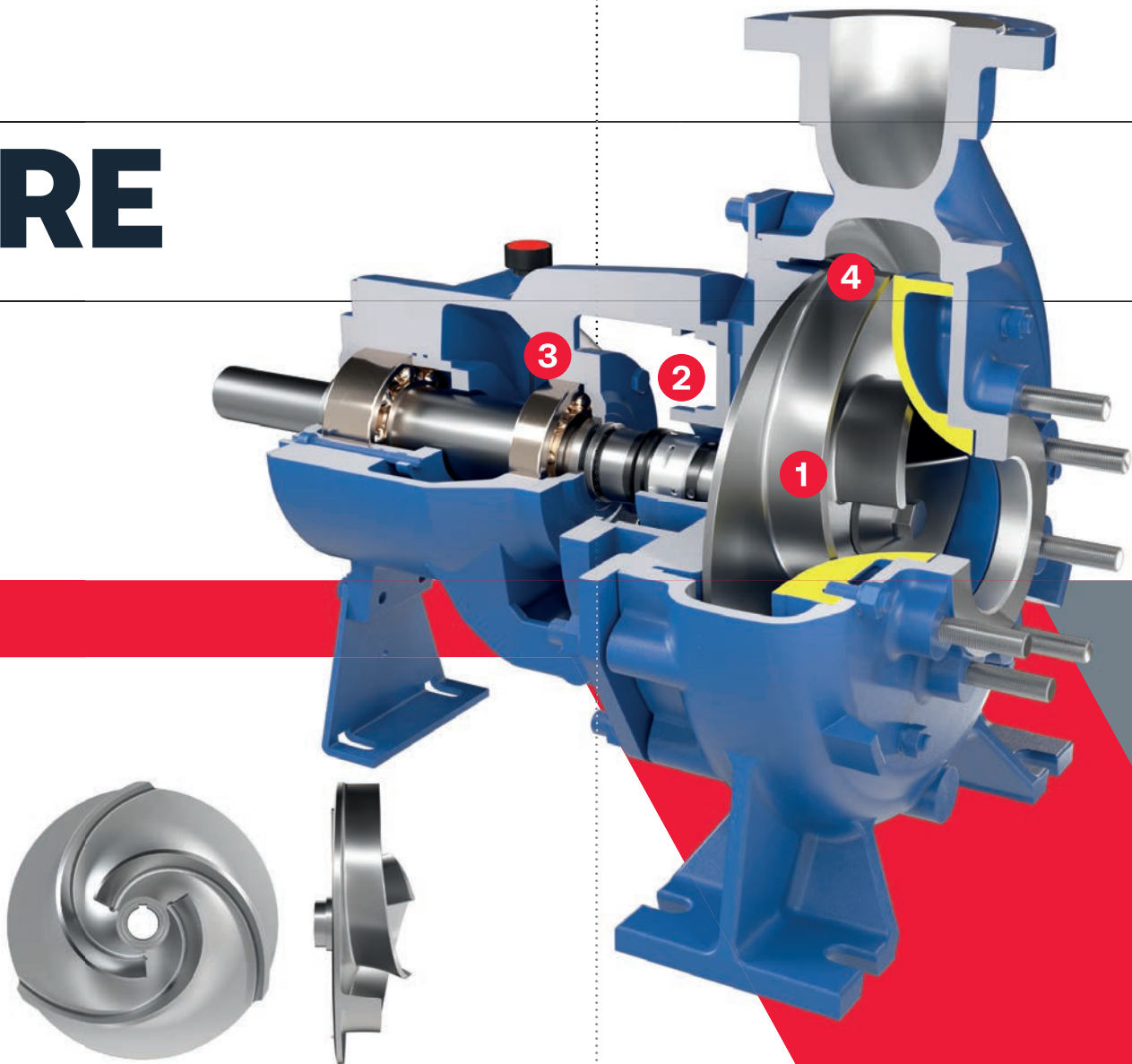

Girante aperta a canali/Open channel impeller

**1****1) 1 SOLO CORPO, 2 GIRANTI**

Per ciascuna grandezza esiste un unico corpo che può essere impiegato sia con girante chiusa (dotata di anello di usura) che con girante aperta (con piastra di usura sostituibile). Questa versatilità permette di adattare facilmente la pompa ad eventuali nuove esigenze di impianto o processo.

**1 CASING, 2 IMPELLERS**

Every size of pumps can use a unique casing that both applies to closed impellers (provided with a wearing ring) and open impellers (with replaceable wearing plate). This versatility allows the pump to be easily used in new plants and processes.

**2****2) 1 SOLO COPERCHIO, 12 SISTEMI DI TENUTA**

Per ciascuna grandezza esiste un unico coperchio in grado di accogliere qualsiasi tipo, marca e soluzione di tenuta. La camera di tenuta è stata dimensionata per garantire un'adeguata ed efficace circolazione del liquido. Sostituendo pochi componenti è possibile modificare facilmente l'esecuzione del sistema di tenuta, adattando velocemente la pompa ad eventuali nuove esigenze di impianto o processo e riducendo così il magazzino ricambi. Tenute meccaniche secondo standard EN 12756.

**1 CASING, 12 SEAL ARRANGEMENTS**

For every size of pump, a unique casing can hold any kind, brand and choice of seal. The seal chamber dimensions are designed to guarantee an efficacious and correct liquid circulation. By changing a few components, the seal arrangement can be easily modified, thus making the pump ready for new plant or process requirements and reducing the spares stock. Mechanical Seals comply with EN 12756 standard.

**3****SUPPORTO HEAVY DUTY EN ISO 5199**

Il supporto cuscinetti è unificato secondo EN ISO 5199 e garantisce flessioni dell'albero < 0,05 mm e un minimo di 18.000 ore di funzionamento. È studiato per ripartire al meglio i carichi assiali e radiali in modo da ridurre drasticamente le temperature di esercizio. Tutti i supporti sono predisposti per ospitare la versione pesante "HD" equipaggiata con cuscinetti accoppiati a contatto obliquo e cuscinetto a rulli. La serie contempla anche supporti maggiorati per funzionamento fino a 100.000 ore.

**HEAVY DUTY BEARING HOUSING EN ISO 5199**

The bearing housing is standardized according to EN ISO 5199 and guarantees a shaft deflection < 0,05 mm and a minimum of 18.000 working hours. It is designed to optimize axial and radial thrusts as to drastically reduce operating temperatures. All bearing housings are suitable to host the heavy duty version "HD" which is equipped with angular contact bearings and roller bearings. These series also include a stronger bearing housing able to operate up to 100.000 working hours.

**4****PIASTRA DI USURA E REGISTRAZIONE**

La piastra di usura sostituibile garantisce lunga vita alla pompa e riduce i costi di manutenzione. Il supporto cuscinetti è inoltre dotato di registrazione assiale dei giochi facilmente modulabile dal lato comando.

**WEARING PLATE AND ADJUSTMENT**

The replaceable wearing plate guarantees a long lasting pump's lifetime and reduces maintenance costs. Furthermore, bearing housing is equipped with axial adjustment of clearances that is easily accessible from drive side.

- Tipo girante  
**Aperta multi-canale**
- Dimensioni bocca di mandata  
**da DN 80 a DN 125 (fino a DN250 in futuro)**
- Pressione massima di esercizio  
**10 bar**
- Portata  
**Fino a 500 m<sup>3</sup>/hr**
- Prevalenza  
**Fino a 50 m**
- Temperatura  
**Fino a 220°C in funzione del liquido pompato**
- Flange  
**EN 1092 PN10, a richiesta forate ANSI B16.5 150#**
- Materiali  
**Standard: Ghisa, AISI 316, Superduplex (dimensioni dalla 80 alla 125).  
A richiesta: AISI 904L e altre leghe**

- Impeller type  
**Open multi-channel**
- Discharge sizes  
**From DN 80 to DN 125 (up to 250 in progress)**
- Maximum working pressure  
**10 bar**
- Flow rate  
**Up to 500 m<sup>3</sup>/hr**
- Differential head  
**Up to 50 m**
- Temperature  
**Up to 220°C according to the pumped liquid**
- Flange  
**EN 1092 PN10, on request ANSI B16.5 150# drilled**
- Materials  
**Standard: Cast Iron, AISI 316.  
On request: Superduplex, AISI 904L and other alloys**

Sigla di identificazione  
Identification mark

Girante multi-canale chiusa e aperta  
Closed and open multi-channel impeller

<b>1</b>	<b>2</b>	<b>3</b>	<b>4</b>	<b>5</b>	<b>6</b>	<b>7</b>	<b>8</b>	<b>9</b>
RBB	80 20	A	4	A75	C	181	3	/A

**1 Esecuzione pompa**

<b>RBB-REB</b>	Pompa asse nudo/asse nudo su base
<b>RBL-REL</b>	Pompa lanternata
<b>RBM-REM</b>	Pompa monoblocco

**1 Pump arrangement**

<b>RBB-REB</b>	Bare shaft pump/bare shaft pump on base
<b>RBL-REL</b>	Lantern bracket pump
<b>RBM-REM</b>	Close coupled pump

**2 Grandezza pompa**

<b>80-20</b>	
<b>80</b>	Diametro bocca di mandata (mm)
<b>20</b>	Diametro Nominale Girante (cm)

**2 Pump size**

<b>80-20</b>	
<b>80</b>	Discharge port diameter (mm)
<b>20</b>	Nominal impeller diameter (cm)

**3 Riduzione girante**

<b>A</b>	Diametro massimo
<b>B</b>	1° riduzione
<b>C</b>	2° riduzione
<b>AR</b>	Riduzione intermedia (tra A e B)

**3 Impeller trim**

<b>A</b>	Maximum diameter
<b>B</b>	1° trim
<b>C</b>	2° trim
<b>AR</b>	Intermediate trim (between A and B)

**4 Polarità motore**

<b>0000</b>	Pompa asse nudo senza base
<b>2</b>	Motore elettrico a 2 poli
<b>4</b>	Motore elettrico a 4 poli
<b>6</b>	Motore elettrico a 6 poli
<b>8</b>	Motore elettrico a 8 poli

**4 Motor polarity**

<b>0000</b>	Bare shaft pump without base
<b>2</b>	2 poles electric motor
<b>4</b>	4 poles electric motor
<b>6</b>	6 poles electric motor
<b>8</b>	8 poles electric motor

**5 Potenza motore elettrico**

<b>0000</b>	Pompa asse nudo senza base
<b>A</b>	0,25-0,75 kW
<b>B</b>	1,1-9,2 kW
<b>C</b>	11-90 kW
<b>D</b>	110-400 kW

**5 Electric motor power**

<b>0000</b>	Bare shaft pump without base
<b>A</b>	0.25-0.75 kW
<b>B</b>	1.1-9.2 kW
<b>C</b>	11-90 kW
<b>D</b>	110-400 kW

<b>A</b>	<b>kW</b>	0,25	0,37	0,55	0,75
	<b>Cod</b>	<b>A25</b>	<b>A37</b>	<b>A55</b>	<b>A75</b>

<b>B</b>	<b>kW</b>	1,1	1,5	2,2	3,0	4,0	5,5	7,5	9,2
	<b>Cod</b>	<b>B11</b>	<b>B15</b>	<b>B22</b>	<b>B30</b>	<b>B40</b>	<b>B55</b>	<b>B75</b>	<b>B92</b>

<b>C</b>	<b>kW</b>	11	15	18,5	22	30	37	45	55	75	90
	<b>Cod</b>	<b>C11</b>	<b>C15</b>	<b>C18</b>	<b>C22</b>	<b>C30</b>	<b>C37</b>	<b>C45</b>	<b>C55</b>	<b>C75</b>	<b>C90</b>

<b>D</b>	<b>kW</b>	110	132	160	200	225	250	280	315	355	400
	<b>Cod</b>	<b>D11</b>	<b>D13</b>	<b>D16</b>	<b>D20</b>	<b>D22</b>	<b>D25</b>	<b>D28</b>	<b>D31</b>	<b>D35</b>	<b>D40</b>

**6 Sistema di tenuta**

<b>Esecuzione U</b>	Tenuta meccanica singola
<b>Esecuzione B</b>	Tenuta a baderna senza flussaggio
<b>Esecuzione S</b>	Tenuta a baderna con flussaggio (solo in ingresso)
<b>Esecuzione H</b>	Camera di riscaldamento o raffreddamento
<b>Esecuzione C</b>	Tenuta meccanica doppia contrapposta
<b>Esecuzione L</b>	Tenuta meccanica doppia in tandem
<b>Esecuzione A</b>	Tenuta meccanica singola con bussola di fondo

**6 Sealing system**

<b>U Execution</b>	Single mechanical seal
<b>B Execution</b>	Gland packing without flushing
<b>S Execution</b>	Gland packing with flushing (inlet only)
<b>H Execution</b>	Heating or cooling chamber
<b>C Execution</b>	Double back to back mechanical seal
<b>L Execution</b>	Double tandem mechanical seal
<b>A Execution</b>	Single mechanical seal with throttle bushing

**7 Codice tenuta meccanica primaria**

**Nota**  
Per esecuzioni B e S = 000  
Per esecuzione K = 999  
H dopo codice tenuta indica camera riscaldamento o raffreddamento

**7 Primary mechanical seal Code**

**Note**  
For B and S executions = 000  
For K execution = 999  
H after mechanical seal code means casing heating or cooling chamber

**8 Codice componenti principali della pompa**

Per maggiori dettagli vedere la tabella T-2177 Codifica materiali

**8 Identification code for pump's parts**

For more details see table T-2177 Materials code

**9 Indice di revisione idraulica**

**9 Hydraulic release index**

**Dati tecnici**  
*Technical features*

**Girante multi-canale chiusa e aperta**  
*Closed and open multi-channel impeller*

Descrizione <i>Description</i>	Unità di misura <i>Unity of measurement</i>	Grandezze <i>Size</i>															
		(C) 65-20	(C) 80-20	(C) 80-25	(C) 100-25	(C) 125-25	80-31	125-31	125-40	(C) 150-31	(C) 150-35	(C) 200-35	(C) 250-35	(C) 200-45	(C) 250-45	(C) 300-45	(C) 400-60
Gruppo supporto <i>Bearing housing group</i>		GR2					GR3			GR4			GR5			GR6	
<b>Girante</b> <i>Impeller</i>																	
Luce di uscita girante <i>Impeller width</i>	mm	30*40	28*46	40*40	35*65	30*80	45*70	35*80	40*54	28*70	40*75	35*90	40*110	60*60	60*70	50*90	50*130
Momento di inerzia J <sup>(a)</sup> <i>Moment of inertia J<sup>(a)</sup></i>	kgm <sup>2</sup>	31	33,8	76,5	59,9	59,9	163	218	527	259	364	394	434	1110	1220	1430	5450
<b>Cassa stoppa</b> <i>Seal chamber</i>																	
Diametro interno <i>Internal Diameter</i>	mm	68					80			100			122			150	
Diametro tenuta meccanica <i>Mechanical seal diameter</i>	mm	43					53			70			90			100	
<b>Camera di raffreddamento</b> <sup>(b)</sup> <i>Cooling jacket</i> <sup>(b)</sup>																	
Pressione massima <i>Maximum pressure</i>	bar	3					3			3			3			3	
Pressione di prova <i>Maximum hydrostatic pressure</i>	bar	4,5					4,5			4,5			4,5			4,5	
Connessioni <i>Connections holes</i>		G 3/8					G 3/8			G 3/8			G 3/8			G 3/8	
<b>Supportazione standard</b> <i>Standard bearings</i>																	
Lato pompa <i>Pump side</i>		6307					6310			6313			6317			NU320	
Lato motore <i>Motor side</i>		3307					3310			3313			3317			2x7320	
<b>Supportazione pesante 1</b> <i>Heavy Duty Bearings 1</i>																	
Lato pompa <i>Pump side</i>		NJ 307					NJ 310			NJ 313			NJ 317			N.D.	
Lato motore <i>Motor side</i>		2x7307					2x7310			2x7313			2x7317			N.D.	

(a) Dividi per 1.000 per ottenere il momento di inerzia J in kgm<sup>2</sup>  
*Divide by 1.000 to obtain the moment of inertia J in kgm<sup>2</sup>*

(b) A richiesta  
*On demand*

(c) Solo per RB  
*Only for RB type*

Per condizioni di lavoro diverse, consultate il nostro servizio tecnico commerciale.  
*Please contact SR pumps representative for specific working condition.*

**Limiti di pressione e di temperatura**

**Pressure and temperature limits**

In presenza di rischi significativi di corrosione, i limiti di pressione potrebbero essere inferiori rispetto a quelli indicati. Per applicazioni con requisiti di lavoro diversi, contattare il nostro servizio tecnico commerciale per valutare le condizioni operative ottimali.

*If there is a considerable risk of corrosion, pressure limits could be lower than those displayed. Please contact SR technical service for applications with different working requirements, in order to define the best operational conditions.*

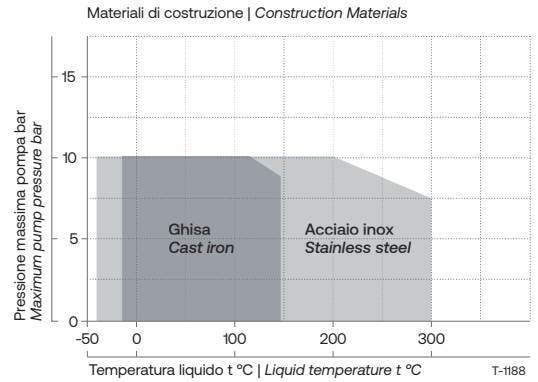

Descrizione	Description	Codice materiale pompa   Pumps material code							
		0	1	2	3	4	5	6	7
Corpo	Casing	GJL 250	GJL 250	GJL 250	CF8M (AISI 316)	GJL 250	CF3M (AISI 316L)	AISI 904L	SAF 2205
Coperchio del corpo	Casing cover	GJL 250	GJL 250	GJL 250	CF8M (AISI 316)	GJL 250	CF3M (AISI 316L)	AISI 904L	SAF 2205
Girante	Impeller	GJL250/GJS400	GJL250/GJS400	CF8M (AISI 316)	CF8M (AISI 316)	CF8M (AISI 316)	CF3M (AISI 316L)	AISI 904L	SAF 2205
Albero gruppo 1-2	Shaft group 1-2	AISI 316L	AISI 420	AISI 316L	AISI 316L	AISI 420	AISI 316L	AISI 316L(*)	AISI 316L(*)
Albero gruppo 3-4-5-6	Shaft group 3-4-5-6	C45(*)	C45(*)	C45(*)	C45(*)	C45(*)	C45(*)	C45(*)	C45(*)
Albero monoblocco	Shaft closed couple	AISI 316L	AISI 316L	AISI 316L	AISI 316L	AISI 316L	AISI 316L	AISI 316L(*)	AISI 316L(*)
Camicia albero	Shaft sleeve	AISI 316L	AISI 420	AISI 316L	AISI 316L	AISI 420	AISI 316L	AISI 904L	SAF2507
Piede sostegno	Support foot	S 235 JR	S 235 JR	S 235 JR	S 235 JR	S 235 JR	S 235 JR	S 235 JR	S 235 JR
Supporto	Bearing housing	GJL 200	GJL 200	GJL 200	GJL 200	GJL 200	GJL 200	GJL 200	GJL 200
Lanterna	Lantern bracket	GJL200/GJL250/S 235 JR	GJL200/GJL250/S 235 JR	GJL200/GJL250/S 235 JR	GJL200/GJL250/S 235 JR	GJL200/GJL250/S 235 JR	GJL200/GJL250/S 235 JR	GJL200/GJL250/S 235 JR	GJL200/GJL250/S 235 JR
Coperchio tenuta singola	Single mechanical seal cover	GJL 250	GJL 250	GJL 250	AISI 316L	GJL 250	AISI 316L	AISI 904L	SAF 2507 SAF 2205
Coperchio tenuta doppia	Double mechanical seal cover	C40	C40	C40	AISI 316L	C40	AISI 316L	AISI 316L	AISI 316L
Ogiva girante	Impeller hub	AISI 316L	AISI 316L	AISI 316L	AISI 316L	AISI 316L	AISI 316L	AISI 904L	SAF 2205
Anello usura	Wear ring	AISI 316L	AISI 316L	AISI 316L	AISI 316L	AISI 316L	AISI 316L	AISI 904L	SAF 2205
Piastra usura	Wear plate	AISI 316L	AISI 316L	AISI 316L	AISI 316L	AISI 316L	AISI 316L	AISI 904L	SAF 2205

(\*) Non in contatto con liquido pompato

(\*) Not in contact with pumped liquid

Descrizione	Description	Codice materiale pompa   Pumps material code							
		8	9	A	B	C	D	E	S
Corpo	Casing	SAF2507	HASTELLOY B	HASTELLOY C	CF3M (AISI 316L)	CF8M (AISI 316)	AISI 329	SANICRO 28	ON DEMAND
Coperchio del corpo	Casing cover	SAF2507	HASTELLOY B	HASTELLOY C	CF3M (AISI 316L)	CF8M (AISI 316)	AISI 329	SANICRO 28	ON DEMAND
Girante	Impeller	SAF2507	HASTELLOY B	HASTELLOY C	CF3M (AISI 316L)	CF8M (AISI 316)	AISI 329	SANICRO 28	ON DEMAND
Albero gruppo 1-2	Shaft group 1-2	AISI 316L <sup>(*)</sup>	AISI 316L <sup>(*)</sup>	AISI 316L <sup>(*)</sup>	AISI 316L <sup>(*)</sup>	AISI 316L <sup>(*)</sup>	AISI 316L <sup>(*)</sup>	AISI 316L <sup>(*)</sup>	ON DEMAND
Albero gruppo 3-4-5-6	Shaft group 3-4-5-6	C45 <sup>(*)</sup>	C45 <sup>(*)</sup>	C45 <sup>(*)</sup>	C45 <sup>(*)</sup>	C45 <sup>(*)</sup>	C45 <sup>(*)</sup>	C45 <sup>(*)</sup>	ON DEMAND
Albero monoblocco	Shaft closed couple	AISI 316L <sup>(*)</sup>	AISI 316L <sup>(*)</sup>	AISI 316L <sup>(*)</sup>	AISI 316L <sup>(*)</sup>	AISI 316L <sup>(*)</sup>	AISI 316L <sup>(*)</sup>	AISI 316L <sup>(*)</sup>	ON DEMAND
Camicia albero	Shaft sleeve	SAF2507	HASTELLOY B	HASTELLOY C	AISI 304L	AISI 304	AISI 329	AISI 904L	ON DEMAND
Piede sostegno	Support foot	S 235 JR	S 235 JR	S 235 JR	S 235 JR	S 235 JR	S 235 JR	S 235 JR	ON DEMAND
Supporto	Bearing housing	GJL 200	GJL 200	GJL 200	GJL 200	GJL 200	GJL 200	GJL 200	GJL 200
Lanterna	Lantern bracket	GJL200/ GJL250/ S 235 JR	GJL200/ GJL250/ S 235 JR	GJL200/ GJL250/ S 235 JR	GJL200/ GJL250/ S 235 JR	GJL200/ GJL250/ S 235 JR	GJL200/ GJL250/ S 235 JR	GJL200/ GJL250/ S 235 JR	GJL200/ GJL250/ S 235 JR
Coperchio tenuta singola	Single mechanical seal cover	SAF2507	HASTELLOY B	HASTELLOY C	CF8M (AISI 304)	CF8M (AISI 304)	AISI 329	AISI 904L SANICRO 28	ON DEMAND
Coperchio tenuta doppia	Double mechanical seal cover	AISI 316L	AISI 316L	AISI 316L	AISI 316L	AISI 316L	AISI 316L	AISI 316L	ON DEMAND
Ogiva girante	Impeller hub	SAF2507	HASTELLOY B	HASTELLOY C	AISI 304L	AISI 304	AISI 329	AISI 904L	ON DEMAND
Anello usura	Wear ring	SAF2507	HASTELLOY B	HASTELLOY C	AISI 304L	AISI 304	AISI 329	SANICRO 28	ON DEMAND
Piastra usura	Wear plate	SAF2507	HASTELLOY B	HASTELLOY C	AISI 304L	AISI 304	AISI 329	SANICRO 28	ON DEMAND

(\*) Non in contatto con liquido pompato

(\*) Not in contact with pumped liquid

**Dati tecnici**  
*Technical features*

**Girante multi-canale chiusa e aperta**  
*Closed and open multi-channel impeller*

**Esecuzione C**  
*C execution*

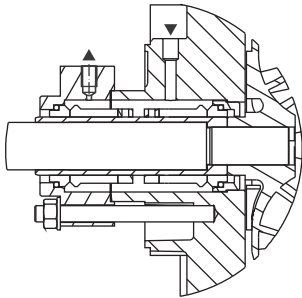

**Esecuzione L**  
*L execution*

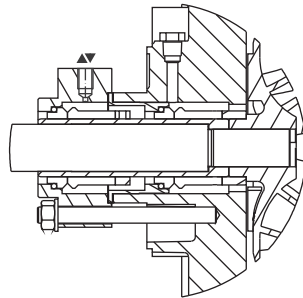

**Flussaggio tenuta meccanica doppia esecuzione C - L**  
*Double mechanical seal flushing C - L exec.*

Supporto <i>Bearing housing</i>	Dia. ten. mecc. <i>Mech. seal dia. (mm)</i>	Portata flusso <i>Flushing capacity (l/min)</i>		P di flusso <i>Flushing pressure (bar)</i>	
		1450 rpm	960 rpm	C	L
GR2	43	1	0,66	0,5 > p mandata 0,5 > discharge p	< 0,3
GR3	53	1,5	1		
GR4	70	2	1,33		
GR5	90	2,5	1,66		
GR6	100	-	1,8		

**Esecuzione H**  
*H execution*

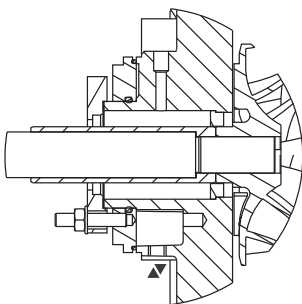

**Flussaggio camera di raffreddamento esecuzione H**  
*Cooling chamber flushing H execution*

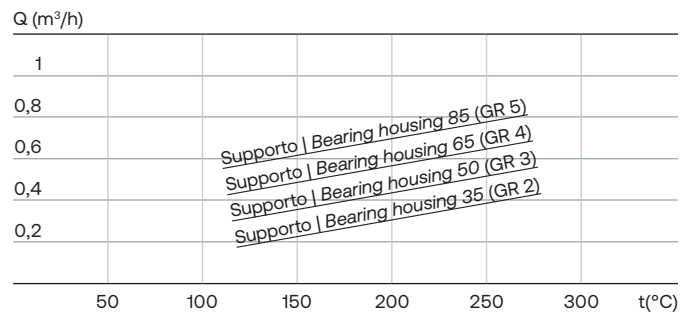

**Esecuzione S**  
*S execution*

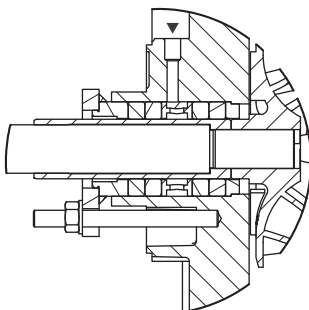

**Flussaggio tenuta a baderna esecuzione S**  
*Packing gland seal flushing S exec.*

Supporto <i>Bearing housing</i>	Dia. ten. mecc. <i>Mech. seal dia. (mm)</i>	Portata flusso <i>Flushing capacity (l/min)</i>		P di flusso <i>Flushing pressure (bar)</i>
		1450 rpm	960 rpm	
				S
GR2	43	1	0,66	0,5 > p mandata 0,5 > discharge p
GR3	53	1,5	1	
GR4	70	2	1,33	
GR5	90	2,5	1,66	

## RB - RE

Esecuzioni modulari  
Modular arrangements

Girante multi-canale chiusa e aperta  
Closed and open multi-channel impeller

Asse nudo  
Bare shaft

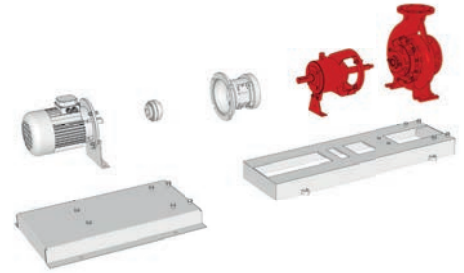

Asse nudo su base  
Bare shaft on base

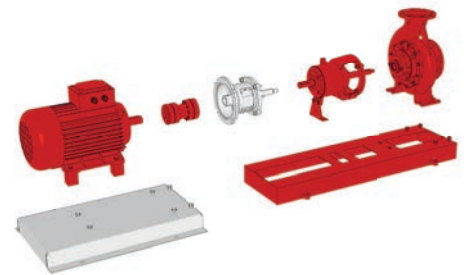
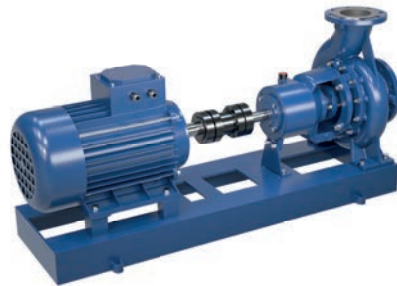

Lanternata  
Lantern bracket

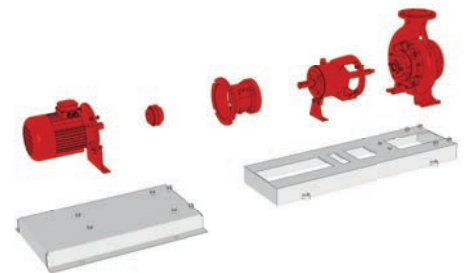

Lanternata su base  
Lantern bracket on base

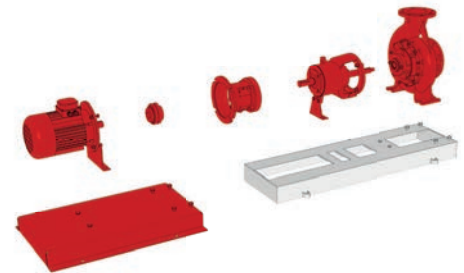

Monoblocco  
Close-coupled

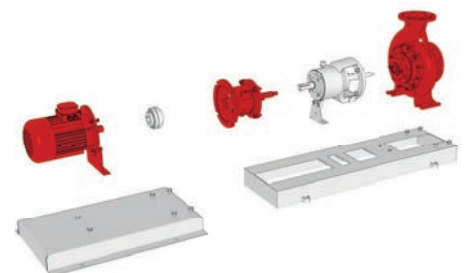

Parti in rosso usate per l'esecuzione.  
Red color parts used in the arrangement.

Dispositivi di tenuta e raffreddamento (o riscaldamento)  
*Sealing and cooling (or heating) device*

**Girante multi-canale chiusa e aperta**  
*Closed and open multi-channel impeller*

Tenuta meccanica singola  
*Single mechanical seal*

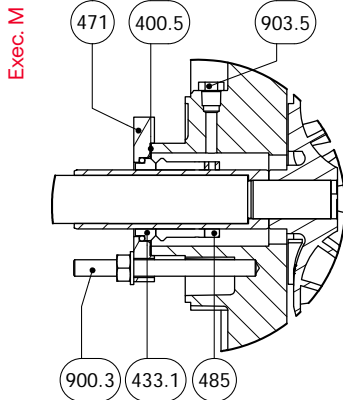

Singola flussata (con/senza bussola di fondo)  
*Single with flushing (with/without throttle-bush)*

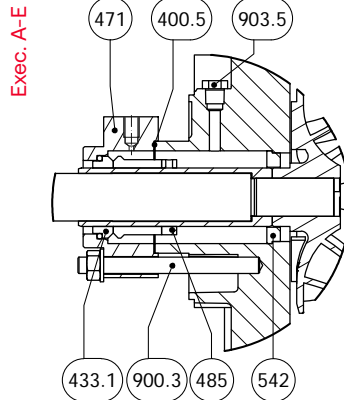

Tenuta a baderna  
*Packing gland*

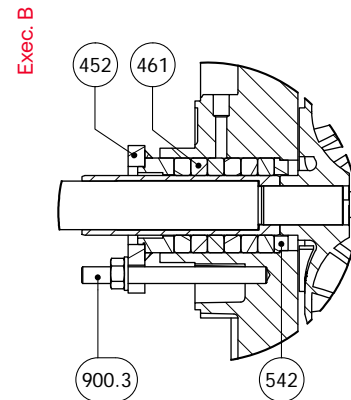

Tenuta a baderna flussata  
*Packing gland with flushing*

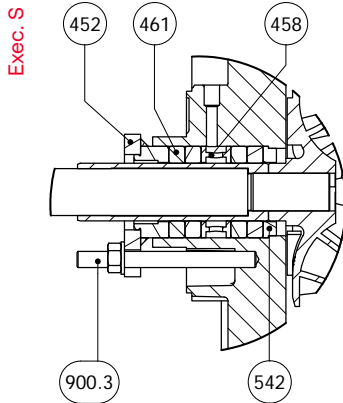

Tenuta meccanica doppia in tandem  
*Double tandem mechanical seal*

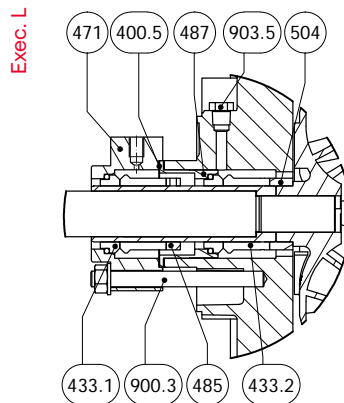

Tenuta meccanica doppia contrapposta  
*Double back to back mechanical seal*

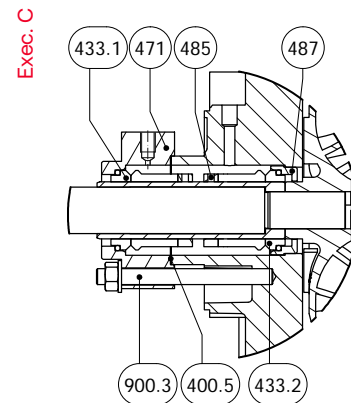

N.	Descrizione	Description
165	Coperchio camera di raffreddamento	Cooling chamber cover
452	Premitreccia	Packing gland
458	Anello idraulico	Lantern ring
461	Baderna	Packing ring
471	Coperchio tenuta meccanica	Seal chamber cover
485	Anello arresto tenuta meccanica	Abutment ring
486	Pumping ring	Pumping ring
487	Anello sede tenuta meccanica	Seal seat ring
504	Distanziale	Spacer
542	Bussola di fondo	Bottom sleeve
400.5	Guarnizione piana	Seal plate gasket

N.	Descrizione	Description
412.1	O-ring	O-ring
412.9	O-ring	O-ring
433.1	Tenuta meccanica L.C.	Mechanical seal D.S.
433.2	Tenuta meccanica L.O.C.	Mechanical seal N.D.S.
433.4	Paraolio	Lipseal
433.5	Quench	Quench
471.2	Coperchio flangiato tenuta meccanica	Seal chamber cover flange
487.1	Anello sede paraolio	Lipseal seat ring
900.3	Prigioniero con dado	Stud with nut
903.5	Tappo	Plug

Singola con pumping ring  
*Single with pumping ring*

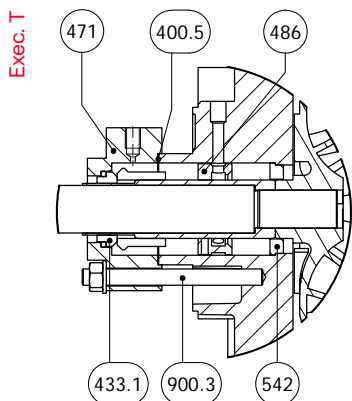

Singola ravvicinata  
*Single close to the impeller*

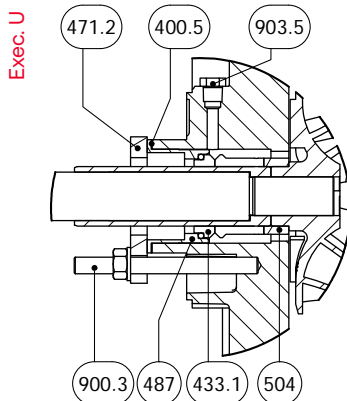

Singola con Quench  
*Single with Quench*

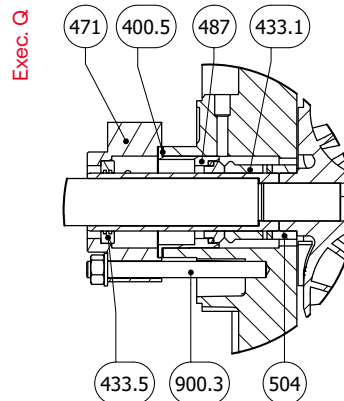

Singola con paraolio + grasso  
*Single with lipseal + grease*

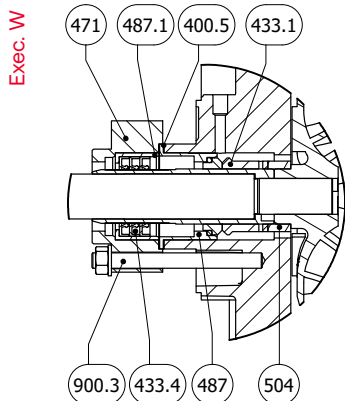

Tenuta a cartuccia  
*Cartridge seal*

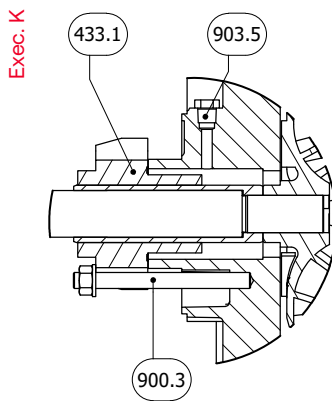

Camera riscaldamento/raffreddamento  
*Cooling/heating jacket*

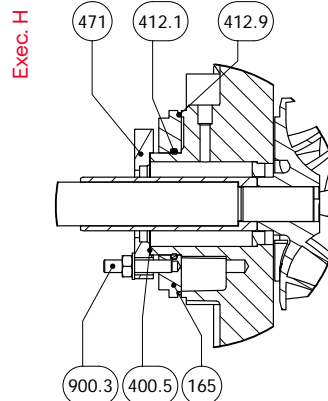

N.	Descrizione	Description
165	Coperchio camera di raffreddamento	Cooling chamber cover
452	Premi treccia	Packing gland
458	Anello idraulico	Lantern ring
461	Baderna	Packing ring
471	Coperchio tenuta meccanica	Seal chamber cover
485	Anello arresto tenuta meccanica	Abutment ring
486	Pumping ring	Pumping ring
487	Anello sede tenuta meccanica	Seal seat ring
504	Distanziale	Spacer
542	Bussola di fondo	Bottom sleeve
400.5	Guarnizione piana	Seal plate gasket

N.	Descrizione	Description
412.1	O-ring	O-ring
412.9	O-ring	O-ring
433.1	Tenuta meccanica L.C.	Mechanical seal D.S.
433.2	Tenuta meccanica L.O.C.	Mechanical seal N.D.S.
433.4	Paraolio	Lipseal
433.5	Quench	Quench
487.1	Anello sede paraolio	Lipseal seat ring
471.2	Coperchio flangiato tenuta meccanica	Seal chamber cover flange
900.3	Prigioniero con dado	Stud with nut
903.5	Tappo	Plug

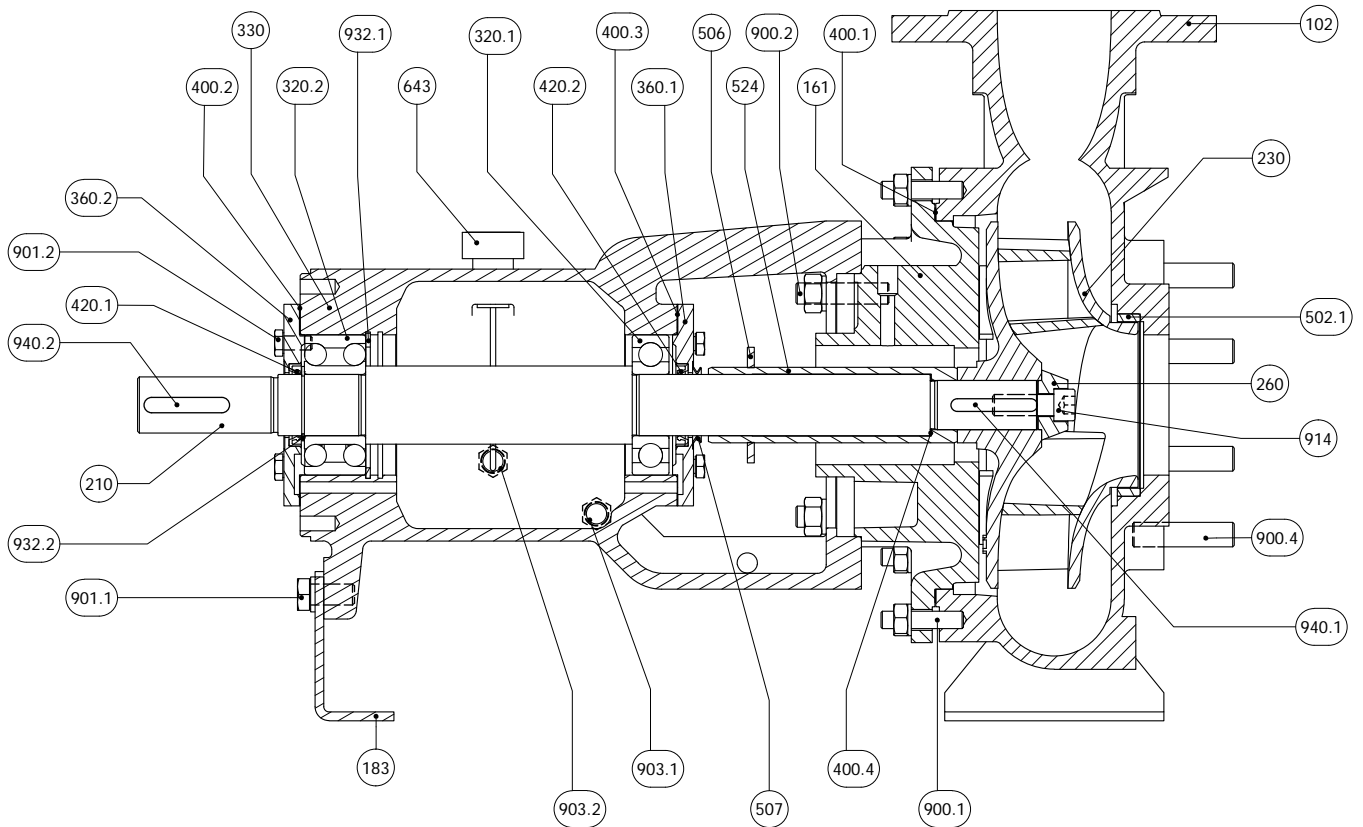

N.	Descrizione	Description
102	Corpo	Casing
161	Coperchio del corpo	Casing cover
183	Piede di appoggio	Support foot
210	Albero	Shaft
230	Girante	Impeller
260	Ogiva girante	Impeller hub
320.1	Cuscinetto a sfere L.O.C.	Ball bearing N.D.S.
320.2	Cuscinetto a sfere L.C.	Ball bearing D.S.
330	Supporto	Bearing housing
360.1	Coperchio cuscinetto L.O.C.	Bearing cover N.D.S.
360.2	Coperchio cuscinetto L.C.	Bearing cover D.S.
400.1	Guarnizione del corpo	Casing gasket
400.2	Guarnizione coperchio cuscinetto L.C.	Bearing cover gasket D.S.
400.3	Guarnizione coperchio cuscinetto L.O.C.	Bearing cover gasket N.D.S.
400.4	Guarnizione camicia	Sleeve gasket
420.1	Anello di tenuta L.C.	Bearing cover seal D.S.

N.	Descrizione	Description
420.2	Anello di tenuta L.O.C.	Bearing cover seal N.D.S.
502.1	Anello usura	Wear ring
506	Anello paraspruzzi	Deflector
507	V. Ring	V. Ring
524	Camicia albero	Shaft sleeve
643	Tappo di sfiato con astina	Oil dipstick
900.1	Prigioniero con dado	Stud with nut
900.2	Prigioniero con dado	Stud with nut
900.4	Prigioniero con dado	Stud with nut
901.1	Vite T.E.	Hex head screw
901.2	Vite T.E.	Hex head screw
903.1	Tappo scarico olio	Oil drain plug
903.2	Tappo oliatore	Constant level oiler plug
914	Vite ogivale	Screw
932.1	Anello di sicurezza (seeger) foro	Hole circlip
932.2	Anello di sicurezza (seeger) albero	Shaft circlip
940.1	Linguetta girante	Impeller key
940.2	Linguetta giunto	Coupling key

Grandezze | Size: 80-31, 125-31, 125-40, 150-31

Gruppo 3 | Group 3

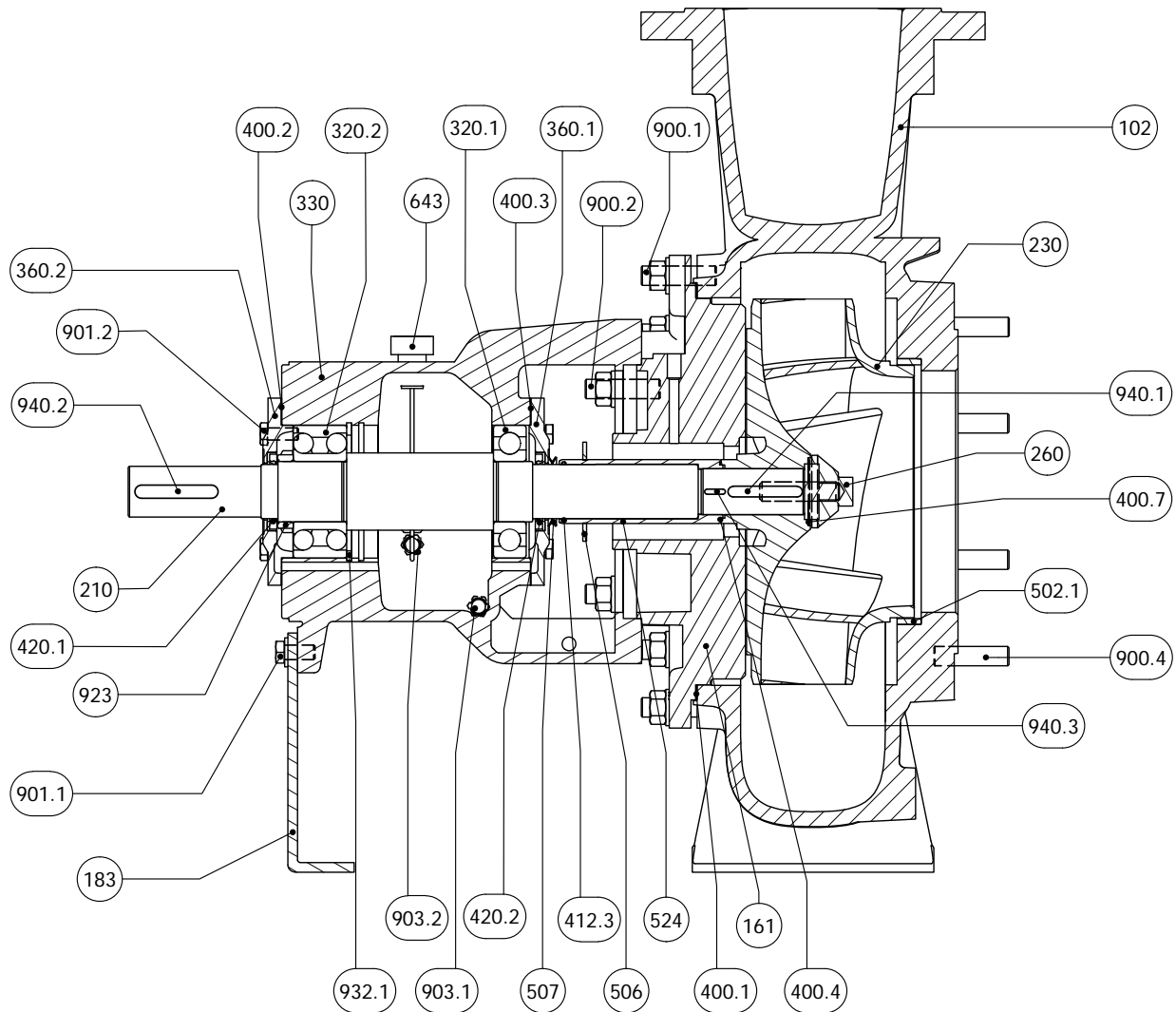

N.	Descrizione	Description
102	Corpo	Casing
161	Coperchio del corpo	Casing cover
183	Piede di appoggio	Support foot
210	Albero	Shaft
230	Girante	Impeller
260	Ogiva girante	Impeller hub
320.1	Cuscinetto a sfere L.O.C.	Ball bearing N.D.S.
320.2	Cuscinetto a sfere L.C.	Ball bearing D.S.
330	Supporto	Bearing housing
360.1	Coperchio cuscinetto L.O.C.	Bearing cover N.D.S.
360.2	Coperchio cuscinetto L.C.	Bearing cover D.S.
400.1	Guarnizione del corpo	Casing gasket
400.2	Guarnizione coperchio cuscinetto L.C.	Bearing cover gasket D.S.
400.3	Guarnizione coperchio cuscinetto L.O.C.	Bearing cover gasket N.D.S.
400.4	Guarnizione camicia	Sleeve gasket
400.7	Guarnizione ogiva	Hub gasket
412.3	O-ring camicia	O-ring shaft sleeve

N.	Descrizione	Description
420.1	Anello di tenuta L.C.	Bearing cover seal D.S.
420.2	Anello di tenuta L.O.C.	Bearing cover seal N.D.S.
502.1	Anello usura	Wear ring
506	Anello paraspruzzi	Deflector
507	V. Ring	V. Ring
524	Camicia albero	Shaft sleeve
643	Tappo di sfiato con astina	Oil dipstick
900.1	Prigioniero con dado	Stud with nut
900.2	Prigioniero con dado	Stud with nut
900.4	Prigioniero con dado	Stud with nut
901.1	Vite T.E.	Hex head screw
901.2	Vite T.E.	Hex head screw
903.1	Tappo scarico olio	Oil drain plug
903.2	Tappo oliatore	Constant level oiler plug
923	Ghiera cuscinetto	Bearing nut
932.1	Anello di sicurezza (seeger) foro	Hole circlip
940.1	Linguetta girante	Impeller key
940.2	Linguetta giunto	Coupling key
940.3	Linguetta camicia	Sleeve key

Sezione con nomenclatura asse nudo  
 Bare shaft sectional view and nomenclature

Girante multi-canale chiusa  
 Closed multi-channel impeller

Grandezze | Size: 150-35, 200-35, 200-45, 250-35, 250-45, 300-45, 300-46

Gruppo 4 e 5 | Group 4 and 5

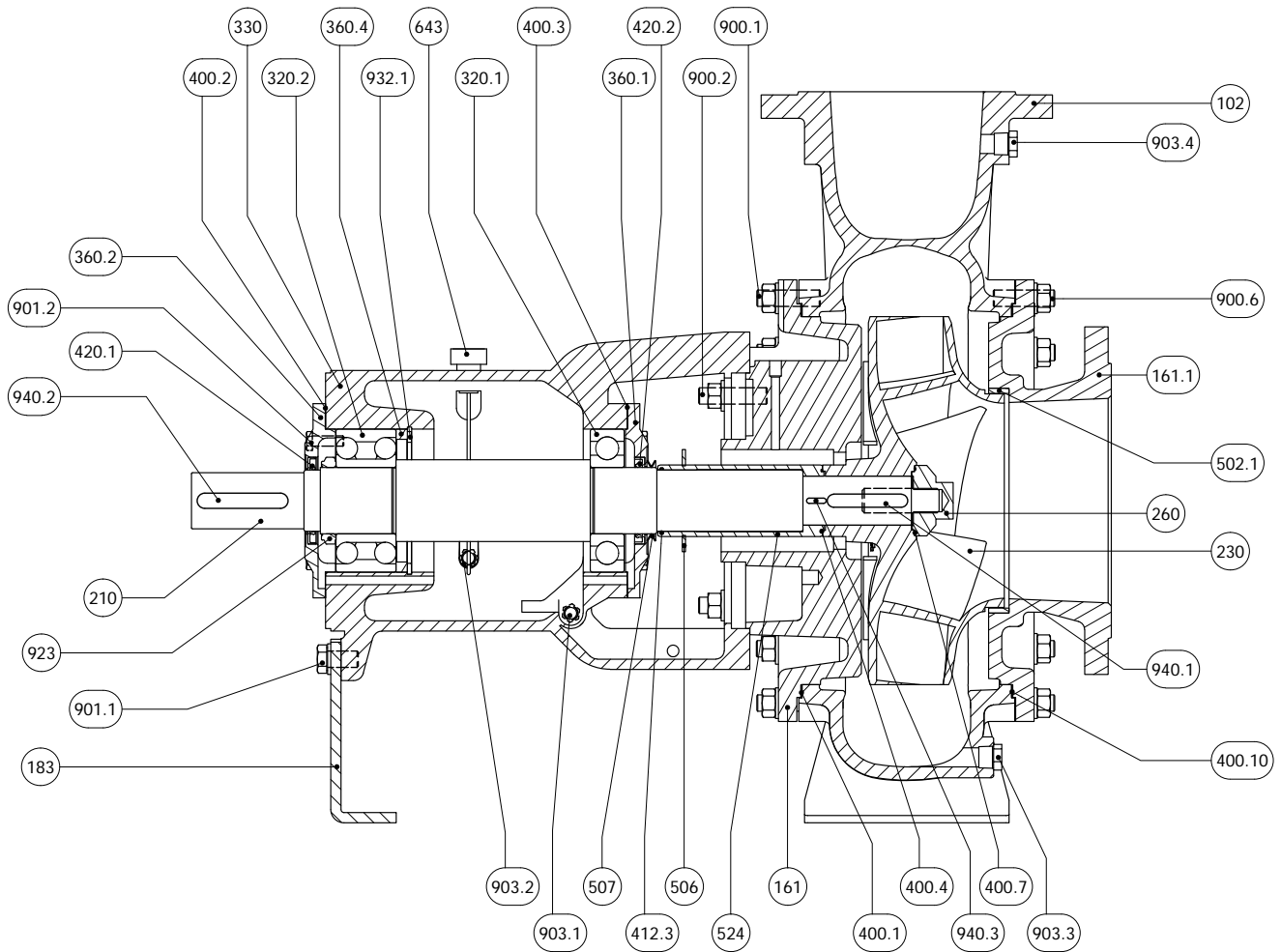

N.	Descrizione	Description
102	Corpo	Casing
161	Coperchio del corpo	Casing cover
161.1	Coperchio aspirante	Flange casing cover
183	Piede di appoggio	Support foot
210	Albero	Shaft
230	Girante	Impeller
260	Ogiva girante	Impeller hub
320.1	Cuscinetto a sfere L.O.C.	Ball bearing N.D.S.
320.2	Cuscinetto a sfere L.C.	Ball bearing D.S.
330	Supporto	Bearing housing
360.1	Coperchio cuscinetto L.O.C.	Bearing cover N.D.S.
360.2	Coperchio cuscinetto L.C.	Bearing cover D.S.
360.4	Distanziale cuscinetto	Ball bearing spacer
400.1	Guarnizione del corpo	Casing gasket
400.2	Guarnizione coperchio cuscinetto l.c.	Bearing cover gasket D.S.
400.3	Guarnizione coperchio cuscinetto l.o.c.	Bearing cover gasket N.D.S.
400.4	Guarnizione camicia	Sleeve gasket
400.7	Guarnizione ogiva	Hub gasket
400.10	Guarnizione coperchio aspirante	Flange casing cover gasket
412.3	O-ring camicia	O-ring shaft sleeve

N.	Descrizione	Description
420.1	Anello di tenuta L.C.	Bearing cover seal D.S.
420.2	Anello di tenuta L.O.C.	Bearing cover seal N.D.S.
502.1	Anello usura	Wear ring
506	Anello paraspruzzi	Deflector
507	V. Ring	V. Ring
524	Camicia albero	Shaft sleeve
643	Tappo di sfiato con astina	Oil dipstick
900.1	Prigioniero con dado	Stud with nut
900.2	Prigioniero con dado	Stud with nut
900.6	Prigioniero con dado	Stud with nut
901.1	Vite T.E.	Hex head screw
901.2	Vite T.E.	Hex head screw
903.1	Tappo scarico olio	Oil drain plug
903.2	Tappo oliatore	Constant level oiler plug
903.3	Tappo drenaggio	Drain plug
903.4	Tappo manometro	Manometer plug
923	Ghiera cuscinetto	Bearing nut
932.1	Anello di sicurezza (seeger) foro	Hole circlip
940.1	Linguetta girante	Impeller key
940.2	Linguetta giunto	Coupling key
940.3	Linguetta camicia	Sleeve key

Grandezze | Size: 400-60

Gruppo 6 | Group 6

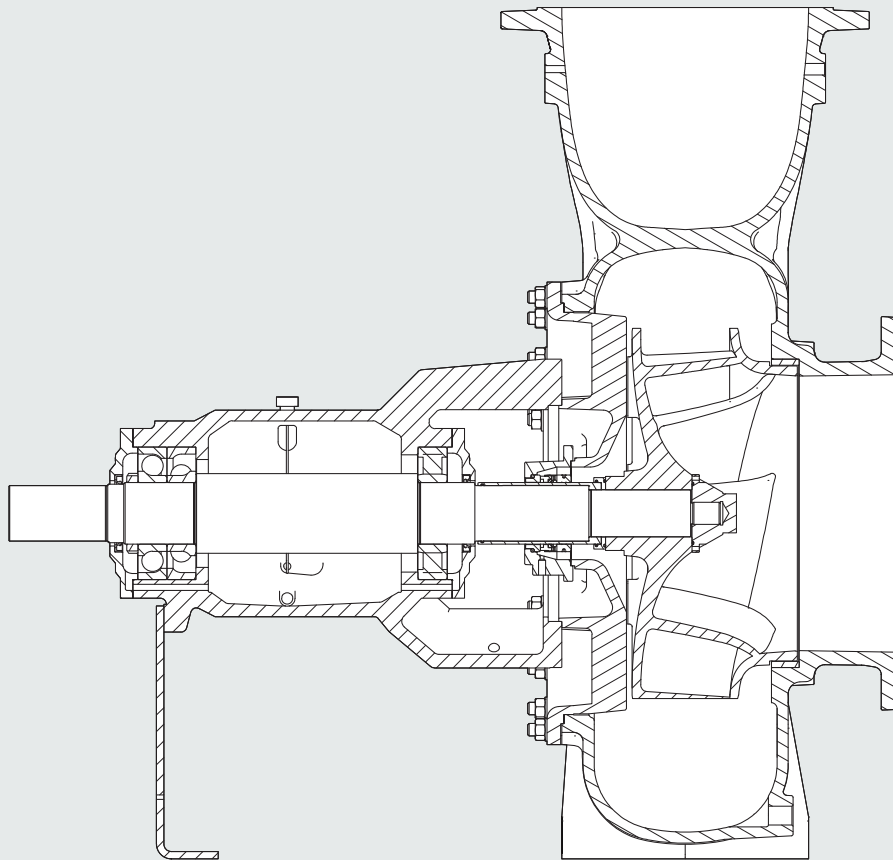

**PRELIMINARY DATA**

more information on [sr.pumps.com](http://sr.pumps.com)

Sezione con nomenclatura lanterna  
Lantern bracket sectional view and nomenclature

Girante multi-canale chiusa  
Closed multi-channel impeller

Grandezze | Size: 65-20, 80-20, 80-25, 100-25, 125-25

Gruppo 2 | Group 2

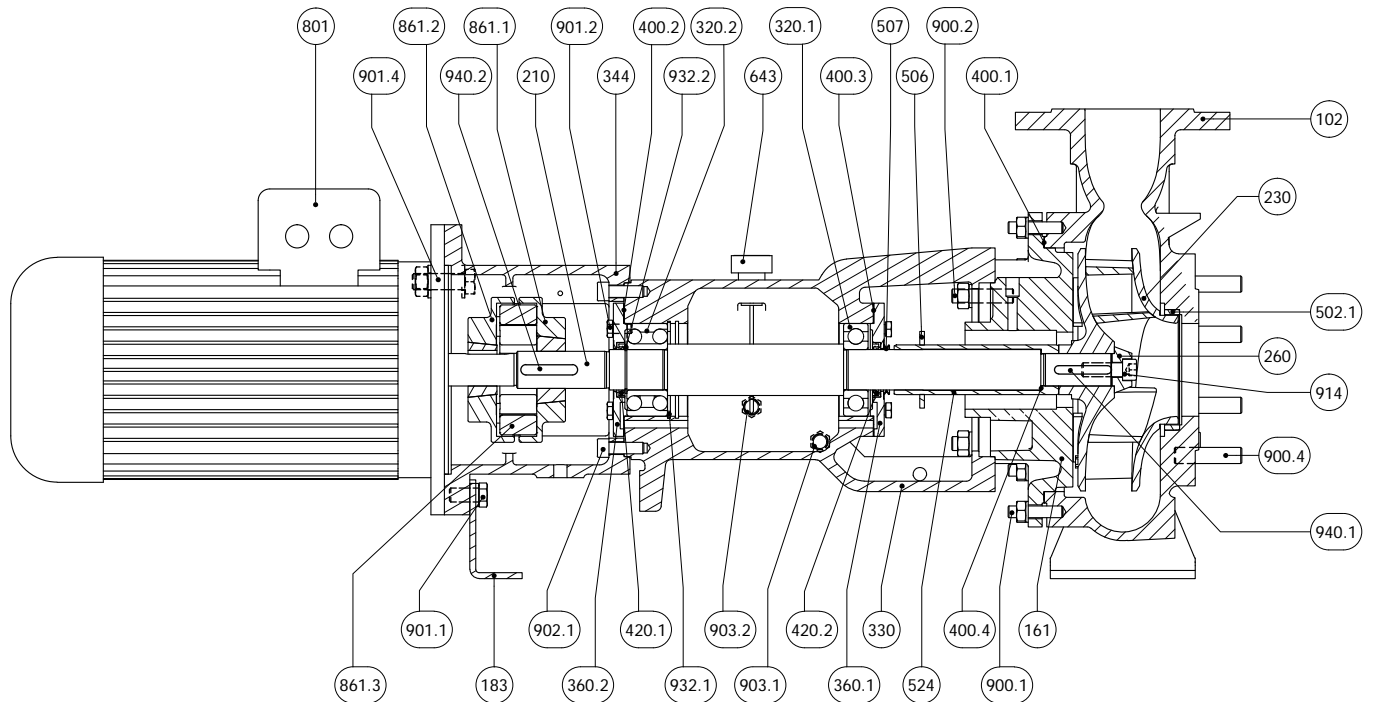

N.	Descrizione	Description
102	Corpo	Casing
161	Coperchio del corpo	Casing cover
183	Piede di appoggio	Support foot
210	Albero	Shaft
230	Girante	Impeller
260	Ogiva girante	Impeller hub
320.1	Cuscinetto a sfere L.O.C.	Ball bearing N.D.S.
320.2	Cuscinetto a sfere L.C.	Ball bearing D.S.
330	Supporto	Bearing housing
344	Lanterna motore	Lantern bracket
360.1	Coperchio cuscinetto L.O.C.	Bearing cover N.D.S.
360.2	Coperchio cuscinetto L.C.	Bearing cover D.S.
400.1	Guarnizione del corpo	Casing gasket
400.2	Guarnizione coperchio cuscinetto L.C.	Bearing cover gasket L.C.
400.3	Guarnizione coperchio cuscinetto L.O.C.	Bearing cover gasket N.D.S.
400.4	Guarnizione camicia	Sleeve gasket
420.1	Anello di tenuta L.C.	Bearing cover seal D.S.
420.2	Anello di tenuta L.O.C.	Bearing cover seal N.D.S.
502.1	Anello usura	Wear ring
506	Anello paraspruzzi	Deflector

N.	Descrizione	Description
507	V. Ring	V. Ring
524	Camicia albero	Shaft sleeve
643	Tappo di sfiato con astina	Oil dipstick
801	Motore elettrico	Electric motor
861.1	Semi giunto lato pompa	Half coupling pump side
861.2	Semi giunto lato motore	Half coupling motor side
861.3	Elastomero giunto	Coupling Elastomer
900.1	Prigioniero con dado	Stud with nut
900.2	Prigioniero con dado	Stud with nut
900.4	Prigioniero con dado	Stud with nut
901.1	Vite T.E.	Hex head screw
901.2	Vite T.E.	Hex head screw
901.4	Vite T.E.	Hex head screw
902.1	Vite T.C.E.I.	Socket hex head screw
903.1	Tappo scarico olio	Oil drain plug
903.2	Tappo oliatore	Constant level oiler plug
914	Vite ogivale	Screw
932.1	Anello di sicurezza (seeger) foro	Hole circlip
932.2	Anello di sicurezza (seeger) albero	Shaft circlip
940.1	Linguetta girante	Impeller key
940.2	Linguetta giunto	Coupling key

Sezione con nomenclatura lanterna  
Lantern bracket sectional view and nomenclature

Girante multi-canale chiusa  
Closed multi-channel impeller

Grandezze | Size: 80-31, 125-31, 125-40, 150-31

Gruppo 3 | Group 3

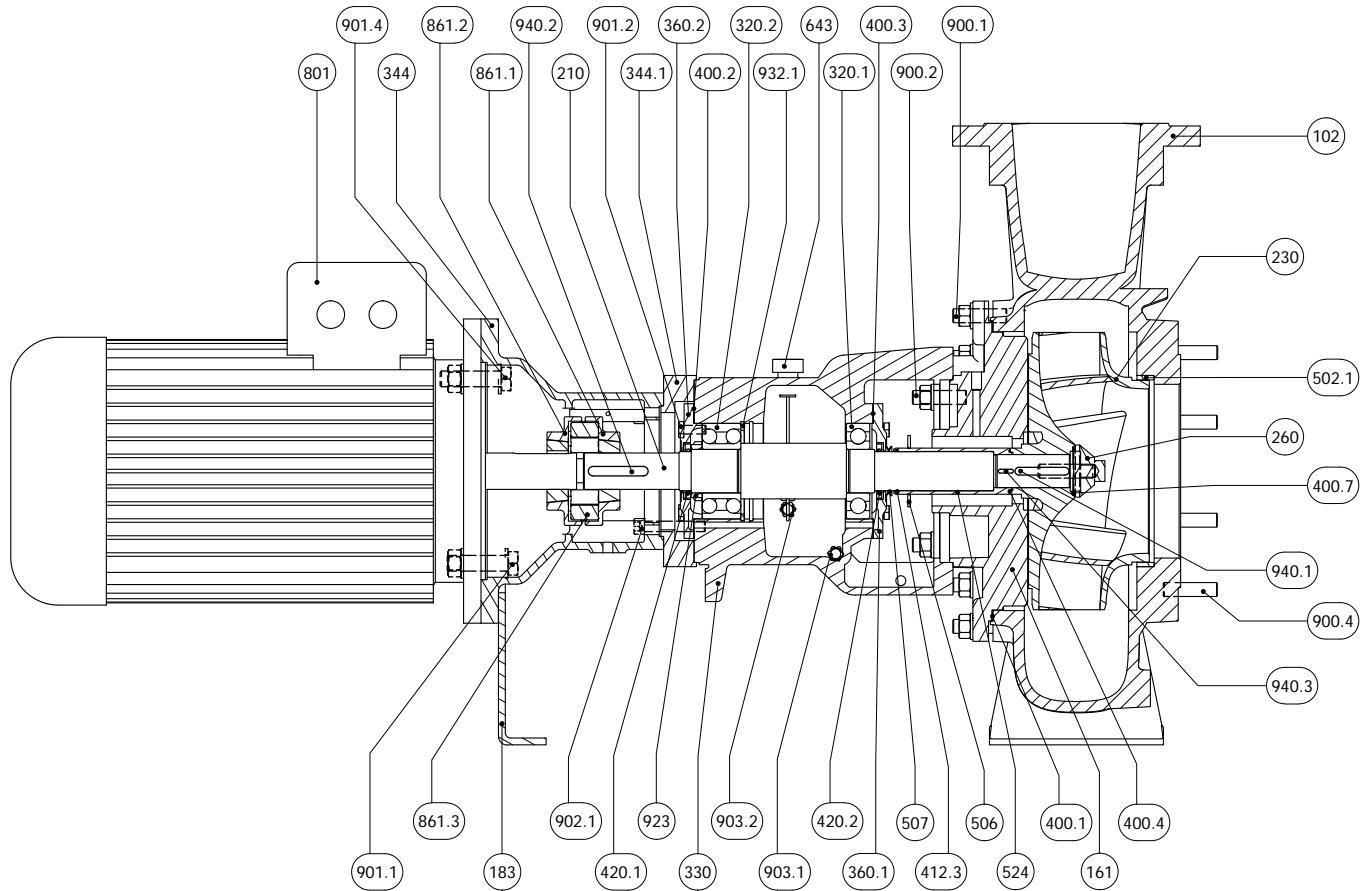

N.	Descrizione	Description
102	Corpo	Casing
161	Coperchio del corpo	Casing cover
183	Piede di appoggio	Support foot
210	Albero	Shaft
230	Girante	Impeller
260	Ogiva girante	Impeller hub
320.1	Cuscinetto a sfere L.O.C.	Ball bearing N.D.S.
320.2	Cuscinetto a sfere L.C.	Ball bearing D.S.
330	Supporto	Bearing housing
344	Lanterna motore	Lantern bracket
344.1	Flangia di riduzione	Reduction flange
360.1	Coperchio cuscinetto L.O.C.	Bearing cover N.D.S.
360.2	Coperchio cuscinetto L.C.	Bearing cover D.S.
400.1	Guarnizione del corpo	Casing gasket
400.2	Guarnizione coperchio cuscinetto L.C.	Bearing cover gasket L.C.
400.3	Guarnizione coperchio cuscinetto L.O.C.	Bearing cover gasket N.D.S.
400.4	Guarnizione camicia	Sleeve gasket
400.7	Guarnizione ogiva	Hub gasket
412.3	O-ring camicia	O-ring shaft sleeve
420.1	Anello di tenuta L.C.	Bearing cover seal D.S.
420.2	Anello di tenuta L.O.C.	Bearing cover seal N.D.S.

N.	Descrizione	Description
502.1	Anello usura	Wear ring
506	Anello paraspruzzi	Deflector
507	V. Ring	V. Ring
524	Camicia albero	Shaft sleeve
643	Tappo di sfiato con astina	Oil dipstick
801	Motore elettrico	Electric motor
861.1	Semi giunto lato pompa	Half coupling pump side
861.2	Semi giunto lato motore	Half coupling motor side
861.3	Elastomero giunto	Coupling Elastomer
900.1	Prigioniero con dado	Stud with nut
900.2	Prigioniero con dado	Stud with nut
900.4	Prigioniero con dado	Stud with nut
901.1	Vite T.E.	Hex head screw
901.2	Vite T.E.	Hex head screw
901.4	Vite T.E.	Hex head screw
902.1	Vite T.C.E.I.	Socket hex head screw
903.1	Tappo scarico olio	Oil drain plug
903.2	Tappo oliatore	Constant level oiler plug
923	Ghiera cuscinetto	Bearing nut
932.1	Anello di sicurezza (seeger) foro	Hole circlip
940.1	Linguetta girante	Impeller key
940.2	Linguetta giunto	Coupling key
940.3	Linguetta camicia	Sleeve key

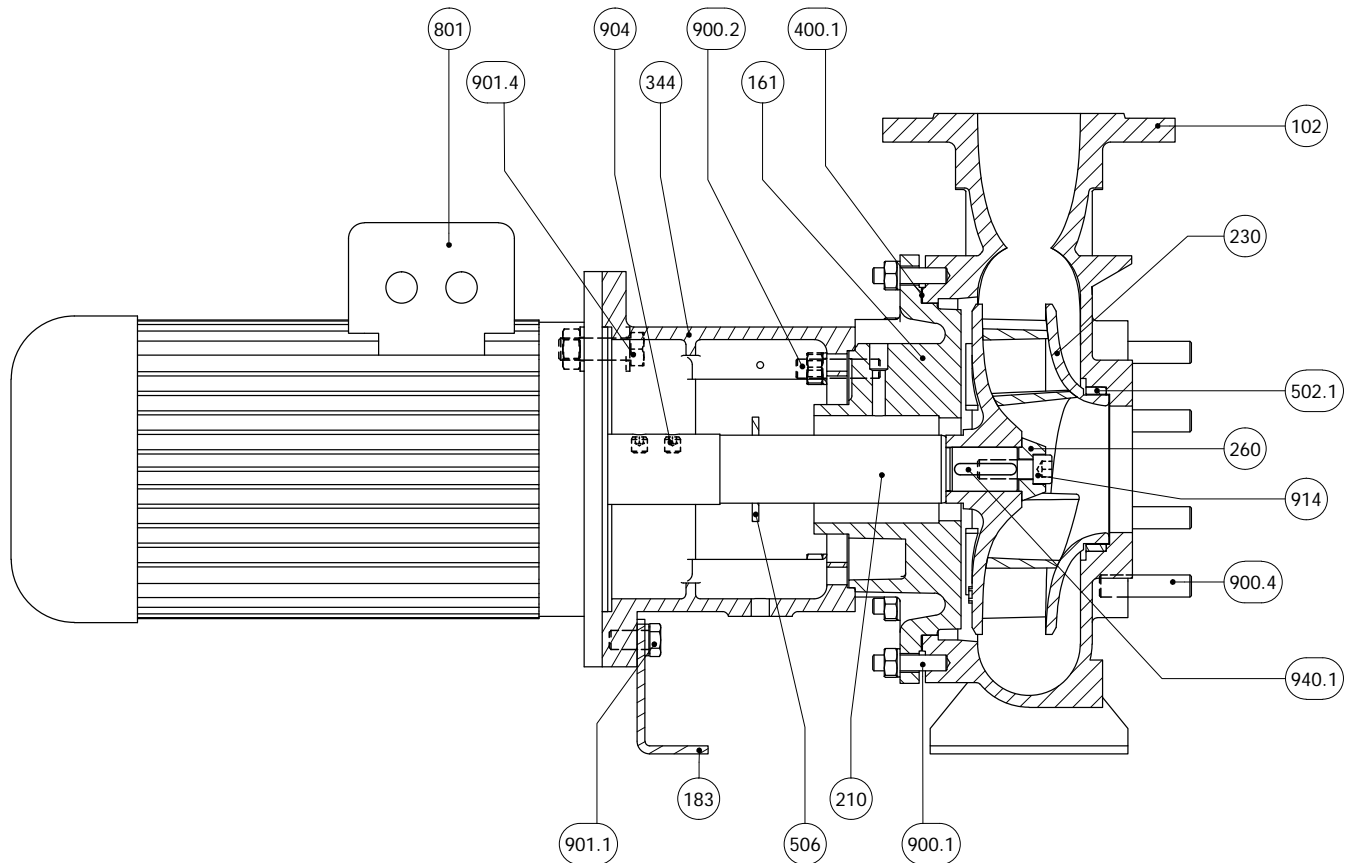

N.	Descrizione	Description
102	Corpo	Casing
161	Coperchio del corpo	Casing cover
183	Piede di appoggio	Support foot
210	Albero	Shaft
230	Girante	Impeller
260	Ogiva girante	Impeller hub
344	Lanterna motore	Lantern bracket
400.1	Guarnizione del corpo	Casing gasket
502.1	Anello usura	Wear ring
506	Anello paraspruzzi	Deflector

N.	Descrizione	Description
801	Motore elettrico	Electric motor
900.1	Prigioniero con dado	Stud with nut
900.2	Prigioniero con dado	Stud with nut
900.4	Prigioniero con dado	Stud with nut
901.1	Vite T.E.	Hex head screw
901.4	Vite T.E.	Hex head screw
904	Grano	Locking screw
914	Vite ogivale	Screw
940.1	Linguetta girante	Impeller key

Sezione con nomenclatura asse nudo  
 Bare shaft sectional view and nomenclature

Girante multi-canale aperta  
 Open multi-channel impeller

Grandezze | Size: 80-31, 125-31, 125-40

Gruppo 3 | Group 3

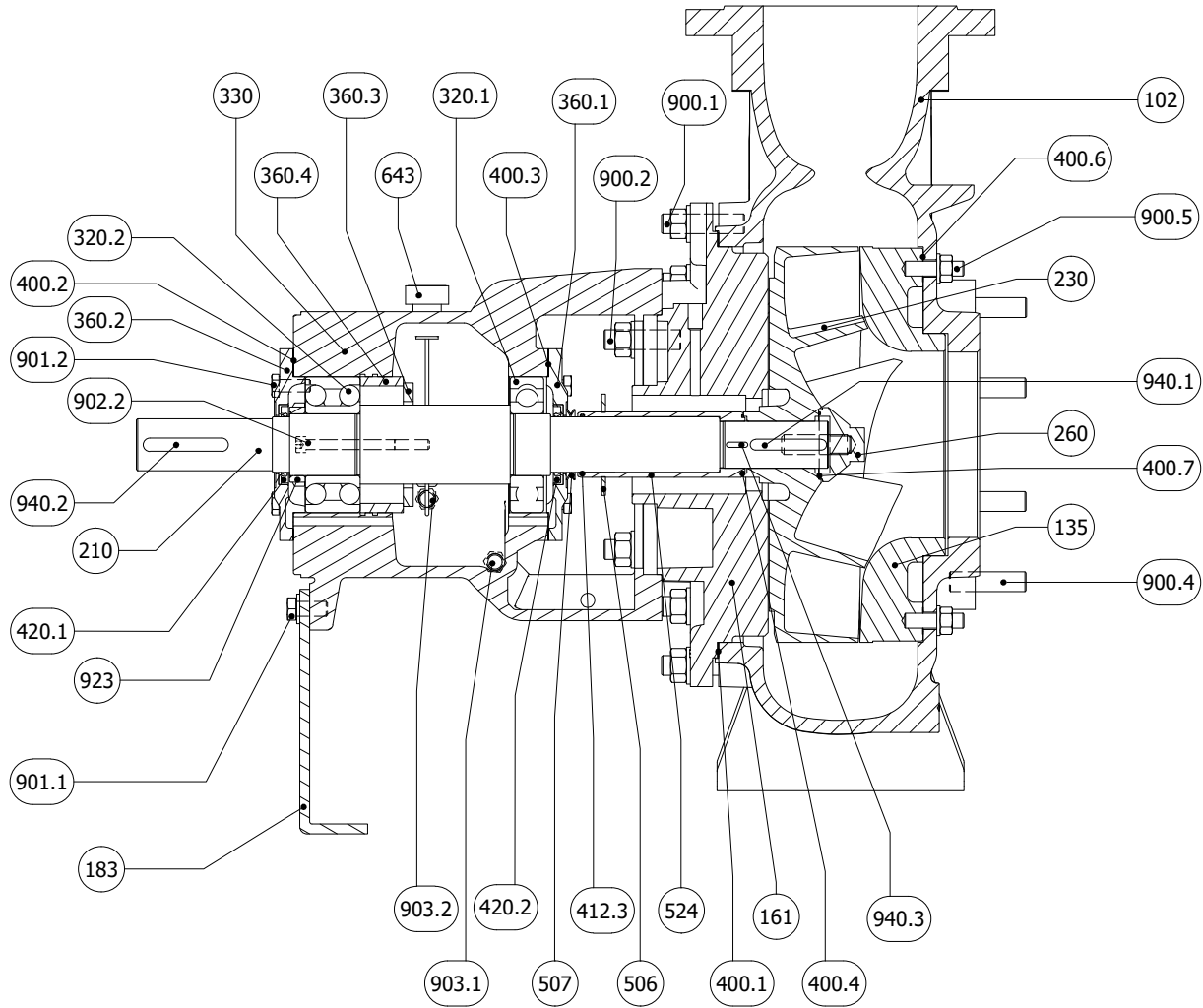

N.	Descrizione	Description
102	Corpo	Casing
135	Piastra di usura	Wear plate
161	Coperchio del corpo	Casing cover
183	Piede di appoggio	Support foot
210	Albero	Shaft
230	Girante	Impeller
260	Ogiva girante	Impeller hub
320.1	Cuscinetto a sfere L.O.C.	Ball bearing N.D.S.
320.2	Cuscinetto a sfere L.C.	Ball bearing D.S.
330	Supporto	Bearing housing
360.1	Coperchio cuscinetto L.O.C.	Bearing cover N.D.S.
360.2	Coperchio cuscinetto L.C.	Bearing cover D.S.
360.3	Staffa cuscinetto	Bearing bracket
360.4	Distanziale cuscinetto	Bearing Spacer
400.1	Guarnizione del corpo	Casing gasket
400.2	Guarnizione coperchio cuscinetto L.C.	Bearing cover gasket D.S.
400.3	Guarnizione coperchio cuscinetto L.O.C.	Bearing cover gasket N.D.S.
400.4	Guarnizione camicia	Sleeve gasket
400.6	Guarnizione piastra d'usura	Wear plate gasket
400.7	Guarnizione ogiva	Hub gasket

N.	Descrizione	Description
412.3	O-ring camicia	O-ring shaft sleeve
420.1	Anello di tenuta L.C.	Bearing cover seal D.S.
420.2	Anello di tenuta L.O.C.	Bearing cover seal N.D.S.
506	Anello paraspruzzi	Deflector
507	V. Ring	V. Ring
524	Camicia albero	Shaft sleeve
643	Tappo di sfiato con astina	Oil dipstick
900.1	Prigioniero con dado	Stud with nut
900.2	Prigioniero con dado	Stud with nut
900.4	Prigioniero con dado	Stud with nut
900.5	Prigioniero con dado	Stud with nut
901.1	Vite T.E.	Hex head screw
901.2	Vite T.E.	Hex head screw
902.2	Vite T.C.E.I.	Socket head screw
903.1	Tappo scarico olio	Oil drain plug
903.2	Tappo oliatore	Constant level oiler plug
923	Ghiera cuscinetto	Bearing nut
940.1	Linguetta girante	Impeller key
940.2	Linguetta giunto	Coupling key
940.3	Linguetta camicia	Sleeve key

Sezione con nomenclatura lanterna  
Lantern bracket sectional view and nomenclature

Girante multi-canale aperta  
Open multi-channel impeller

Grandezze | Size: 80-31, 125-31, 125-40

Gruppo 3 | Group 3

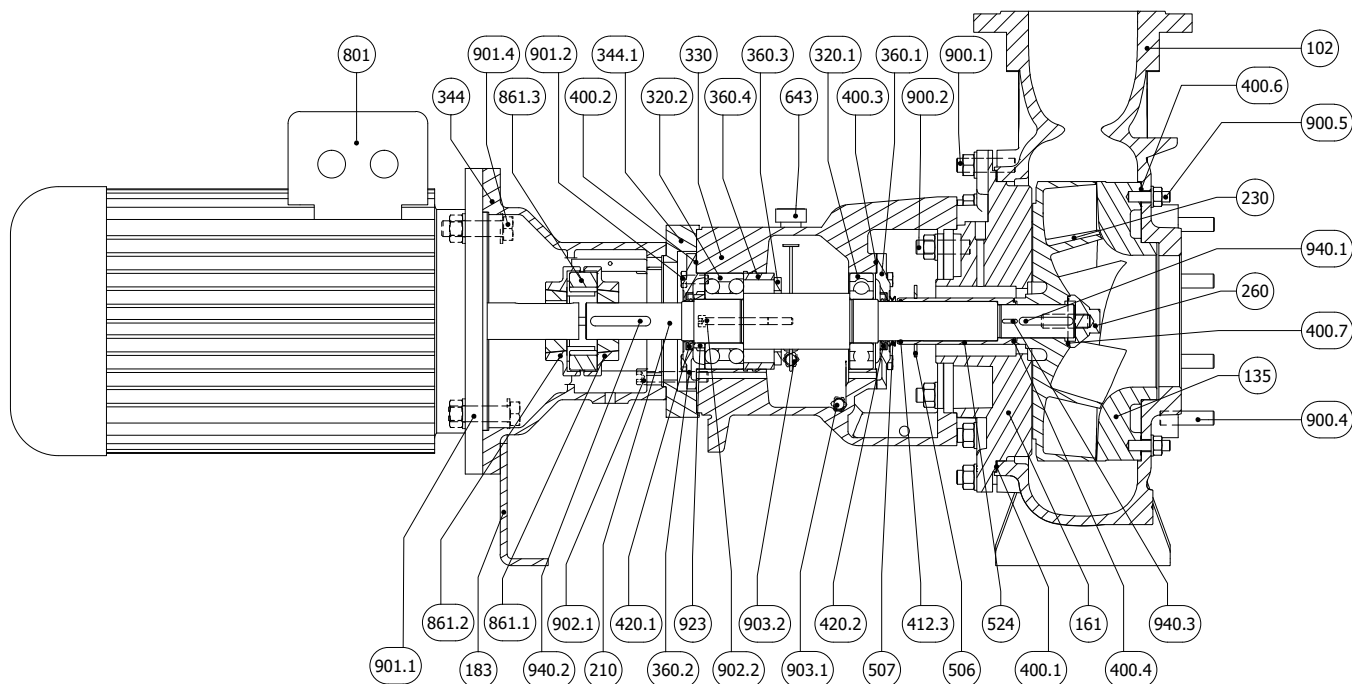

N.	Descrizione	Description
102	Corpo	Casing
135	Piastra di usura	Wear plate
161	Coperchio del corpo	Casing cover
183	Piede di appoggio	Support foot
210	Albero	Shaft
230	Girante	Impeller
260	Ogiva girante	Impeller hub
320.1	Cuscinetto a sfere L.O.C.	Ball bearing N.D.S.
320.2	Cuscinetto a sfere L.C.	Ball bearing D.S.
330	Supporto	Bearing housing
344	Lanterna motore	Lantern bracket
344.1	Flangia di riduzione	Reduction flange
360.1	Coperchio cuscinetto L.O.C.	Bearing cover N.D.S.
360.2	Coperchio cuscinetto L.C.	Bearing cover D.S.
360.3	Staffa cuscinetto	Bearing bracket
360.4	Distanziale Cuscinetto	Bearing spacer
400.1	Guarnizione del corpo	Casing gasket
400.2	Guarnizione coperchio cuscinetto L.C.	Bearing cover gasket D.S.
400.3	Guarnizione coperchio cuscinetto L.O.C.	Bearing cover gasket N.D.S.
400.4	Guarnizione camicia	Sleeve gasket
400.6	Guarnizione piastra d'usura	Wear plate gasket
400.7	Guarnizione ogiva	Hub gasket
420.1	Anello di tenuta L.C.	Bearing cover seal D.S.
420.2	Anello di tenuta L.O.C.	Bearing cover seal N.D.S.

N.	Descrizione	Description
412.3	O-ring camicia	O-ring shaft sleeve
506	Anello paraspruzzi	Deflector
507	V. Ring	V. Ring
524	Camicia albero	Shaft sleeve
643	Tappo di sfiato con astina	Oil dipstick
801	Motore elettrico	Electric motor
861.1	Semi giunto lato pompa	Half coupling pump side
861.2	Semi giunto lato motore	Half coupling motor side
861.3	Elastomero	Coupling Elastomer
900.1	Prigioniero con dado	Stud with nut
900.2	Prigioniero con dado	Stud with nut
900.4	Prigioniero con dado	Stud with nut
900.5	Prigioniero con dado	Stud with nut
901.1	Vite T.E.	Hex head screw
901.2	Vite T.E.	Hex head screw
901.4	Vite T.E.	Hex head screw
902.1	Vite T.C.E.I.	Socket head screw
902.2	Vite T.C.E.I.	Socket head screw
903.1	Tappo scarico olio	Oil drain plug
903.2	Tappo oliatore	Constant level oiler plug
923	Ghiera cuscinetto	Bearing nut
940.1	Linguetta girante	Impeller key
940.2	Linguetta giunto	Coupling key
940.3	Linguetta camicia	Sleeve key

Ingombri asse nudo  
Bare shaft overall dimensions

Girante multi-canale chiusa e aperta  
Closed and open multi-channel impeller

Grandezze | Size:  
65-20, 80-20, 80-25, 80-31, 100-25, 125-25, 125-31, 125-40, 150-31

Solo per grandezze | Only Size:  
150-35, 200-35, 200-45, 250-35, 250-45,  
300-45, 300-46, 400-60

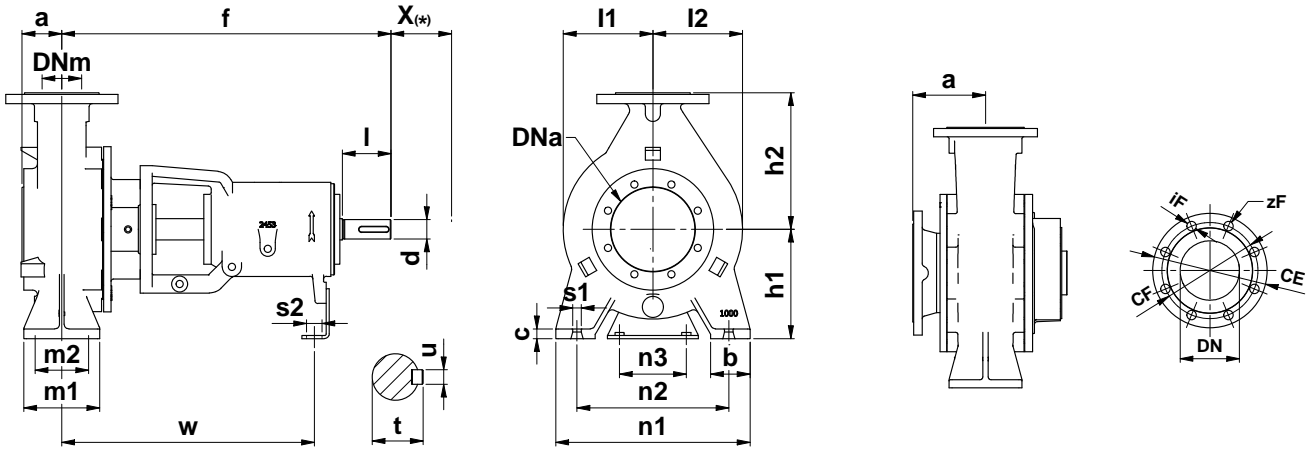

Dimensioni Flange  
Dimensions Flange EN1092-1/2 PN10

<b>DNa-DNm</b>	65	80	100	125	150	200	250	300	350	400	450
<b>CF</b>	145	160	180	210	240	295	350	400	430	515	565
<b>DE</b>	185	200	220	250	285	340	395	445	505	565	615
<b>iF</b>	18	18	18	18	22	23	23	23	23	26	26
<b>zF</b>	4	8	8	8	8	8	12	12	16	16	20

Pompa tipo Pump size	Gruppo Supporto Bearing Housing Group	Dimensioni Dimensions (mm)																				Peso Weight (kg)			
		Pompa Pump					Piedi Feet					Albero Shaft													
		DNa	DNm	a	f	h1	h2	b	c	m1	m2	n1	n2	n3	s1	s2	w	d	l	t	u		l1	l2	X(*)
65-20 <sup>(a)</sup>	GR2	80	65	66	522	180	225	65	16	125	95	320	250	110	14	14	396	32	80	35	10	151	151	140	62
80-20 <sup>(a)</sup>	GR2	100	80	68	530	180	250	65	16	125	95	345	280	110	14	14	404	32	80	35	10	159	159	140	66
80-25 <sup>(a)</sup>	GR2	100	80	75	535	225	280	70	18	160	120	395	315	110	18	14	409	32	80	35	10	176	176	140	86
80-31	GR3	100	80	90	557	250	315	80	18	160	120	400	315	110	18	14	397	42	110	45	12	205	227	140	134
100-25 <sup>(a)</sup>	GR2	125	100	90	545	225	280	80	18	160	120	400	315	110	18	14	419	32	80	35	10	183	216	140	103
125-25 <sup>(a)</sup>	GR2	150	125	112	557	250	355	80	18	160	120	400	315	110	18	14	432	32	80	35	10	208	254	140	128
125-31	GR3	150	125	112	569	280	355	100	20	200	150	500	400	110	23	14	410	42	110	54	12	223	256	140	158
125-40	GR3	150	125	110	563	315	400	100	20	200	150	500	400	110	24	15	399	42	110	45	12	254	288	140	190
150-31 <sup>(a)</sup>	GR3	200	150	120	566	315	400	100	22	200	150	550	450	110	24	15	404	42	110	45	12	243	316	200	183
150-35 <sup>(a)</sup>	GR4	200	150	200	700	315	400	100	22	200	150	550	450	140	24	19	526	55	110	59	16	257	300	200	280
200-35 <sup>(a)</sup>	GR4	250	200	250	712	355	450	100	22	200	150	550	450	140	24	19	538	55	110	59	16	275	352	200	326
200-45 <sup>(a)</sup>	GR5	250	200	250	932	380	500	100	22	200	150	550	450	140	24	19	695	75	150	80	20	315	382	250	525
250-35 <sup>(a)</sup>	GR4	300	250	300	727	355	500	130	26	260	190	690	560	140	28	19	553	55	110	59	16	286	371	200	380
250-45 <sup>(a)</sup>	GR5	300	250	300	944	425	560	130	28	260	190	690	560	140	28	19	707	75	150	80	20	349	450	250	615
300-45 <sup>(a)</sup>	GR5	350	300	300	959	450	600	180	30	360	250	800	670	140	28	19	722	75	150	80	20	377	485	250	707
300-46 <sup>(a)</sup>	GR5	350	300	300	959	450	600	180	30	360	250	800	670	140	28	19	722	75	150	80	20	377	485	250	708
400-60 <sup>(c)</sup>	GR6	450	400	350	1096	560	820	230	40	400	300	1100	900	240	33	21	795	90	160	95	25	466	615	250	1300

Quote e pesi possono variare senza preavviso  
Dimensions and weights can change without prior notice

(\*) Dimensione giunto Spaziatore  
(\*) Spacer coupling dimension

(\*) Solo per RB  
(\*) Only for RB type



Ingombri su base con giunto standard  
Overall dimensions on base with standard coupling

Girante multi-canale chiusa e aperta  
Closed and open multi-channel impeller

Pompa tipo Pump size	Grandezza motore Motor size	Base Base plate	Dimensioni Dimensions (mm)																	Peso Weight (kg) <sup>(*)</sup>		
			Dna	Dnm	a	f	h3	h2	L1	L2	L3	B2	B3	w	d	b	c1	c2	I1		I2	T <sub>(°)</sub>
65-20 <sup>(a)</sup>	90L	2	80	65	66	522	300	225	1000	170	660	400	360	75	19	30	0	90	151	151	933	122
	100L	2	80	65	66	522	300	225	1000	170	660	400	360	75	19	30	0	80	151	151	981	130
	112M	2	80	65	66	522	300	225	1000	170	660	400	360	75	19	30	0	68	151	151	985	137
	132S	2	80	65	66	522	300	225	1000	170	660	400	360	75	19	30	0	48	151	151	1057	150
	132M	2	80	65	66	522	300	225	1000	170	660	400	360	75	19	30	0	48	151	151	1094	161
	160M	3	80	65	66	522	300	225	1200	205	790	450	410	75	19	30	0	20	151	151	1203	244
	160L	3	80	65	66	522	300	225	1200	205	790	450	410	75	19	30	0	20	151	151	1247	257
	180M	3	80	65	66	522	300	225	1200	205	790	450	410	75	19	30	0	0	151	151	1223	302
	180L	3	80	65	66	522	300	225	1200	205	790	450	410	75	19	30	0	0	151	151	1301	322
	200L	5	80	65	66	522	320	225	1200	205	790	505	465	75	19	30	20	0	151	151	1354	386
	225S	6	80	65	66	522	390	225	1300	215	870	510	460	75	24	13	70	25	151	151	1389	432
	225M	6	80	65	66	522	390	225	1300	215	870	510	460	75	24	13	70	25	151	151	1414	474
80-20 <sup>(a)</sup>	100L	3	100	80	68	530	300	250	1200	205	790	450	410	75	19	30	0	80	159	159	991	144
	112M	3	100	80	68	530	300	250	1200	205	790	450	410	75	19	30	0	68	159	159	995	151
	132S	3	100	80	68	530	300	250	1200	205	790	450	410	75	19	30	0	48	159	159	1067	164
	132M	3	100	80	68	530	300	250	1200	205	790	450	410	75	19	30	0	48	159	159	1104	175
	160M	3	100	80	68	530	300	250	1200	205	790	450	410	75	19	30	0	20	159	159	1213	247
	160L	3	100	80	68	530	300	250	1200	205	790	450	410	75	19	30	0	20	159	159	1257	260
80-25 <sup>(a)</sup>	100L	5	100	80	75	535	345	280	1200	205	790	505	465	90	19	30	0	125	176	176	1003	165
	112M	5	100	80	75	535	345	280	1200	205	790	505	465	90	19	30	0	113	176	176	1007	172
	132S	5	100	80	75	535	345	280	1200	205	790	505	465	90	19	30	0	93	176	176	1079	185
	132M	5	100	80	75	535	345	280	1200	205	790	505	465	90	19	30	0	93	176	176	1116	196
	160M	5	100	80	75	535	345	280	1200	205	790	505	465	90	19	30	0	65	176	176	1225	268
	160L	5	100	80	75	535	345	280	1200	205	790	505	465	90	19	30	0	65	176	176	1269	281
	180M	5	100	80	75	535	345	280	1200	205	790	505	465	90	19	30	0	45	176	176	1245	326
	180L	5	100	80	75	535	345	280	1200	205	790	505	465	90	19	30	0	45	176	176	1323	346
	200L	6	100	80	75	535	390	280	1300	215	870	510	460	90	24	13	25	50	176	176	1376	411
80-31	132S	5	100	80	90	557	370	315	1200	205	790	505	465	90	19	30	0	118	205	227	1116	233
	132M	5	100	80	90	557	370	315	1200	205	790	505	465	90	19	30	0	118	205	227	1153	244
	160M	5	100	80	90	557	370	315	1200	205	790	505	465	90	19	30	0	90	205	227	1262	316
	160L	5	100	80	90	557	370	315	1200	205	790	505	465	90	19	30	0	90	205	227	1306	329
	180M	5	100	80	90	557	370	315	1200	205	790	505	465	90	19	30	0	70	205	227	1282	374
	180L	5	100	80	90	557	370	315	1200	205	790	505	465	90	19	30	0	70	205	227	1360	394
	200L	6	100	80	90	557	415	315	1300	215	870	510	460	90	24	13	25	75	205	227	1413	459
	225S	6	100	80	90	557	415	315	1300	215	870	510	460	90	24	13	25	50	205	227	1448	504
	225M	6	100	80	90	557	415	315	1300	215	870	510	460	90	24	13	25	50	205	227	1473	546
100-25 <sup>(a)</sup>	132S	5	125	100	90	545	345	280	1200	205	790	505	465	90	19	30	0	93	183	216	1104	203
	132M	5	125	100	90	545	345	280	1200	205	790	505	465	90	19	30	0	93	183	216	1141	214
	160M	5	125	100	90	545	345	280	1200	205	790	505	465	90	19	30	0	65	183	216	1250	286
	160L	5	125	100	90	545	345	280	1200	205	790	505	465	90	19	30	0	65	183	216	1294	299
	180M	5	125	100	90	545	345	280	1200	205	790	505	465	90	19	30	0	45	183	216	1270	344
	180L	5	125	100	90	545	345	280	1200	205	790	505	465	90	19	30	0	45	183	216	1348	364
200L	6	125	100	90	545	390	280	1300	215	870	510	460	90	24	13	25	50	183	216	1401	428	



Quote e pesi possono variare senza preavviso  
Dimensions and weights can change without prior notice

(\*) Lunghezza e peso possono variare in funzione della marca del motore  
(\*) Length and weight may vary, it depends by the motor brand

(\*) Solo per RB  
(\*) Only for RB type

Ingombri su base con giunto standard  
Overall dimensions on base with standard coupling

Girante multi-canale chiusa e aperta  
Closed and open multi-channel impeller

Pompa tipo Pump size	Grandezza motore Motor size	Base Base plate	Dimensioni Dimensions (mm)																			Peso Weight (kg) <sup>(*)</sup>
			Dna	Dnm	a	f	h3	h2	L1	L2	L3	B2	B3	w	d	b	c1	c2	l1	l2	T <sub>(c)</sub>	
125-25 <sup>(a)</sup>	132S	5	150	125	112	557	370	355	1200	205	790	505	465	90	19	30	0	118	208	254	1138	227
	132M	5	150	125	112	557	370	355	1200	205	790	505	465	90	19	30	0	118	208	254	1175	238
	160M	5	150	125	112	557	370	355	1200	205	790	505	465	90	19	30	0	90	208	254	1284	310
	160L	5	150	125	112	557	370	355	1200	205	790	505	465	90	19	30	0	90	208	254	1328	323
	180M	5	150	125	112	557	370	355	1200	205	790	505	465	90	19	30	0	70	208	254	1304	368
	180L	5	150	125	112	557	370	355	1200	205	790	505	465	90	19	30	0	70	208	254	1382	388
	200L	6	150	125	112	557	415	355	1300	215	870	510	460	90	24	13	25	75	208	254	1435	453
	225S	6	150	125	112	557	415	355	1300	215	870	510	460	90	24	13	25	50	208	254	1470	498
125-31	132M	6	150	125	112	569	445	355	1300	215	870	510	460	110	24	13	25	173	223	256	1187	270
	160M	6	150	125	112	569	445	355	1300	215	870	510	460	110	24	13	25	145	223	256	1296	342
	160L	6	150	125	112	569	445	355	1300	215	870	510	460	110	24	13	25	145	223	256	1340	355
	180M	6	150	125	112	569	445	355	1300	215	870	510	460	110	24	13	25	125	223	256	1316	400
	180L	6	150	125	112	569	445	355	1300	215	870	510	460	110	24	13	25	125	223	256	1394	420
	200L	6	150	125	112	569	445	355	1300	215	870	510	460	110	24	13	25	105	223	256	1447	483
	225S	7	150	125	112	569	445	355	1450	235	980	560	510	110	24	13	25	80	223	256	1482	535
	225M	7	150	125	112	569	445	355	1450	235	980	560	510	110	24	13	25	80	223	256	1507	577
	250M	7	150	125	112	569	445	355	1450	235	980	560	510	110	24	13	25	55	223	256	1569	694
125-40	132M	6	150	125	110	563	480	400	1300	215	870	510	460	110	24	13	25	208	254	288	1177	302
	160M	6	150	125	110	563	480	400	1300	215	870	510	460	110	24	13	25	180	254	288	1286	374
	160L	6	150	125	110	563	480	400	1300	215	870	510	460	110	24	13	25	180	254	288	1330	387
	180M	6	150	125	110	563	480	400	1300	215	870	510	460	110	24	13	25	160	254	288	1306	432
	180L	6	150	125	110	563	480	400	1300	215	870	510	460	110	24	13	25	160	254	288	1384	452
	200L	6	150	125	110	563	480	400	1300	215	870	510	460	110	24	13	25	140	254	288	1437	515
	225S	7	150	125	110	563	480	400	1450	235	980	560	510	110	24	13	25	115	254	288	1472	568
	225M	7	150	125	110	563	480	400	1450	235	980	560	510	110	24	13	25	115	254	288	1497	610
	250M	7	150	125	110	563	480	400	1450	235	980	560	510	110	24	13	25	90	254	288	1559	727
	280S	7	150	125	110	563	480	400	1450	235	980	560	510	110	24	13	25	60	254	288	1699	874
	280M	8	150	125	110	563	480	400	1590	235	1120	560	510	110	24	13	25	60	254	288	1749	930
	315S	10	150	125	110	563	520	400	2000	260	1480	710	660	110	26	15	25	25	254	288	1864	1183
150-31 <sup>(a)</sup>	132M	7	200	150	120	566	480	400	1450	235	980	560	510	110	24	13	25	208	243	316	1192	302
	160M	7	200	150	120	566	480	400	1450	235	980	560	510	110	24	13	25	180	243	316	1301	374
	160L	7	200	150	120	566	480	400	1450	235	980	560	510	110	24	13	25	180	243	316	1345	387
	180M	7	200	150	120	566	480	400	1450	235	980	560	510	110	24	13	25	160	243	316	1321	432
	180L	7	200	150	120	566	480	400	1450	235	980	560	510	110	24	13	25	160	243	316	1399	452
	200L	7	200	150	120	566	480	400	1450	235	980	560	510	110	24	13	25	140	243	316	1452	515
	225S	7	200	150	120	566	480	400	1450	235	980	560	510	110	24	13	25	115	243	316	1487	560
	225M	7	200	150	120	566	480	400	1450	235	980	560	510	110	24	13	25	115	243	316	1512	602
	250M	7	200	150	120	566	480	400	1450	235	980	560	510	110	24	13	25	90	243	316	1574	719
	280S	7	200	150	120	566	480	400	1450	235	980	560	510	110	24	13	25	60	243	316	1714	866

Quote e pesi possono variare senza preavviso  
Dimensions and weights can change without prior notice

(\*) Lunghezza e peso possono variare in funzione della marca del motore  
(\*) Length and weight may vary, it depends by the motor brand

(<sup>a</sup>) Solo per RB  
(<sup>a</sup>) Only for RB type

Ingombri su base con giunto standard  
Overall dimensions on base with standard coupling

Girante multi-canale chiusa e aperta  
Closed and open multi-channel impeller

Pompa tipo Pump size	Grandezza motore Motor size	Base Base plate	Dimensioni Dimensions (mm)																	Peso Weight (kg) <sup>(*)</sup>		
			Dna	Dnm	a	f	h3	h2	L1	L2	L3	B2	B3	w	d	b	c1	c2	l1		l2	T <sub>(c)</sub>
150-35 <sup>(a)</sup>	180M	7	200	150	200	700	480	400	1450	235	980	560	510	110	24	13	25	160	257	300	1535	529
	180L	7	200	150	200	700	480	400	1450	235	980	560	510	110	24	13	25	160	257	300	1613	549
	200L	7	200	150	200	700	480	400	1450	235	980	560	510	110	24	13	25	140	257	300	1666	612
	225S	8	200	150	200	700	480	400	1590	235	1120	560	510	110	24	13	25	115	257	300	1701	661
	225M	8	200	150	200	700	480	400	1590	235	1120	560	510	110	24	13	25	115	257	300	1726	703
	250M	8	200	150	200	700	480	400	1590	235	1120	560	510	110	24	13	25	90	257	300	1788	820
	280S	8	200	150	200	700	480	400	1590	235	1120	560	510	110	24	13	25	60	257	300	1928	967
	280M	9	200	150	200	700	520	400	1900	260	1380	610	560	110	26	15	25	60	257	300	1978	1057
	315S	10	200	150	200	700	520	400	2000	260	1480	710	660	110	26	15	25	25	257	300	2093	1273
	315M	10	200	150	200	700	520	400	2000	260	1480	710	660	110	26	15	25	25	257	300	2231	1528
200-35 <sup>(a)</sup>	160L	7	250	200	250	712	520	450	1450	235	980	560	510	110	24	13	25	220	275	352	1621	530
	180L	7	250	200	250	712	520	450	1450	235	980	560	510	110	24	13	25	200	275	352	1675	595
	200L	7	250	200	250	712	520	450	1450	235	980	560	510	110	24	13	25	180	275	352	1728	658
	225S	8	250	200	250	712	520	450	1590	235	1120	560	510	110	24	13	25	155	275	352	1763	707
	225M	8	250	200	250	712	520	450	1590	235	1120	560	510	110	24	13	25	155	275	352	1788	749
	250M	8	250	200	250	712	520	450	1590	235	1120	560	510	110	24	13	25	130	275	352	1850	866
	280S	8	250	200	250	712	520	450	1590	235	1120	560	510	110	24	13	25	100	275	352	1990	1013
	280M	9	250	200	250	712	560	450	1900	260	1380	610	560	110	26	15	25	100	275	352	2040	1103
	315S	10	250	200	250	712	560	450	2000	260	1480	710	660	110	26	15	25	65	275	352	2155	1318
	315M	10	250	200	250	712	560	450	2000	260	1480	710	660	110	26	15	25	65	275	352	2293	1573
200-45 <sup>(a)</sup>	200L	9	250	200	250	932	585	500	1900	260	1380	610	560	110	26	15	25	205	315	382	1948	898
	225S	9	250	200	250	932	585	500	1900	260	1380	610	560	110	26	15	25	180	315	382	1983	943
	225M	9	250	200	250	932	585	500	1900	260	1380	610	560	110	26	15	25	180	315	382	2008	985
	250M	9	250	200	250	932	585	500	1900	260	1380	610	560	110	26	15	25	155	315	382	2070	1102
	280S	9	250	200	250	932	585	500	1900	260	1380	610	560	110	26	15	25	125	315	382	2210	1249
	280M	9	250	200	250	932	585	500	1900	260	1380	610	560	110	26	15	25	125	315	382	2260	1302
	315S	10	250	200	250	932	585	500	2000	260	1480	710	660	110	26	15	25	90	315	382	2375	1518
	315M	10	250	200	250	932	585	500	2000	260	1480	710	660	110	26	15	25	90	315	382	2513	1773
250-35 <sup>(a)</sup>	180L	10	300	250	300	727	560	500	2000	260	1480	710	660	140	26	15	25	200	286	371	1740	703
	200L	10	300	250	300	727	560	500	2000	260	1480	710	660	140	26	15	25	180	286	371	1793	766
	225S	10	300	250	300	727	560	500	2000	260	1480	710	660	140	26	15	25	155	286	371	1828	811
	225M	10	300	250	300	727	560	500	2000	260	1480	710	660	140	26	15	25	155	286	371	1853	853
	250M	10	300	250	300	727	560	500	2000	260	1480	710	660	140	26	15	25	130	286	371	1915	970
	280S	10	300	250	300	727	560	500	2000	260	1480	710	660	140	26	15	25	100	286	371	2055	1117
	280M	10	300	250	300	727	560	500	2000	260	1480	710	660	140	26	15	25	100	286	371	2105	1170
	315S	10	300	250	300	727	560	500	2000	260	1480	710	660	140	26	15	25	65	286	371	2220	1372
	315M	10	300	250	300	727	560	500	2000	260	1480	710	660	140	26	15	25	65	286	371	2358	1627
	250-45 <sup>(a)</sup>	225M	10	300	250	300	944	630	560	2000	260	1480	710	660	140	26	15	25	225	349	450	2070
250M		10	300	250	300	944	630	560	2000	260	1480	710	660	140	26	15	25	200	349	450	2132	1206
280S		10	300	250	300	944	630	560	2000	260	1480	710	660	140	26	15	25	170	349	450	2272	1353
280M		10	300	250	300	944	630	560	2000	260	1480	710	660	140	26	15	25	170	349	450	2322	1406
315S		10	300	250	300	944	630	560	2000	260	1480	710	660	140	26	15	25	135	349	450	2437	1608
315M		10	300	250	300	944	630	560	2000	260	1480	710	660	140	26	15	25	135	349	450	2575	1863
315L		11	300	250	300	944	670	560	2300	350	1600	820	750	140	30	18	25	135	349	450	2575	1988
355L		11	300	250	300	944	670	560	2300	350	1600	820	750	140	30	18	25	95	349	450	2808	2667



Quote e pesi possono variare senza preavviso  
Dimensions and weights can change without prior notice

(\*) Lunghezza e peso possono variare in funzione della marca del motore  
(\*) Length and weight may vary, it depends by the motor brand

(\*) Solo per RB  
(\*) Only for RB type

Ingombri su base con giunto standard  
Overall dimensions on base with standard coupling

Girante multi-canale chiusa e aperta  
Closed and open multi-channel impeller

Pompa tipo Pump size	Grandezza motore Motor size	Base Base plate	Dimensioni Dimensions (mm)																			Peso Weight (kg) <sup>(*)</sup>
			Dna	Dnm	a	f	h3	h2	L1	L2	L3	B2	B3	w	d	b	c1	c2	l1	l2	T <sub>(*)</sub>	
300-45 <sup>(*)</sup>	250M	11	350	300	300	959	695	600	2300	350	1600	820	750	190	30	18	25	225	377	485	2147	1366
	280S	11	350	300	300	959	695	600	2300	350	1600	820	750	190	30	18	25	195	377	485	2287	1513
	280M	11	350	300	300	959	695	600	2300	350	1600	820	750	190	30	18	25	195	377	485	2337	1566
	315S	11	350	300	300	959	695	600	2300	350	1600	820	750	190	30	18	25	160	377	485	2452	1768
	315M	11	350	300	300	959	695	600	2300	350	1600	820	750	190	30	18	25	160	377	485	2590	2023
	315L	11	350	300	300	959	695	600	2300	350	1600	820	750	190	30	18	25	160	377	485	2590	2078
	355L	11	350	300	300	959	695	600	2300	350	1600	820	750	190	30	18	25	120	377	485	2823	2758
300-46 <sup>(*)</sup>	250M	11	350	300	300	959	695	600	2300	350	1600	820	750	190	30	18	25	225	377	485	2147	1366
	280S	11	350	300	300	959	695	600	2300	350	1600	820	750	190	30	18	25	195	377	485	2287	1513
	280M	11	350	300	300	959	695	600	2300	350	1600	820	750	190	30	18	25	195	377	485	2337	1566
	315S	11	350	300	300	959	695	600	2300	350	1600	820	750	190	30	18	25	160	377	485	2452	1768
	315M	11	350	300	300	959	695	600	2300	350	1600	820	750	190	30	18	25	160	377	485	2590	2023
	315L	11	350	300	300	959	695	600	2300	350	1600	820	750	190	30	18	25	160	377	485	2590	2078
	355L	11	350	300	300	959	695	600	2300	350	1600	820	750	190	30	18	25	120	377	485	2823	2758
400-60 <sup>(*)</sup>	315L	13	450	400	350	1096	835	820	3100	600	1900	1170	1100	250	24	18	35	280	466	615	3005	4150
	355L	13	450	400	350	1096	835	820	3100	600	1900	1170	1100	250	24	18	35	240	466	615	3130	4350

Quote e pesi possono variare senza preavviso  
Dimensions and weights can change without prior notice

(\*) Lunghezza e peso possono variare in funzione della marca del motore  
(\*) Length and weight may vary, it depends by the motor brand

(\*) Solo per RB  
(\*) Only for RB type



Ingombri su base con giunto spaziatore  
Overall dimensions on base with spacer coupling

Girante multi-canale chiusa e aperta  
Closed and open multi-channel impeller

Pompa tipo Pump size	Grandezza motore Motor size	Base Base plate	Dimensioni Dimensions (mm)																			Peso Weight (kg) <sup>(*)</sup>
			Dna	Dnm	a	f	h3	h2	L1	L2	L3	B2	B3	w	d	b	c1	c2	l1	l2	T <sub>(1)</sub>	
65-20 <sup>(a)</sup>	90L	2	80	65	66	522	300	225	1000	170	660	400	360	75	19	30	0	90	151	151	1073	122
	100L	3	80	65	66	522	300	225	1200	205	790	450	410	75	19	30	0	80	151	151	1121	141
	112M	3	80	65	66	522	300	225	1200	205	790	450	410	75	19	30	0	68	151	151	1125	148
	132S	3	80	65	66	522	300	225	1200	205	790	450	410	75	19	30	0	48	151	151	1197	161
	132M	3	80	65	66	522	300	225	1200	205	790	450	410	75	19	30	0	48	151	151	1234	172
	160M	4	80	65	66	522	300	225	1500	245	1010	480	440	75	19	30	0	20	151	151	1343	254
	160L	4	80	65	66	522	300	225	1500	245	1010	480	440	75	19	30	0	20	151	151	1387	267
	180M	4	80	65	66	522	300	225	1500	245	1010	480	440	75	19	30	0	0	151	151	1363	312
	180L	4	80	65	66	522	300	225	1500	245	1010	480	440	75	19	30	0	0	151	151	1441	332
	200L	7	80	65	66	522	365	225	1450	235	980	560	510	75	24	13	45	25	151	151	1494	394
	225S	7	80	65	66	522	390	225	1450	235	980	560	510	75	24	13	70	25	151	151	1529	439
	225M	7	80	65	66	522	390	225	1450	235	980	560	510	75	24	13	70	25	151	151	1554	481
80-20 <sup>(a)</sup>	100L	3	100	80	68	530	300	250	1200	205	790	450	410	75	19	30	0	80	159	159	1131	144
	112M	3	100	80	68	530	300	250	1200	205	790	450	410	75	19	30	0	68	159	159	1135	151
	132S	3	100	80	68	530	300	250	1200	205	790	450	410	75	19	30	0	48	159	159	1207	164
	132M	3	100	80	68	530	300	250	1200	205	790	450	410	75	19	30	0	48	159	159	1244	175
	160M	4	100	80	68	530	300	250	1500	245	1010	480	440	75	19	30	0	20	159	159	1353	257
	160L	4	100	80	68	530	300	250	1500	245	1010	480	440	75	19	30	0	20	159	159	1397	270
80-25 <sup>(a)</sup>	100L	5	100	80	75	535	345	280	1200	205	790	505	465	90	19	30	0	125	176	176	1143	165
	112M	5	100	80	75	535	345	280	1200	205	790	505	465	90	19	30	0	113	176	176	1147	172
	132S	5	100	80	75	535	345	280	1200	205	790	505	465	90	19	30	0	93	176	176	1219	185
	132M	5	100	80	75	535	345	280	1200	205	790	505	465	90	19	30	0	93	176	176	1256	196
	160M	6	100	80	75	535	390	280	1300	215	870	510	460	90	24	13	25	90	176	176	1365	270
	160L	6	100	80	75	535	390	280	1300	215	870	510	460	90	24	13	25	90	176	176	1409	283
	180M	7	100	80	75	535	390	280	1450	235	980	560	510	90	24	13	25	70	176	176	1385	335
	180L	7	100	80	75	535	390	280	1450	235	980	560	510	90	24	13	25	70	176	176	1463	355
	200L	7	100	80	75	535	390	280	1450	235	980	560	510	90	24	13	25	50	176	176	1516	418
80-31	132S	5	100	80	90	557	370	315	1200	205	790	505	465	90	19	30	0	118	205	227	1256	233
	132M	5	100	80	90	557	370	315	1200	205	790	505	465	90	19	30	0	118	205	227	1293	244
	160M	6	100	80	90	557	415	315	1300	215	870	510	460	90	24	13	25	115	205	227	1402	318
	160L	6	100	80	90	557	415	315	1300	215	870	510	460	90	24	13	25	115	205	227	1446	331
	180M	7	100	80	90	557	415	315	1450	235	980	560	510	90	24	13	25	95	205	227	1422	383
	180L	7	100	80	90	557	415	315	1450	235	980	560	510	90	24	13	25	95	205	227	1500	403
	200L	7	100	80	90	557	415	315	1450	235	980	560	510	90	24	13	25	75	205	227	1553	466
	225S	7	100	80	90	557	415	315	1450	235	980	560	510	90	24	13	25	50	205	227	1588	511
	225M	7	100	80	90	557	415	315	1450	235	980	560	510	90	24	13	25	50	205	227	1613	553
100-25 <sup>(a)</sup>	132S	5	125	100	90	545	345	280	1200	205	790	505	465	90	19	30	0	93	183	216	1244	203
	132M	5	125	100	90	545	345	280	1200	205	790	505	465	90	19	30	0	93	183	216	1281	214
	160M	6	125	100	90	545	390	280	1300	215	870	510	460	90	24	13	25	90	183	216	1390	287
	160L	6	125	100	90	545	390	280	1300	215	870	510	460	90	24	13	25	90	183	216	1434	300
	180M	7	125	100	90	545	390	280	1450	235	980	560	510	90	24	13	25	70	183	216	1410	353
	180L	7	125	100	90	545	390	280	1450	235	980	560	510	90	24	13	25	70	183	216	1488	373
200L	7	125	100	90	545	390	280	1450	235	980	560	510	90	24	13	25	50	183	216	1541	436	

Quote e pesi possono variare senza preavviso  
Dimensions and weights can change without prior notice

(\*) Lunghezza e peso possono variare in funzione della marca del motore  
(\*) Length and weight may vary, it depends by the motor brand

(a) Solo per RB  
(a) Only for RB type

Ingombri su base con giunto spaziatore  
Overall dimensions on base with spacer coupling

Girante multi-canale chiusa e aperta  
Closed and open multi-channel impeller

Pompa tipo Pump size	Grandezza motore Motor size	Base Base plate	Dimensioni Dimensions (mm)																		Peso Weight (kg) <sup>(*)</sup>	
			Dna	Dnm	a	f	h3	h2	L1	L2	L3	B2	B3	w	d	b	c1	c2	l1	l2		T <sub>(r)</sub>
125-25 <sup>(a)</sup>	132S	5	150	125	112	557	370	355	1200	205	790	505	465	90	19	30	0	118	208	254	1278	227
	132M	5	150	125	112	557	370	355	1200	205	790	505	465	90	19	30	0	118	208	254	1315	238
	160M	6	150	125	112	557	415	355	1300	215	870	510	460	90	24	13	25	115	208	254	1424	312
	160L	6	150	125	112	557	415	355	1300	215	870	510	460	90	24	13	25	115	208	254	1468	325
	180M	7	150	125	112	557	415	355	1450	235	980	560	510	90	24	13	25	95	208	254	1444	377
	180L	7	150	125	112	557	415	355	1450	235	980	560	510	90	24	13	25	95	208	254	1522	397
	200L	7	150	125	112	557	415	355	1450	235	980	560	510	90	24	13	25	75	208	254	1575	460
	225S	7	150	125	112	557	415	355	1450	235	980	560	510	90	24	13	25	50	208	254	1610	505
125-31	132M	6	150	125	112	569	445	355	1300	215	870	510	460	110	24	13	25	173	223	256	1327	270
	160M	7	150	125	112	569	445	355	1450	235	980	560	510	110	24	13	25	145	223	256	1436	349
	160L	7	150	125	112	569	445	355	1450	235	980	560	510	110	24	13	25	145	223	256	1480	362
	180M	7	150	125	112	569	445	355	1450	235	980	560	510	110	24	13	25	125	223	256	1456	407
	180L	7	150	125	112	569	445	355	1450	235	980	560	510	110	24	13	25	125	223	256	1534	427
	200L	7	150	125	112	569	445	355	1450	235	980	560	510	110	24	13	25	105	223	256	1587	490
	225S	8	150	125	112	569	445	355	1590	235	1120	560	510	110	24	13	25	80	223	256	1622	539
	225M	8	150	125	112	569	445	355	1590	235	1120	560	510	110	24	13	25	80	223	256	1647	581
	250M	8	150	125	112	569	445	355	1590	235	1120	560	510	110	24	13	25	55	223	256	1709	698
125-40	132M	6	150	125	110	563	480	400	1300	215	870	510	460	110	24	13	25	208	254	288	1317	302
	160M	6	150	125	110	563	480	400	1300	215	870	510	460	110	24	13	25	180	254	288	1426	374
	160L	7	150	125	110	563	480	400	1450	235	980	560	510	110	24	13	25	180	254	288	1470	395
	180M	7	150	125	110	563	480	400	1450	235	980	560	510	110	24	13	25	160	254	288	1446	440
	180L	7	150	125	110	563	480	400	1450	235	980	560	510	110	24	13	25	160	254	288	1524	460
	200L	7	150	125	110	563	480	400	1450	235	980	560	510	110	24	13	25	140	254	288	1577	523
	225S	8	150	125	110	563	480	400	1590	235	1120	560	510	110	24	13	25	115	254	288	1612	571
	225M	8	150	125	110	563	480	400	1590	235	1120	560	510	110	24	13	25	115	254	288	1637	613
	250M	8	150	125	110	563	480	400	1590	235	1120	560	510	110	24	13	25	90	254	288	1699	730
	280S	8	150	125	110	563	480	400	1590	235	1120	560	510	110	24	13	25	60	254	288	1839	877
	280M	9	150	125	110	563	520	400	1900	260	1380	610	560	110	26	15	25	60	254	288	1889	967
315S	9	150	125	110	563	520	400	1900	260	1380	610	560	110	26	15	25	25	254	288	2004	1169	
150-31 <sup>(a)</sup>	132M	7	200	150	120	566	480	400	1450	235	980	560	510	110	24	13	25	208	243	316	1392	302
	160M	7	200	150	120	566	480	400	1450	235	980	560	510	110	24	13	25	180	243	316	1501	374
	160L	7	200	150	120	566	480	400	1450	235	980	560	510	110	24	13	25	180	243	316	1545	387
	180M	7	200	150	120	566	480	400	1450	235	980	560	510	110	24	13	25	160	243	316	1521	432
	180L	7	200	150	120	566	480	400	1450	235	980	560	510	110	24	13	25	160	243	316	1599	452
	200L	8	200	150	120	566	480	400	1590	235	1120	560	510	110	24	13	25	140	243	316	1652	519
	225S	8	200	150	120	566	480	400	1590	235	1120	560	510	110	24	13	25	115	243	316	1687	564
	225M	8	200	150	120	566	480	400	1590	235	1120	560	510	110	24	13	25	115	243	316	1712	606
	250M	8	200	150	120	566	480	400	1590	235	1120	560	510	110	24	13	25	90	243	316	1774	723
	280S	9	200	150	120	566	520	400	1900	260	1380	610	560	110	26	15	25	60	243	316	1914	907
150-35 <sup>(a)</sup>	180M	8	200	150	200	700	480	400	1590	235	1120	560	510	110	24	13	25	160	257	300	1735	533
	180L	8	200	150	200	700	480	400	1590	235	1120	560	510	110	24	13	25	160	257	300	1813	553
	200L	9	200	150	200	700	520	400	1900	260	1380	610	560	110	26	15	25	140	257	300	1866	653
	225S	9	200	150	200	700	520	400	1900	260	1380	610	560	110	26	15	25	115	257	300	1901	698
	225M	9	200	150	200	700	520	400	1900	260	1380	610	560	110	26	15	25	115	257	300	1926	740
	250M	9	200	150	200	700	520	400	1900	260	1380	610	560	110	26	15	25	90	257	300	1988	857
	280S	9	200	150	200	700	520	400	1900	260	1380	610	560	110	26	15	25	60	257	300	2128	1004
	280M	9	200	150	200	700	520	400	1900	260	1380	610	560	110	26	15	25	60	257	300	2178	1057
	315S	10	200	150	200	700	520	400	2000	260	1480	710	660	110	26	15	25	25	257	300	2293	1273
	315M	10	200	150	200	700	520	400	2000	260	1480	710	660	110	26	15	25	25	257	300	2431	1528



Quote e pesi possono variare senza preavviso  
Dimensions and weights can change without prior notice

(\*) Lunghezza e peso possono variare in funzione della marca del motore  
(\*). Length and weight may vary, it depends by the motor brand

(\*) Solo per RB  
(\*). Only for RB type

Ingombri su base con giunto spaziatore  
Overall dimensions on base with spacer coupling

Girante multi-canale chiusa e aperta  
Closed and open multi-channel impeller

Pompa tipo Pump size	Grandezza motore Motor size	Base Base plate	Dimensioni Dimensions (mm)																		Peso Weight (kg) <sup>(*)</sup>	
			Dna	Dnm	a	f	h3	h2	L1	L2	L3	B2	B3	w	d	b	c1	c2	l1	l2		T <sub>(r)</sub>
200-35 <sup>(a)</sup>	200L	9	250	200	250	712	560	450	1900	260	1380	610	560	110	26	15	25	180	275	352	1928	699
	225S	9	250	200	250	712	560	450	1900	260	1380	610	560	110	26	15	25	155	275	352	1963	744
	225M	9	250	200	250	712	560	450	1900	260	1380	610	560	110	26	15	25	155	275	352	1988	786
	250M	9	250	200	250	712	560	450	1900	260	1380	610	560	110	26	15	25	130	275	352	2050	903
	280S	9	250	200	250	712	560	450	1900	260	1380	610	560	110	26	15	25	100	275	352	2190	1050
	280M	9	250	200	250	712	560	450	1900	260	1380	610	560	110	26	15	25	100	275	352	2240	1103
	315S	10	250	200	250	712	560	450	2000	260	1480	710	660	110	26	15	25	65	275	352	2355	1318
	315M	10	250	200	250	712	560	450	2000	260	1480	710	660	110	26	15	25	65	275	352	2493	1573
200-45 <sup>(a)</sup>	200L	9	250	200	250	932	585	500	1900	260	1380	610	560	110	26	15	25	205	315	382	2198	898
	225S	10	250	200	250	932	585	500	2000	260	1480	710	660	110	26	15	25	180	315	382	2233	957
	225M	10	250	200	250	932	585	500	2000	260	1480	710	660	110	26	15	25	180	315	382	2258	999
	250M	10	250	200	250	932	585	500	2000	260	1480	710	660	110	26	15	25	155	315	382	2320	1116
	280S	11	250	200	250	932	625	500	2300	350	1600	820	750	110	30	18	25	125	315	382	2460	1332
	280M	11	250	200	250	932	625	500	2300	350	1600	820	750	110	30	18	25	125	315	382	2510	1385
	315S	11	250	200	250	932	625	500	2300	350	1600	820	750	110	30	18	25	90	315	382	2625	1587
	315M	11	250	200	250	932	625	500	2300	350	1600	820	750	110	30	18	25	90	315	382	2763	1842
250-35 <sup>(a)</sup>	180L	10	300	250	300	727	560	500	2000	260	1480	710	660	140	26	15	25	200	286	371	1940	703
	200L	10	300	250	300	727	560	500	2000	260	1480	710	660	140	26	15	25	180	286	371	1993	766
	225S	10	300	250	300	727	560	500	2000	260	1480	710	660	140	26	15	25	155	286	371	2028	811
	225M	10	300	250	300	727	560	500	2000	260	1480	710	660	140	26	15	25	155	286	371	2053	853
	250M	10	300	250	300	727	560	500	2000	260	1480	710	660	140	26	15	25	130	286	371	2115	970
	280S	10	300	250	300	727	560	500	2000	260	1480	710	660	140	26	15	25	100	286	371	2255	1117
	280M	10	300	250	300	727	560	500	2000	260	1480	710	660	140	26	15	25	100	286	371	2305	1170
	315S	10	300	250	300	727	560	500	2000	260	1480	710	660	140	26	15	25	65	286	371	2420	1372
315M	10	300	250	300	727	560	500	2000	260	1480	710	660	140	26	15	25	65	286	371	2558	1627	
250-45 <sup>(a)</sup>	225M	10	300	250	300	944	630	560	2000	260	1480	710	660	140	26	15	25	225	349	450	2320	1089
	250M	11	300	250	300	944	670	560	2300	350	1600	820	750	140	30	18	25	200	349	450	2382	1275
	280S	11	300	250	300	944	670	560	2300	350	1600	820	750	140	30	18	25	170	349	450	2522	1422
	280M	11	300	250	300	944	670	560	2300	350	1600	820	750	140	30	18	25	170	349	450	2572	1475
	315S	11	300	250	300	944	670	560	2300	350	1600	820	750	140	30	18	25	135	349	450	2687	1677
	315M	11	300	250	300	944	670	560	2300	350	1600	820	750	140	30	18	25	135	349	450	2825	1932
	315L	11	300	250	300	944	670	560	2300	350	1600	820	750	140	30	18	25	135	349	450	2825	1987
	355L	12	300	250	300	944	670	560	2900	500	1900	820	750	140	30	18	25	95	349	450	3058	2689
300-45 <sup>(a)</sup>	250M	11	350	300	300	959	695	600	2300	350	1600	820	750	190	30	18	25	225	377	485	2397	1366
	280S	11	350	300	300	959	695	600	2300	350	1600	820	750	190	30	18	25	195	377	485	2537	1513
	280M	11	350	300	300	959	695	600	2300	350	1600	820	750	190	30	18	25	195	377	485	2587	1566
	315S	11	350	300	300	959	695	600	2300	350	1600	820	750	190	30	18	25	160	377	485	2702	1768
	315M	12	350	300	300	959	695	600	2900	500	1900	820	750	190	30	18	25	160	377	485	2840	2046
	315L	12	350	300	300	959	695	600	2900	500	1900	820	750	190	30	18	25	160	377	485	2840	2101
	355L	12	350	300	300	959	695	600	2900	500	1900	820	750	190	30	18	25	120	377	485	3073	2781
300-46 <sup>(a)</sup>	250M	11	350	300	300	959	695	600	2300	350	1600	820	750	190	30	18	25	225	377	485	2397	1366
	280S	11	350	300	300	959	695	600	2300	350	1600	820	750	190	30	18	25	195	377	485	2537	1513
	280M	11	350	300	300	959	695	600	2300	350	1600	820	750	190	30	18	25	195	377	485	2587	1566
	315S	11	350	300	300	959	695	600	2300	350	1600	820	750	190	30	18	25	160	377	485	2702	1768
	315M	12	350	300	300	959	695	600	2900	500	1900	820	750	190	30	18	25	160	377	485	2840	2046
	315L	12	350	300	300	959	695	600	2900	500	1900	820	750	190	30	18	25	160	377	485	2840	2101
	355L	12	350	300	300	959	695	600	2900	500	1900	820	750	190	30	18	25	120	377	485	3073	2781
400-60 <sup>(a)</sup>	315L	13	450	400	350	1096	835	820	3100	600	1900	1170	1100	250	24	18	35	280	466	615	3255	4150
	355L	13	450	400	350	1096	835	820	3100	600	1900	1170	1100	250	24	18	35	240	466	615	3380	4350

Quote e pesi possono variare senza preavviso  
Dimensions and weights can change without prior notice

(\*) Lunghezza e peso possono variare in funzione della marca del motore  
(\*) Length and weight may vary, it depends by the motor brand

(\*) Solo per RB  
(\*) Only for RB type

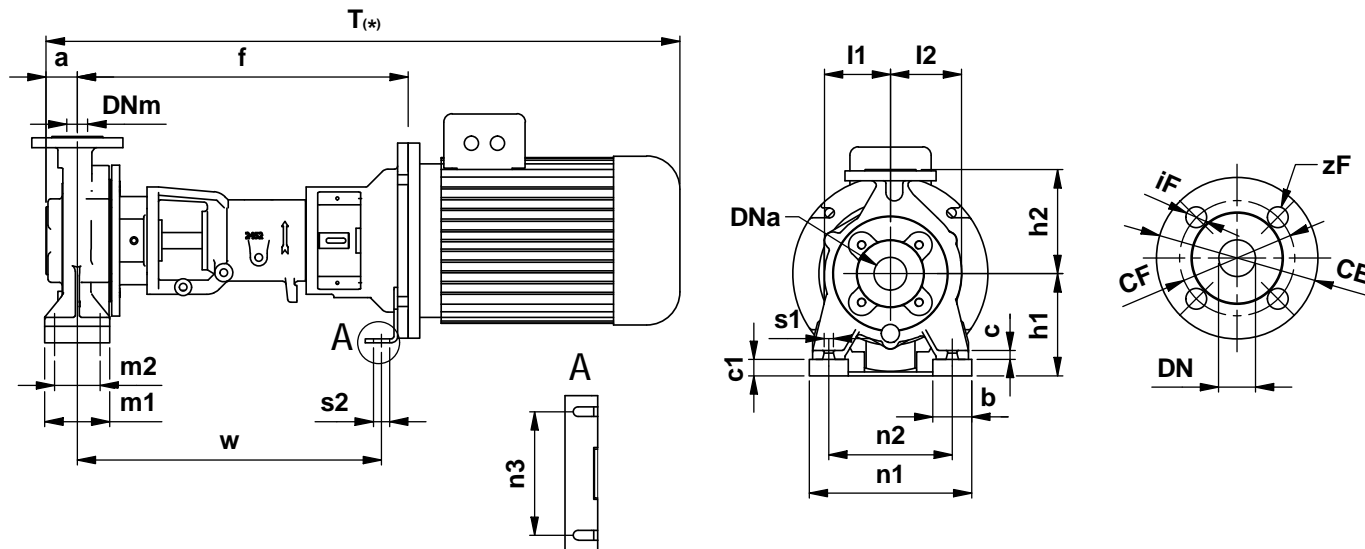

**Dimensioni Flange**  
**Dimensions Flange EN1092-1/2 PN10**

<b>DNa-DNm</b>	65	80	100	125	150	200
<b>CF</b>	145	160	180	210	240	295
<b>DE</b>	185	200	220	250	285	340
<b>iF</b>	18	18	18	18	22	23
<b>zF</b>	4	8	8	8	8	8

**Accoppiamento potenza – polarità/grandezza motore**  
**Power – polarity/motor size coupling**

<b>Poli</b>	G/kW	G/kW	G/kW	G/kW	G/kW	G/kW	G/kW	G/kW	G/kW	G/kW	G/kW	G/kW	G/kW	G/kW
<b>2</b>	71	80	80	90S	90L	100L	112M	132S	132S	132M	160M	160M	160L	180M
	0,55	0,75	1,1	1,5	2,2	3	4	5,5	7,5	9,2	11	15	18,5	22
<b>4</b>	80	80	90S	90L	100L	100L	112M	132S	132M	132M	160M	160L	180M	180L
	0,55	0,75	1,1	1,5	2,2	3	4	5,5	7,5	9,2	11	15	18,5	22
<b>6</b>	80	90S	90L	100L	112M	132S	132M	132M	160M	160L	180L	-	-	-
	0,55	0,75	1,1	1,5	2,2	3	4	5,5	7,5	11	15	-	-	-

Quote e pesi possono variare senza preavviso  
Dimensions and weights can change without prior notice

(\*) Lunghezza e peso possono variare in funzione della marca del motore  
(\* Length and weight may vary, it depends by the motor brand

Ingombri lanterna  
Lantern bracket overall dimensions

Girante multi-canale chiusa e aperta  
Closed and open multi-channel impeller

Pompa tipo Pump size	Grandezza motore Motor size	Dimensioni Dimensions (mm)																			Peso Weight (kg) <sup>(*)</sup>	
		Dna	Dnm	a	f	h1	h2	b	m1	m2	n1	n2	n3	w	s1	s2	c	c1	l1	l2		T <sub>(c)</sub>
65-20 <sup>(a)</sup>	100	80	65	66	584	180	225	65	125	95	320	250	110	537	14	15	16	0	151	151	1035	97
	112	80	65	66	584	180	225	65	125	95	320	250	110	537	14	15	16	0	151	151	1039	104
	132	80	65	66	604	180	225	65	125	95	320	250	190	564	14	15	16	0	151	151	1168	130
	160	80	65	66	634	180	225	65	125	95	320	250	212	582	14	19	16	0	151	151	1351	222
	180	80	65	66	634	180	225	65	125	95	320	250	212	582	14	19	16	0	151	151	1405	287
80-20 <sup>(a)</sup>	100	100	80	68	592	180	250	65	125	95	345	280	110	545	14	15	16	0	159	159	1045	101
	112	100	80	68	592	180	250	65	125	95	345	280	110	545	14	15	16	0	159	159	1049	108
	132	100	80	68	612	180	250	65	125	95	345	280	190	572	14	15	16	0	159	159	1178	134
	160	100	80	68	642	180	250	65	125	95	345	280	212	590	14	19	16	0	159	159	1361	226
	180	100	80	68	642	180	250	65	125	95	345	280	212	590	14	19	16	0	159	159	1415	291
80-25 <sup>(a)</sup>	100	100	80	75	597	225	280	70	160	120	395	315	110	550	18	15	18	0	176	176	1057	121
	112	100	80	75	597	225	280	70	160	120	395	315	110	550	18	15	18	0	176	176	1061	128
	132	100	80	75	617	225	280	70	160	120	395	315	190	577	18	15	18	0	176	176	1190	154
	160	100	80	75	647	225	280	70	160	120	395	315	212	595	18	19	18	0	176	176	1373	246
	180	100	80	75	647	225	280	70	160	120	395	315	212	595	18	19	18	0	176	176	1427	311
80-31	112	100	80	90	624	250	315	80	160	120	400	315	110	577	18	15	18	0	205	227	1103	184
	132	100	80	90	644	250	315	80	160	120	400	315	190	604	18	15	18	0	205	227	1232	210
	160	100	80	90	674	250	315	80	160	120	400	315	212	623	18	19	18	0	205	227	1415	301
	180	100	80	90	674	250	315	80	160	120	400	315	212	623	18	19	18	0	205	227	1469	366
100-25 <sup>(a)</sup>	112	125	100	90	607	225	280	80	160	120	400	315	110	560	18	15	18	0	183	216	1086	146
	132	125	100	90	627	225	280	80	160	120	400	315	190	587	18	15	18	0	183	216	1215	172
	160	125	100	90	657	225	280	80	160	120	400	315	212	605	18	19	18	0	183	216	1398	263
	180	125	100	90	657	225	280	80	160	120	400	315	212	605	18	19	18	0	183	216	1452	328
125-25 <sup>(a)</sup>	112	150	125	112	619	250	355	80	160	120	400	315	110	573	18	15	18	0	208	254	1120	170
	132	150	125	112	639	250	355	80	160	120	400	315	190	600	18	15	18	0	208	254	1249	196
	160	150	125	112	669	250	355	80	160	120	400	315	212	618	18	19	18	0	208	254	1432	288
	180	150	125	112	669	250	355	80	160	120	400	315	212	618	18	19	18	0	208	254	1486	353
125-31	132	150	125	112	656	280	355	100	200	160	500	400	190	617	23	15	20	0	223	256	1266	234
	160	150	125	112	686	280	355	100	200	160	500	400	212	636	23	19	20	0	223	256	1449	325
	180	150	125	112	686	280	355	100	200	160	500	400	212	636	23	19	20	0	223	256	1503	390
150-31 <sup>(a)</sup>	132	200	150	120	653	315	400	100	200	150	550	450	190	613	24	15	22	0	243	316	1271	259
	160	200	150	120	683	315	400	100	200	150	550	450	212	632	24	19	22	0	243	316	1454	350
	180	200	150	120	683	315	400	100	200	150	550	450	212	632	24	19	22	0	243	316	1508	415

Quote e pesi possono variare senza preavviso  
Dimensions and weights can change without prior notice

(\*) Lunghezza e peso possono variare in funzione della marca del motore  
(\*) Length and weight may vary, it depends by the motor brand

(\*) Solo per RB  
(\*) Only for RB type

Ingombri lanternata su base  
Lantern bracket on base overall dimensions

Girante multi-canale chiusa e aperta  
Closed and open multi-channel impeller

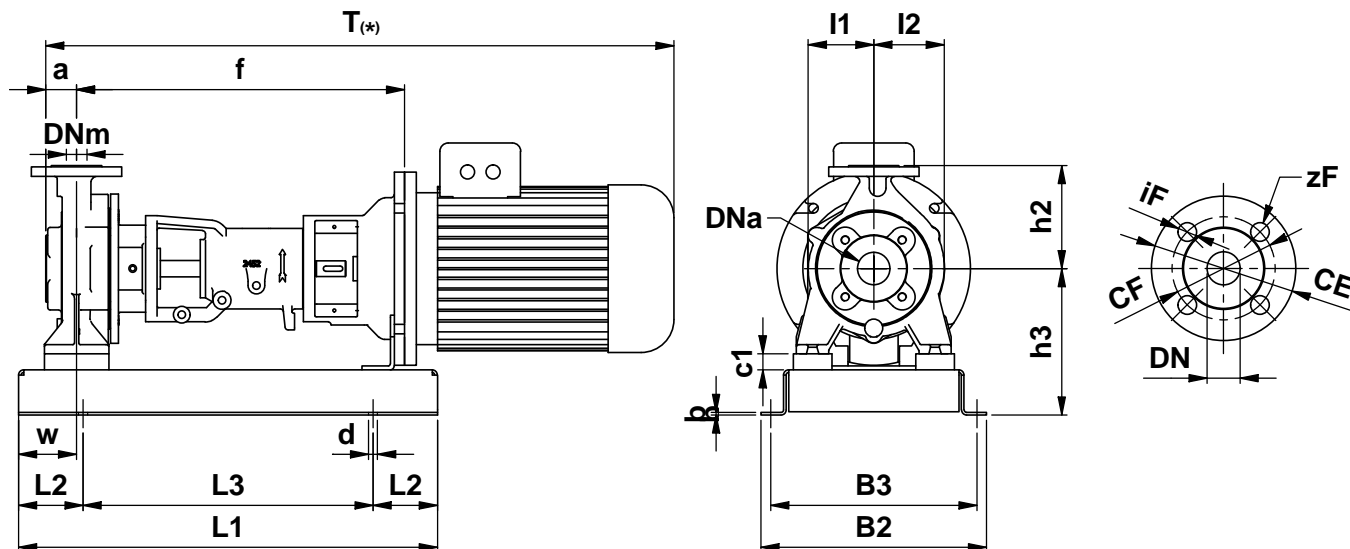

**Dimensioni Flange**  
**Dimensions Flange EN1092-1 PN16**

<b>DNa-DNm</b>	65	80	100	125	150	200
<b>CF</b>	145	160	180	210	240	295
<b>DE</b>	185	200	220	250	285	340
<b>iF</b>	18	18	18	18	22	23
<b>zF</b>	4	8	8	8	8	8

**Accoppiamento potenza – polarità/grandezza motore**  
**Power – polarity/motor size coupling**

<b>Poli</b>	G/kW	G/kW	G/kW	G/kW	G/kW	G/kW	G/kW	G/kW	G/kW	G/kW	G/kW	G/kW	G/kW	G/kW
<b>2</b>	71	80	80	90S	90L	100L	112M	132S	132S	132M	160M	160M	160L	180M
	0,55	0,75	1,1	1,5	2,2	3	4	5,5	7,5	9,2	11	15	18,5	22
<b>4</b>	80	80	90S	90L	100L	100L	112M	132S	132M	132M	160M	160L	180M	180L
	0,55	0,75	1,1	1,5	2,2	3	4	5,5	7,5	9,2	11	15	18,5	22
<b>6</b>	80	90S	90L	100L	112M	132S	132M	132M	160M	160L	180L	-	-	-
	0,55	0,75	1,1	1,5	2,2	3	4	5,5	7,5	11	15	-	-	-

Quote e pesi possono variare senza preavviso  
Dimensions and weights can change without prior notice

(\*) Lunghezza e peso possono variare in funzione della marca del motore  
(\*) Length and weight may vary, it depends by the motor brand

Ingombri lanternata su base  
Lantern bracket on base overall dimensions

Girante multi-canale chiusa e aperta  
Closed and open multi-channel impeller

Pompa tipo Pump size	Grandezza motore Motor size	Base Base plate	Dimensioni Dimensions (mm)																	Peso Weight (kg) <sup>(*)</sup>	
			Dna	Dnm	a	f	h2	h3	L1	L2	L3	B2	B3	w	d	b	c1	l1	l2		T <sub>(*)</sub>
65-20 <sup>(a)</sup>	100	G2	80	65	66	584	225	250	850	150	550	510	460	120	16	6	0	151	151	1035	118
	112	G2	80	65	66	584	225	250	850	150	550	510	460	120	16	6	0	151	151	1039	125
	132	G2	80	65	66	604	225	250	850	150	550	510	460	120	16	6	0	151	151	1168	151
	160	G2	80	65	66	634	225	250	850	150	550	510	460	120	16	6	0	151	151	1351	242
	180	G2	80	65	66	634	225	250	850	150	550	510	460	120	16	6	0	151	151	1405	307
80-20 <sup>(a)</sup>	100	G2	100	80	68	592	250	250	850	150	550	510	460	120	16	6	0	159	159	1045	121
	112	G2	100	80	68	592	250	250	850	150	550	510	460	120	16	6	0	159	159	1049	128
	132	G2	100	80	68	612	250	250	850	150	550	510	460	120	16	6	0	159	159	1178	154
	160	G2	100	80	68	642	250	250	850	150	550	510	460	120	16	6	0	159	159	1361	246
	180	G2	100	80	68	642	250	250	850	150	550	510	460	120	16	6	0	159	159	1415	311
80-25 <sup>(a)</sup>	100	G2	100	80	75	597	280	295	850	150	550	510	460	120	16	6	0	176	176	1057	141
	112	G2	100	80	75	597	280	295	850	150	550	510	460	120	16	6	0	176	176	1061	148
	132	G2	100	80	75	617	280	295	850	150	550	510	460	120	16	6	0	176	176	1190	174
	160	G2	100	80	75	647	280	295	850	150	550	510	460	120	16	6	0	176	176	1373	266
	180	G2	100	80	75	647	280	295	850	150	550	510	460	120	16	6	0	176	176	1427	331
80-31	112	G3	100	80	90	624	315	350	1000	200	600	650	590	140	20	8	0	205	227	1103	238
	132	G3	100	80	90	644	315	350	1000	200	600	650	590	140	20	8	0	205	227	1232	264
	160	G3	100	80	90	674	315	350	1000	200	600	650	590	140	20	8	0	205	227	1415	356
	180	G3	100	80	90	674	315	350	1000	200	600	650	590	140	20	8	0	205	227	1469	421
100-25 <sup>(a)</sup>	112	G2	125	100	90	607	280	295	850	150	550	510	460	120	16	6	0	183	216	1086	166
	132	G2	125	100	90	627	280	295	850	150	550	510	460	120	16	6	0	183	216	1215	192
	160	G2	125	100	90	657	280	295	850	150	550	510	460	120	16	6	0	183	216	1398	283
	180	G2	125	100	90	657	280	295	850	150	550	510	460	120	16	6	0	183	216	1452	348
125-25 <sup>(a)</sup>	112	G2	150	125	112	619	355	320	850	150	550	510	460	120	16	6	0	208	254	1120	190
	132	G2	150	125	112	639	355	320	850	150	550	510	460	120	16	6	0	208	254	1249	216
	160	G2	150	125	112	669	355	320	850	150	550	510	460	120	16	6	0	208	254	1432	308
	180	G2	150	125	112	669	355	320	850	150	550	510	460	120	16	6	0	208	254	1486	373
125-31	132	G3	150	125	112	656	355	380	1000	200	600	650	590	140	20	8	0	223	256	1266	289
	160	G3	150	125	112	686	355	380	1000	200	600	650	590	140	20	8	0	223	256	1449	380
	180	G3	150	125	112	686	355	380	1000	200	600	650	590	140	20	8	0	223	256	1503	445
150-31 <sup>(a)</sup>	112	G3	200	150	120	633	400	415	1000	200	600	650	590	140	20	8	0	243	316	1142	256
	132	G3	200	150	120	653	400	415	1000	200	600	650	590	140	20	8	0	243	316	1271	258
	160	G3	200	150	120	683	400	415	1000	200	600	650	590	140	20	8	0	243	316	1454	264
	180	G3	200	150	120	683	400	415	1000	200	600	650	590	140	20	8	0	243	316	1508	264

Quote e pesi possono variare senza preavviso  
Dimensions and weights can change without prior notice

(\*) Lunghezza e peso possono variare in funzione della marca del motore  
(\*) Length and weight may vary, it depends by the motor brand

(\*) Solo per RB  
(\*) Only for RB type

Ingombri monoblocco  
Close coupled overall dimensions

Girante multi-canale chiusa e aperta  
Closed and open multi-channel impeller

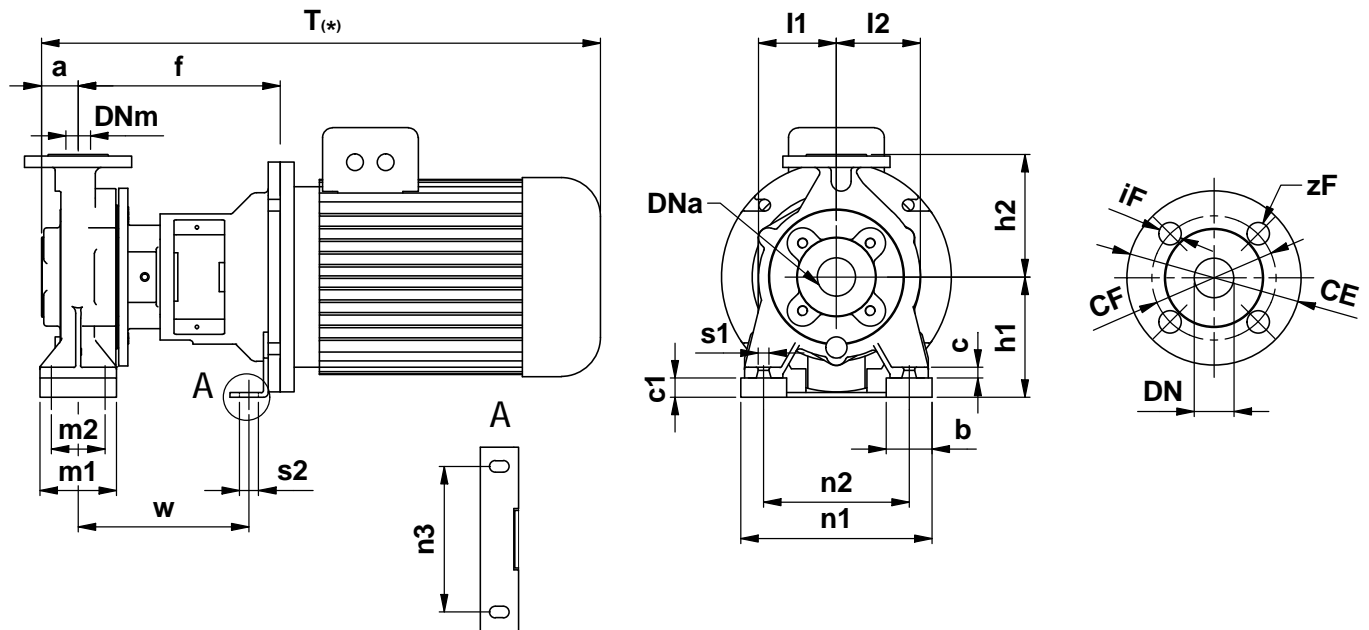

**Dimensioni Flange**  
*Dimensions Flange EN1092-1/2 PN10*

<b>DNa-DNm</b>	65	80	100	125	150
<b>CF</b>	145	160	180	210	240
<b>DE</b>	185	200	220	250	285
<b>iF</b>	18	18	18	18	22
<b>zF</b>	4	8	8	8	8

**Accoppiamento potenza – polarità/grandezza motore**  
*Power – polarity/motor size coupling*

<b>Poli</b>	G/kW	G/kW	G/kW	G/kW	G/kW	G/kW	G/kW	G/kW	G/kW	G/kW	G/kW	G/kW	G/kW	G/kW
<b>2</b>	71	80	80	90S	90L	100L	112M	132S	132S	132M	160M	160M	160L	180M
	0,55	0,75	1,1	1,5	2,2	3	4	5,5	7,5	9,2	11	15	18,5	22
<b>4</b>	80	80	90S	90L	100L	100L	112M	132S	132M	132M	160M	160L	180M	180L
	0,55	0,75	1,1	1,5	2,2	3	4	5,5	7,5	9,2	11	15	18,5	22
<b>6</b>	80	90S	90L	100L	112M	132S	132M	132M	160M	160L	180L	-	-	-
	0,55	0,75	1,1	1,5	2,2	3	4	5,5	7,5	11	15	-	-	-

Quote e pesi possono variare senza preavviso  
Dimensions and weights can change without prior notice

(\*) Lunghezza e peso possono variare in funzione della marca del motore  
(\* Length and weight may vary, it depends by the motor brand

Ingombri monoblocco  
 Close coupled overall dimensions

 Girante multi-canale chiusa e aperta  
 Closed and open multi-channel impeller

Pompa tipo Pump size	Grandezza motore Motor size	Dimensioni Dimensions (Mm)																				Peso Weight (kg) <sup>(*)</sup>
		Dna	Dnm	a	f	h1	h2	b	m1	m2	n1	n2	n3	w	s1	s2	c	c1	l1	l2	T <sup>(*)</sup>	
65-20 <sup>(a)</sup>	100	80	65	66	269	180	225	65	125	95	320	250	110	222	14	15	16	0	151	151	724	97
	112	80	65	66	269	180	225	65	125	95	320	250	110	222	14	15	16	0	151	151	728	104
	132	80	65	66	289	180	225	65	125	95	320	250	190	249	14	15	16	0	151	151	857	130
	160	80	65	66	319	180	225	65	125	95	320	250	212	267	14	19	16	0	151	151	1040	222
	180	80	65	66	319	180	225	65	125	95	320	250	212	267	14	19	16	0	151	151	1094	287
80-20 <sup>(a)</sup>	100	100	80	68	277	180	250	65	125	95	345	280	110	230	14	15	16	0	159	159	734	101
	112	100	80	68	277	180	250	65	125	95	345	280	110	230	14	15	16	0	159	159	738	108
	132	100	80	68	297	180	250	65	125	95	345	280	190	257	14	15	16	0	159	159	867	134
	160	100	80	68	327	180	250	65	125	95	345	280	212	275	14	19	16	0	159	159	1050	226
	180	100	80	68	327	180	250	65	125	95	345	280	212	275	14	19	16	0	159	159	1104	291
80-25 <sup>(a)</sup>	100	100	80	75	282	225	280	70	160	120	395	315	110	235	18	15	18	0	176	176	746	121
	112	100	80	75	282	225	280	70	160	120	395	315	110	235	18	15	18	0	176	176	750	128
	132	100	80	75	302	225	280	70	160	120	395	315	190	262	18	15	18	0	176	176	879	154
	160	100	80	75	332	225	280	70	160	120	395	315	212	280	18	19	18	0	176	176	1062	246
	180	100	80	75	332	225	280	70	160	120	395	315	212	280	18	19	18	0	176	176	1116	311
100-25 <sup>(a)</sup>	112	125	100	90	292	225	280	80	160	120	400	315	110	245	18	15	18	0	183	216	775	146
	132	125	100	90	312	225	280	80	160	120	400	315	190	272	18	15	18	0	183	216	904	172
	160	125	100	90	342	225	280	80	160	120	400	315	212	290	18	19	18	0	183	216	1087	263
	180	125	100	90	342	225	280	80	160	120	400	315	212	290	18	19	18	0	183	216	1141	328
125-25 <sup>(a)</sup>	112	150	125	112	304	250	355	80	160	120	400	315	110	258	18	15	18	0	208	254	809	170
	132	150	125	112	324	250	355	80	160	120	400	315	190	285	18	15	18	0	208	254	938	196
	160	150	125	112	354	250	355	80	160	120	400	315	212	303	18	19	18	0	208	254	1121	288
	180	150	125	112	354	250	355	80	160	120	400	315	212	303	18	19	18	0	208	254	1175	353

 Quote e pesi possono variare senza preavviso  
 Dimensions and weights can change without prior notice

 (\*) Lunghezza e peso possono variare in funzione della marca del motore  
 (\*) Length and weight may vary, it depends by the motor brand

 (a) Solo per RB  
 (a) Only for RB type

**Conessioni**  
**Connections**

**Girante multi-canale chiusa e aperta**  
**Closed and open multi-channel impeller**

**Conessioni pompa con supporto cuscinetti**  
**Pump connections with bearing housing**

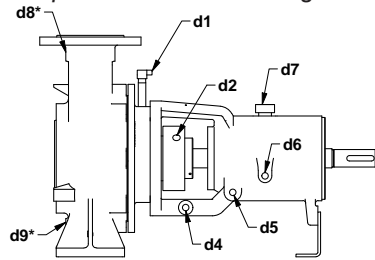

**Conessioni pompa monoblocco**  
**Close coupled pump connections**

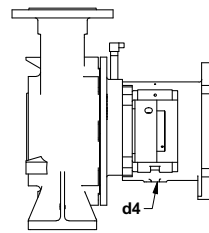

**Conessioni camera di raffreddamento o riscaldamento tenute**  
**Seal cooling/heating jacket connections**

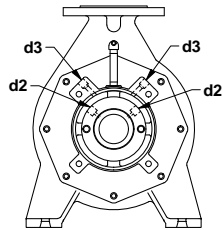

**Conessioni camera di raffreddamento o riscaldamento tenute**  
**Seal cooling/heating jacket connections**

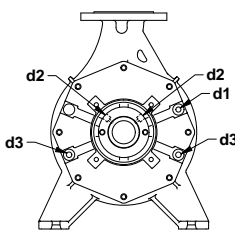

Solo per | Only for  
80-25, 100-25, 125-25

Pompa Tipo Pump Size	Gruppo Supporto Bearing Housing Group	Conessioni Connections holes									
		d1	d2	d3	d4	d5	d6	d7	d8	d9	
65-20	GR2	1/4	1/4	3/8	1/4	1/4	1/4	18	1/4	3/8	
80-20	GR2	1/4	1/4	3/8	1/4	1/4	1/4	18	1/4	3/8	
80-25	GR2	1/4	1/4	3/8	1/4	1/4	1/4	18	1/4	3/8	
80-31	GR3	1/4	1/4	3/8	1/4	1/4	1/4	18	1/2	1/2	
100-25	GR2	1/4	1/4	3/8	1/4	1/4	1/4	18	1/2	1/2	
125-25	GR2	1/4	1/4	3/8	1/4	1/4	1/4	18	1/2	1/2	
125-31	GR3	1/4	1/4	3/8	1/4	1/4	1/4	18	1/2	1/2	
125-40	GR3	1/4	1/4	3/8	1/4	1/4	1/4	18	1/2	1/2	
150-31	GR3	1/4	1/4	3/8	1/4	1/4	1/4	18	1/2	1/2	
150-35	GR4	1/4	1/4	3/8	1/4	1/4	1/4	18	1/2	1/2	
200-35	GR4	1/4	1/4	3/8	1/4	1/4	1/4	18	1/2	3/4	
200-45	GR5	1/4	1/4	3/8	1/4	1/4	1/4	18	1/2	1	
250-35	GR4	1/4	1/4	3/8	1/4	1/4	1/4	18	1/2	1	
250-45	GR5	1/4	1/4	3/8	1/4	1/4	1/4	18	1/2	1	
300-45	GR5	1/4	1/4	3/8	1/4	1/4	1/4	18	1/2	1	
300-46	GR5	1/4	1/4	3/8	1/4	1/4	1/4	18	1/2	1	
400-60	GR6	1/4	1/4	3/8	1/2	1/2	1/4	18	1/2	1	

<b>d1</b>	Entrata liquido dispositivo di tenuta	Flushing sealing device inlet
<b>d2</b>	Ingresso/Uscita liquido dispositivo di tenuta	Flushing sealing device Inlet/Outlet
<b>d3</b>	Ingresso/Uscita liquido di raff. cassastoppa	Stuffing box cooling water Inlet/Outlet
<b>d4</b>	Scarico liquido di gocciolamento tenuta	Seal drain
<b>d5</b>	Svuotamento olio lubrificante cuscinetti	Bearing lubricating oil drain
<b>d6</b>	Attacco oliatore a livello costante	Constant level oil cup connection
<b>d7</b>	Tappo di sfiato con astina	Oil dipstick
<b>d8</b>	Attacco manometro*	Pressure gauge connection*
<b>d9</b>	Drenaggio Corpo*	Casing drain*

(\*) Standard per 125-40, GR4 e GR5, a richiesta sulle altre taglie  
(\*) Standard for 125-40, GR4 and GR5 sizes, on demand for the others

Curve prestazionali redatte secondo classe di accettabilità ISO 9906 - Classe 2B.

I valori di NPSH mostrati si riferiscono ad una caduta di prevalenza totale pari al 3%.

Per portate inferiori a  $Q=0,3 \times Q_{opt}$ . non è possibile fornire valori attendibili di NPSH.

I valori di prevalenza, potenza, NPSH e rendimento si riferiscono a liquidi con densità relativa pari a 1,0 ed una viscosità cinematica massima di 20 mm<sup>2</sup>/s.

In caso di densità relativa ( $\rho_0$ ) diversa da 1,0 sarà necessario moltiplicare il valore della potenza per " $\rho_0$ " e dividere di conseguenza il rendimento per " $\rho_0$ ".

Se la viscosità supera i 20 mm<sup>2</sup>/s, dovranno essere valutati gli effetti della viscosità sui parametri prestazionali della pompa e considerare i relativi dati con acqua fredda. Le curve prestazionali si riferiscono a pompe ad asse orizzontale in esecuzione Asse Nudo e tenuta meccanica singola; per configurazioni diverse (cuscinetti maggiorati, tenute meccaniche doppie, pompe ad asse verticale, ecc..) il rendimento della pompa potrebbe differire da quello indicato a catalogo.

Performance curves according to ISO 9906 - Grade 2B acceptability class.

The given NPSH values correspond to a total head drop of 3%. For flow rates below  $Q = 0.3 \times Q_{opt}$ , no reliable NPSH values can be provided.

Head, power, NPSH and efficiency values refer to liquids with a relative density of 1.0 and a maximum kinematic viscosity of 20 mm<sup>2</sup>/s.

In case of a different relative density ( $\rho_0$ ) than 1.0, it will be necessary to multiply the power value by " $\rho_0$ " and, accordingly, divide the efficiency by " $\rho_0$ ".

If the viscosity exceeds 20 mm<sup>2</sup>/s, the effects of viscosity on the pump's performance parameters must be evaluated, considering the related data with cold water.

The performance curves refer to horizontal pumps with bare shaft execution and single mechanical seal.

For different configurations (oversized bearings, double mechanical seals, vertical-axis pumps, etc.), the pump's efficiency may differ from the one indicated in the catalogue.

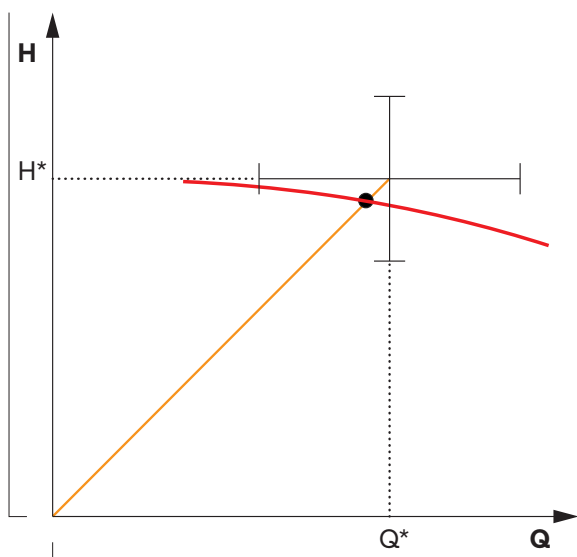

ISO 9906  
Classe 2B  
Grade 2B

$\Delta Q$

±8%

$\Delta H$

±5%

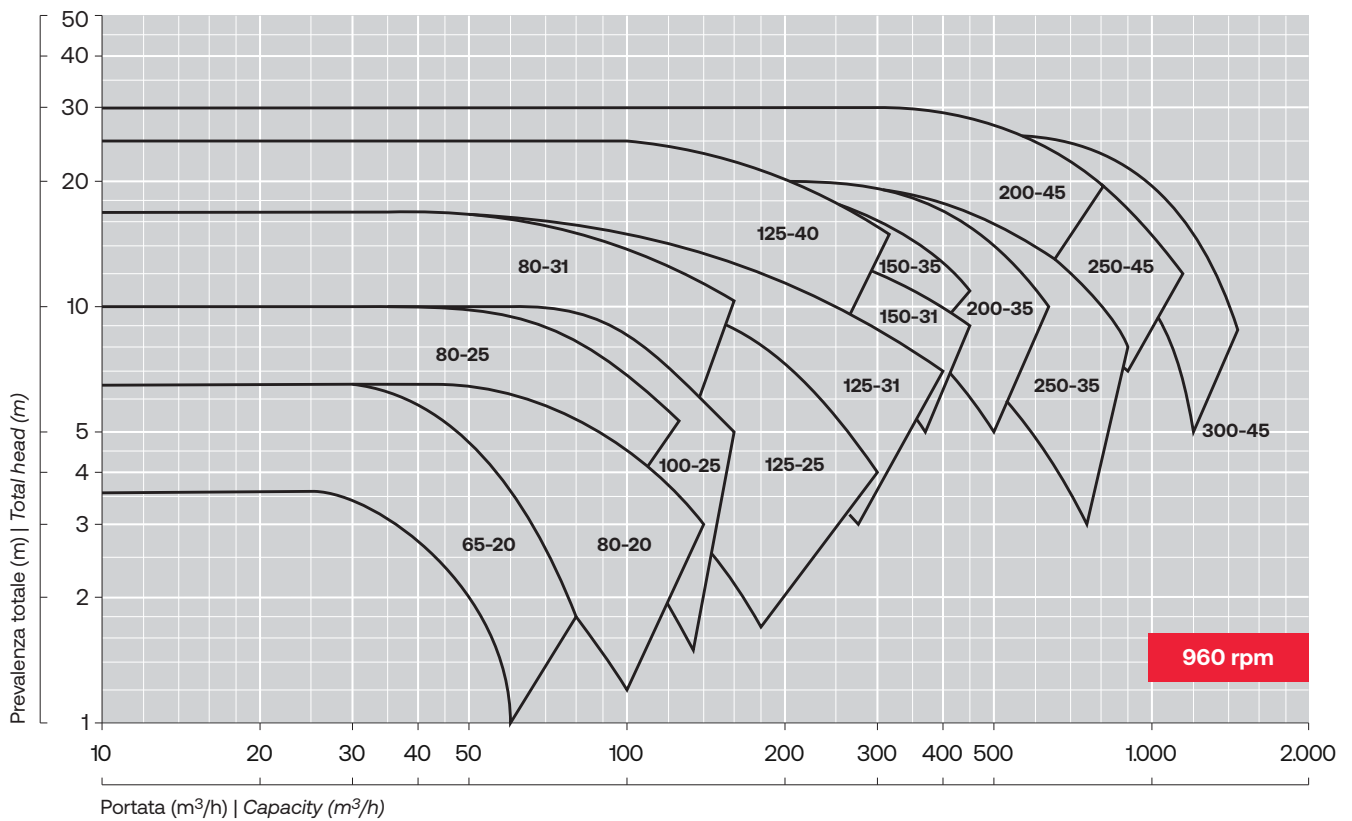
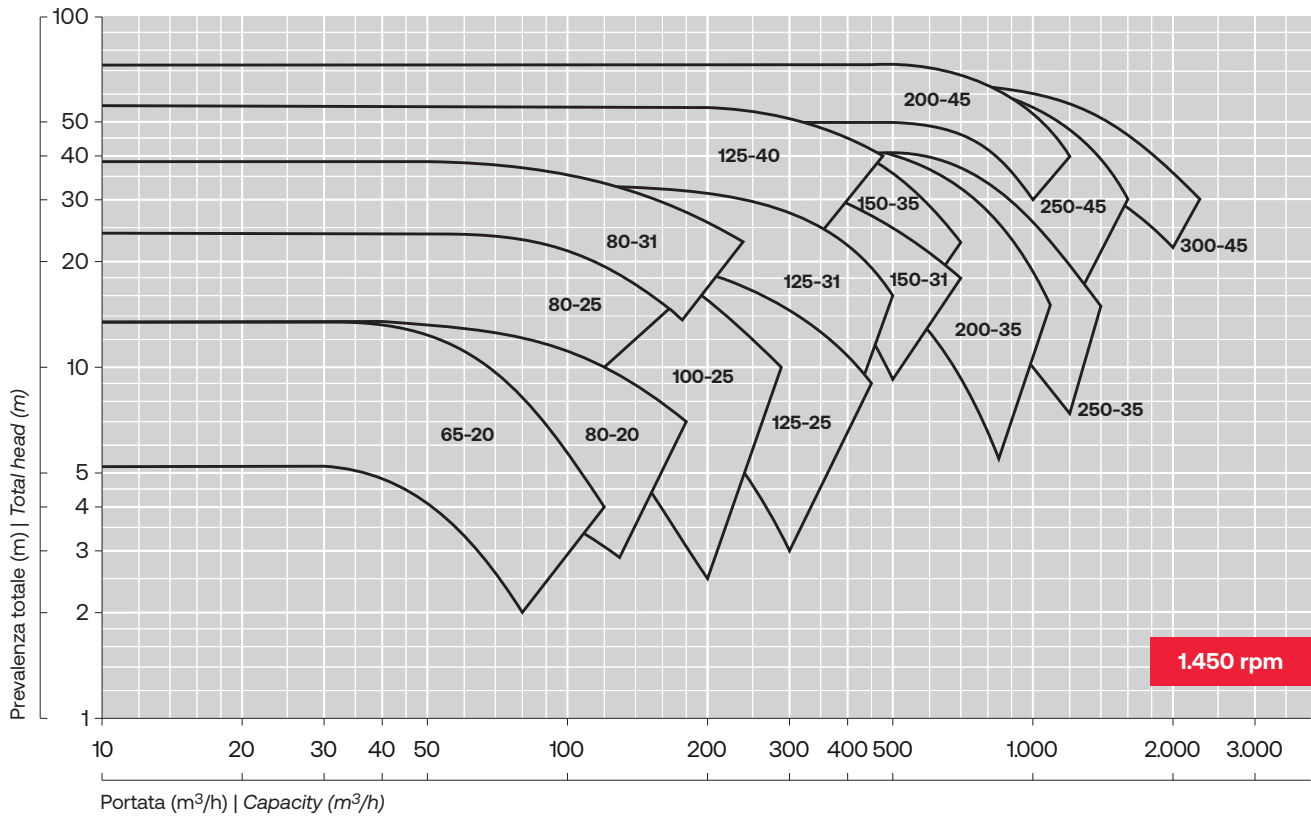

Curve prestazionali  
Performance curves

Girante multi-canale chiusa  
Closed multi-channel impeller

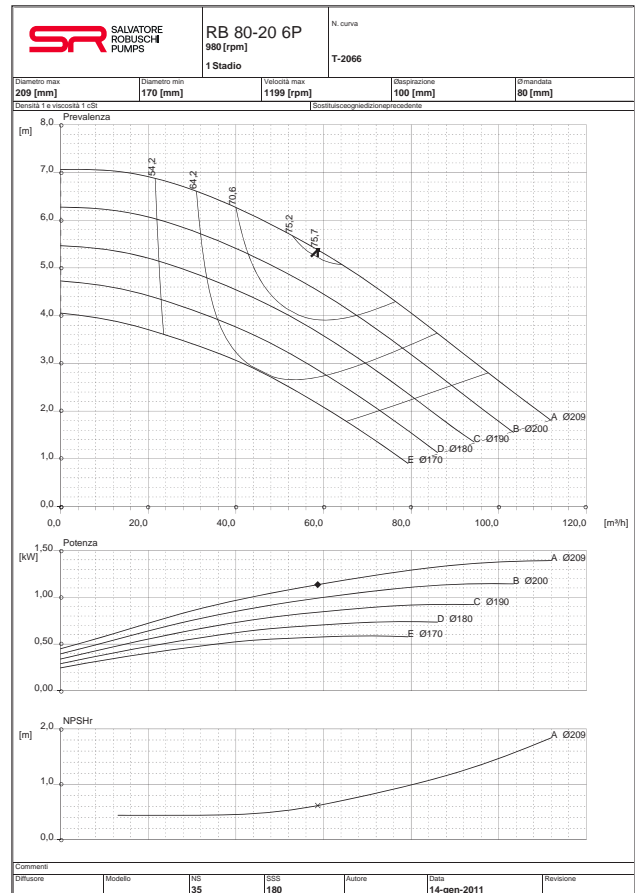
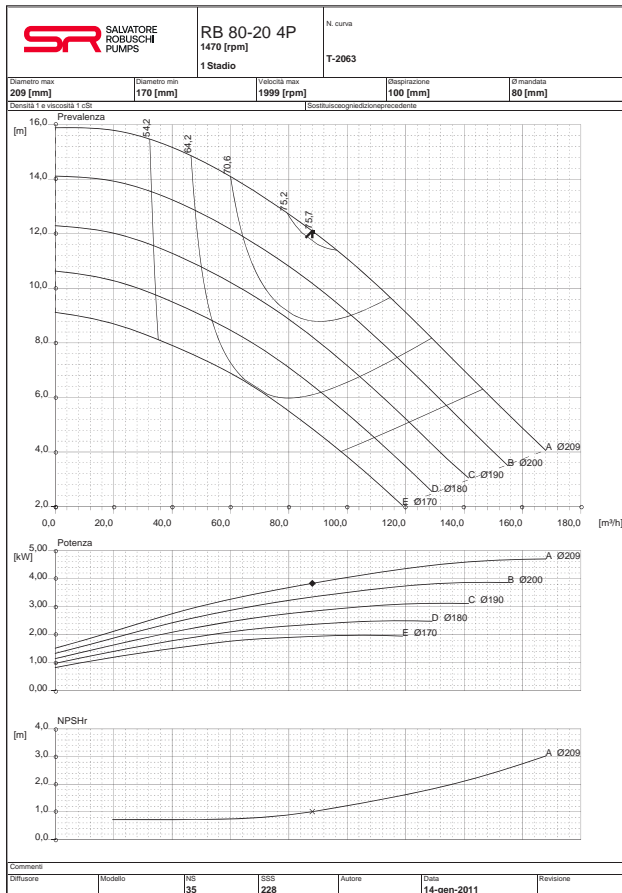
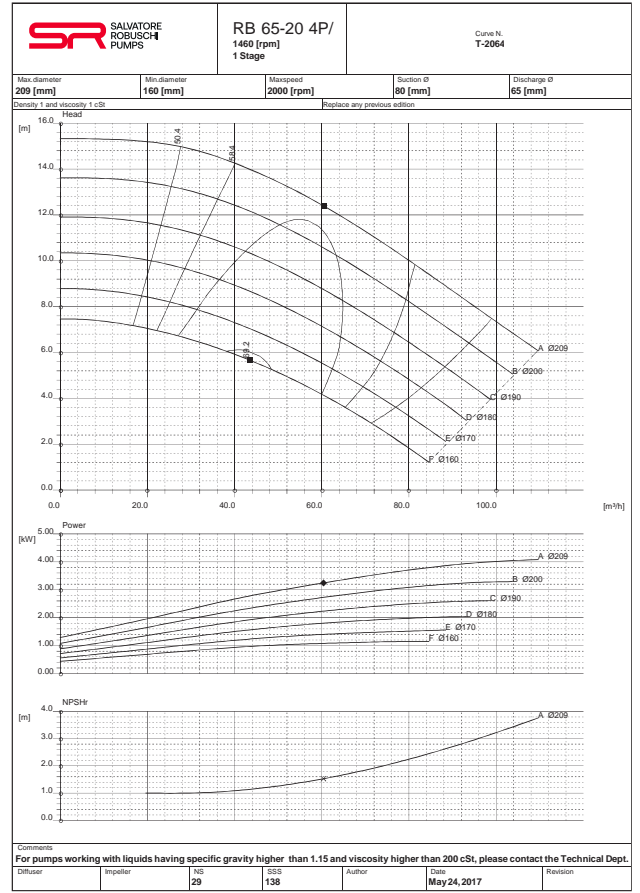
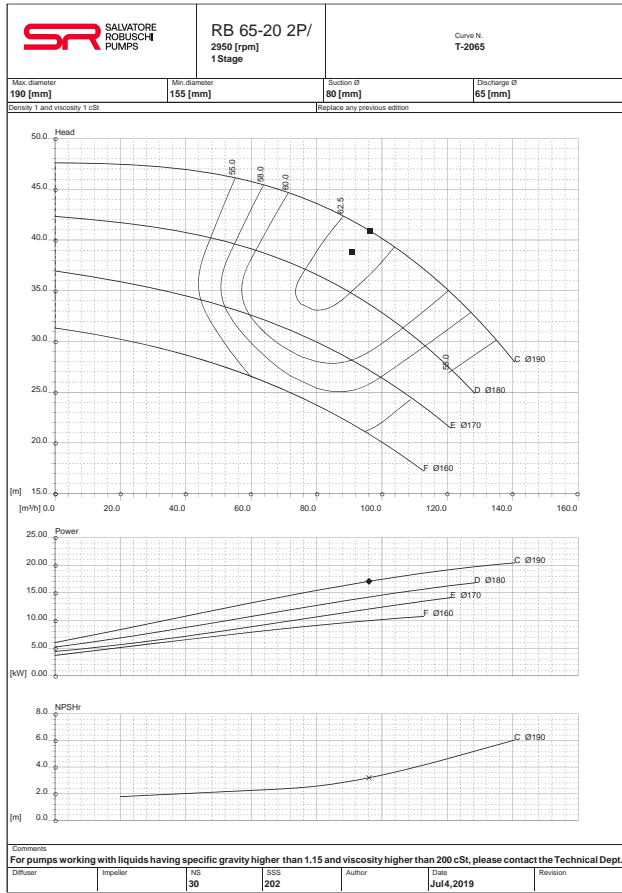

Curve prestazionali  
Performance curves

Girante multi-canale chiusa  
Closed multi-channel impeller

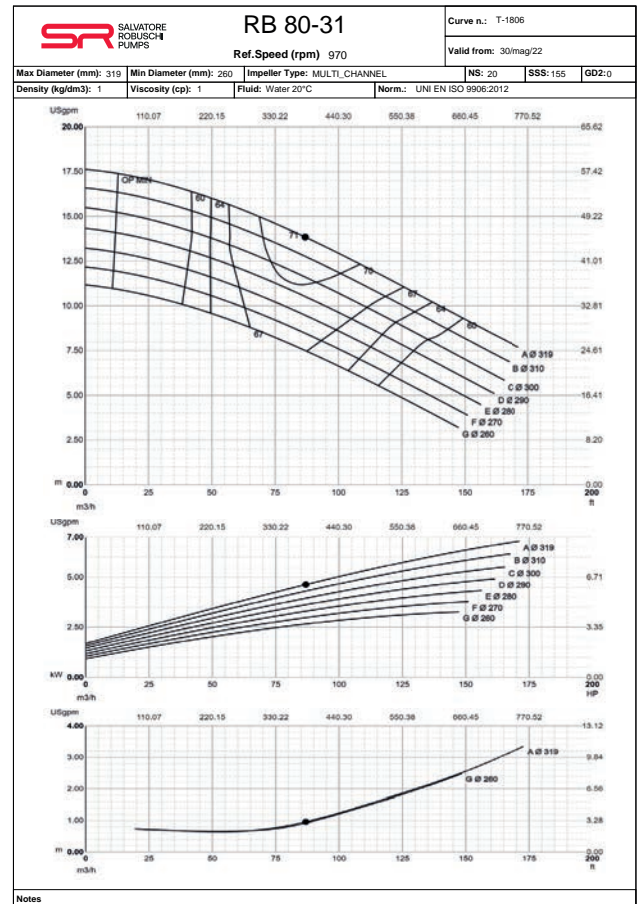
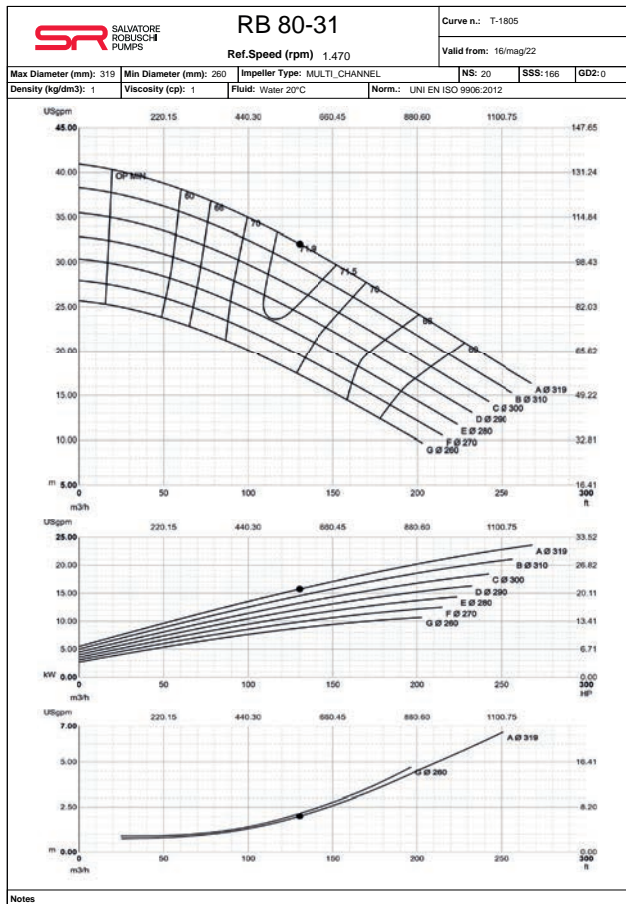
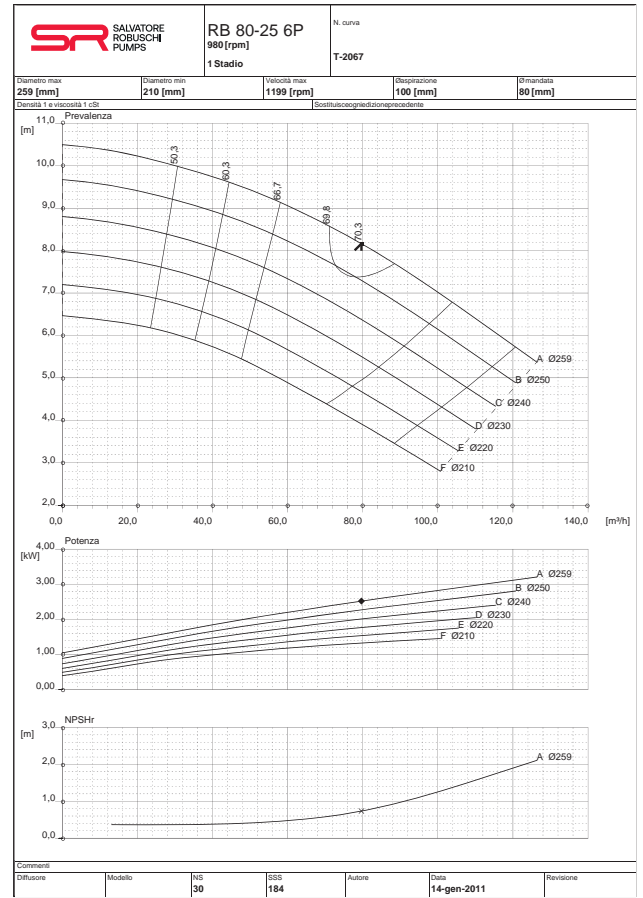
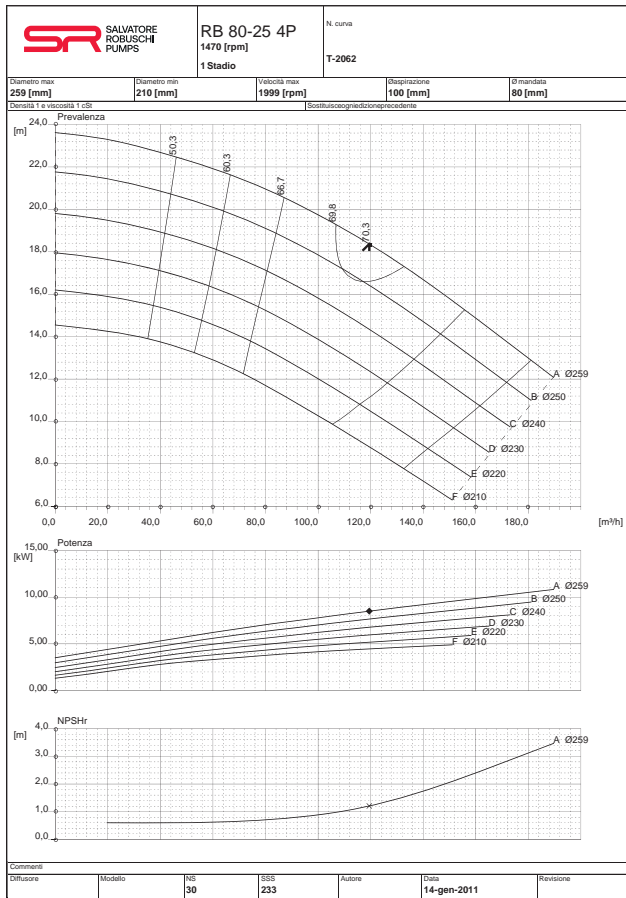

Curve prestazionali  
Performance curves

Girante multi-canale chiusa  
Closed multi-channel impeller

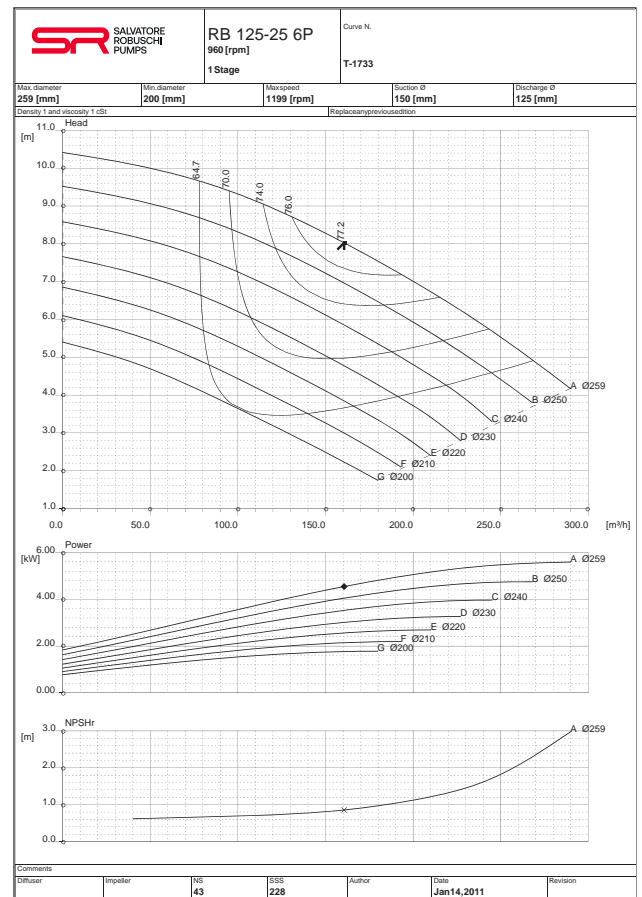
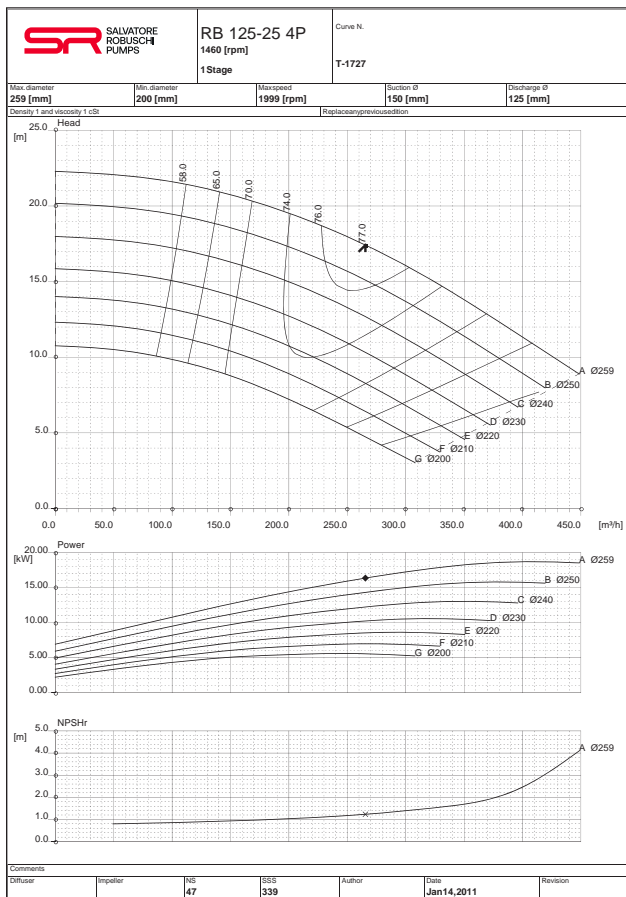
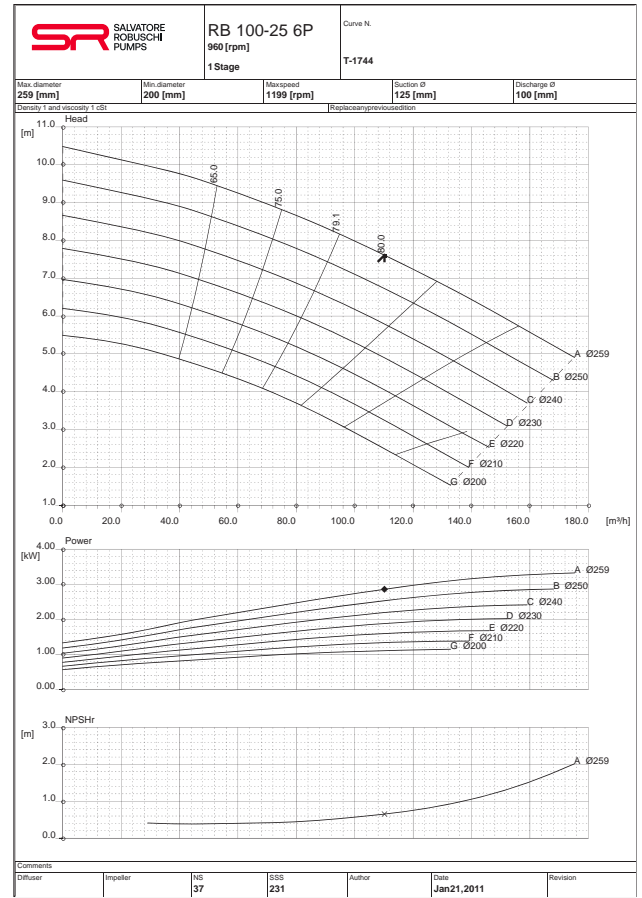
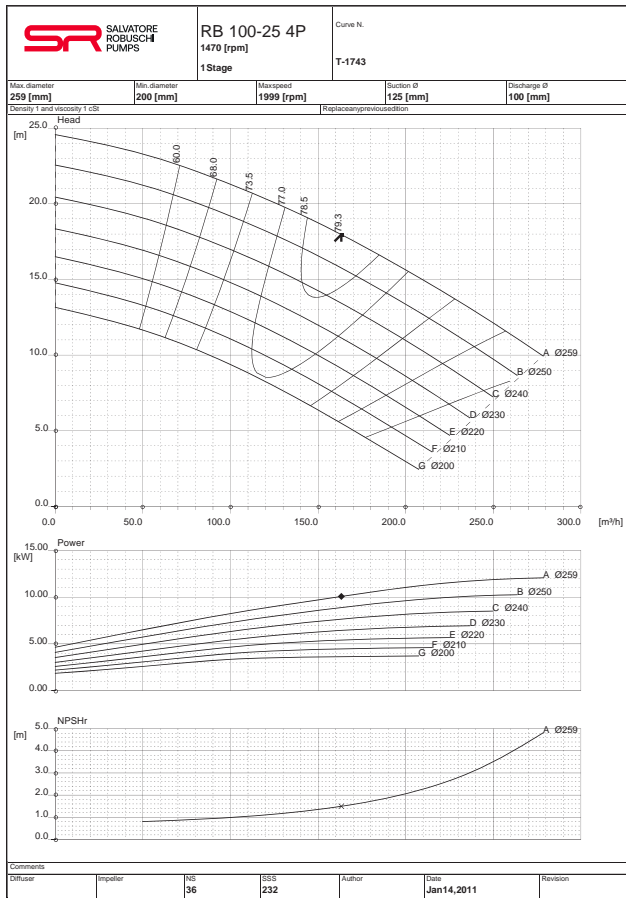

Curve prestazionali  
Performance curves

Girante multi-canale chiusa  
Closed multi-channel impeller

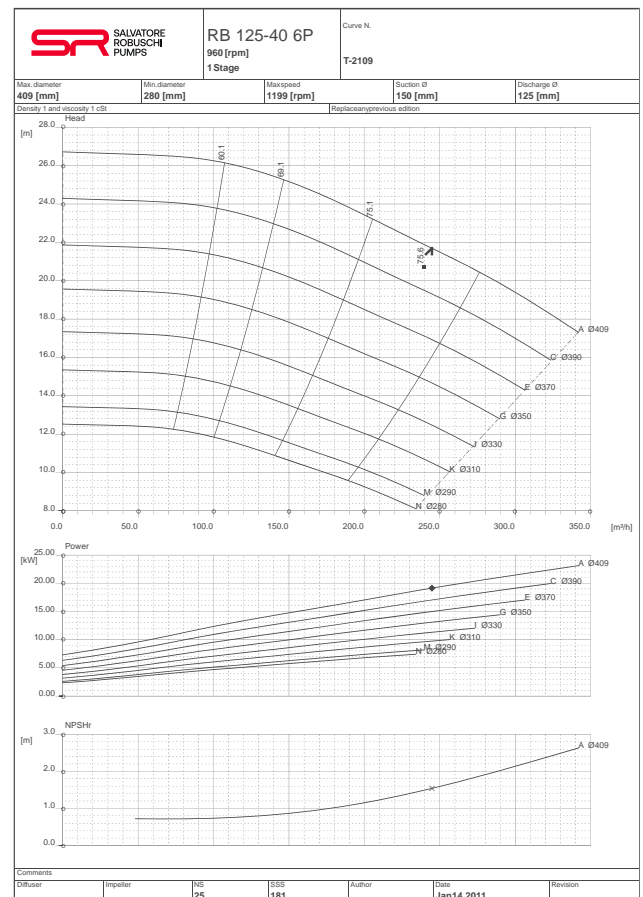
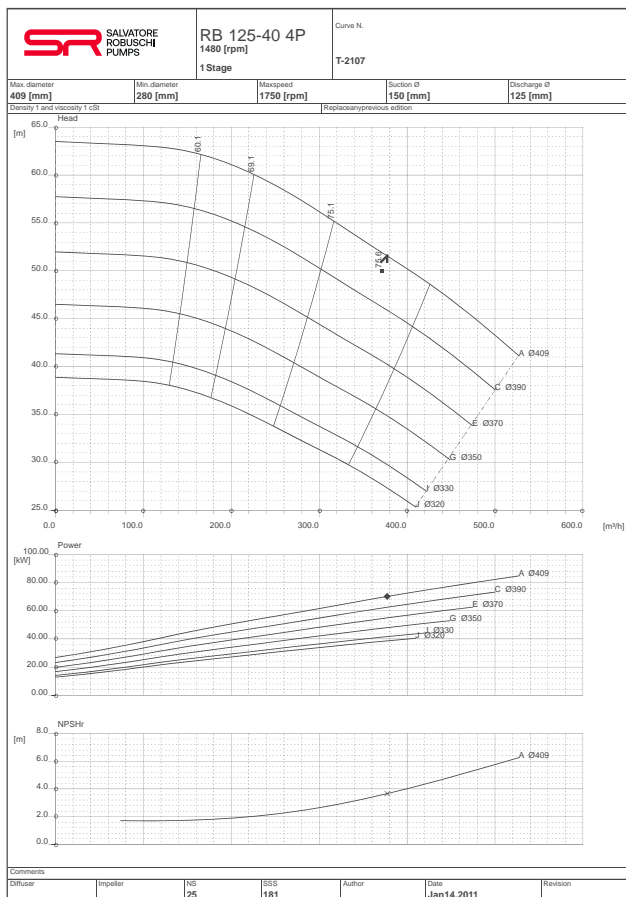
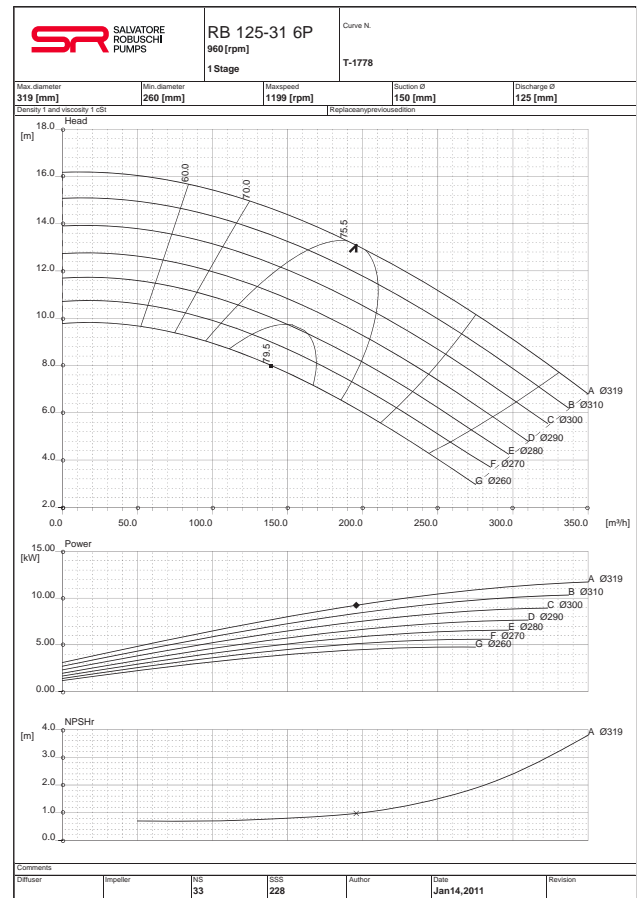
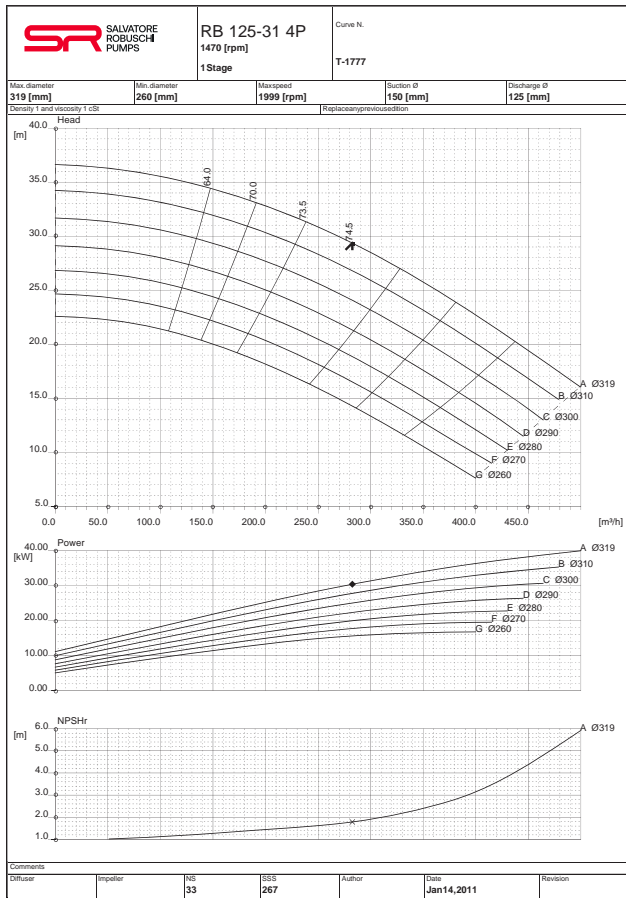

Curve prestazionali  
Performance curves

Girante multi-canale chiusa  
Closed multi-channel impeller

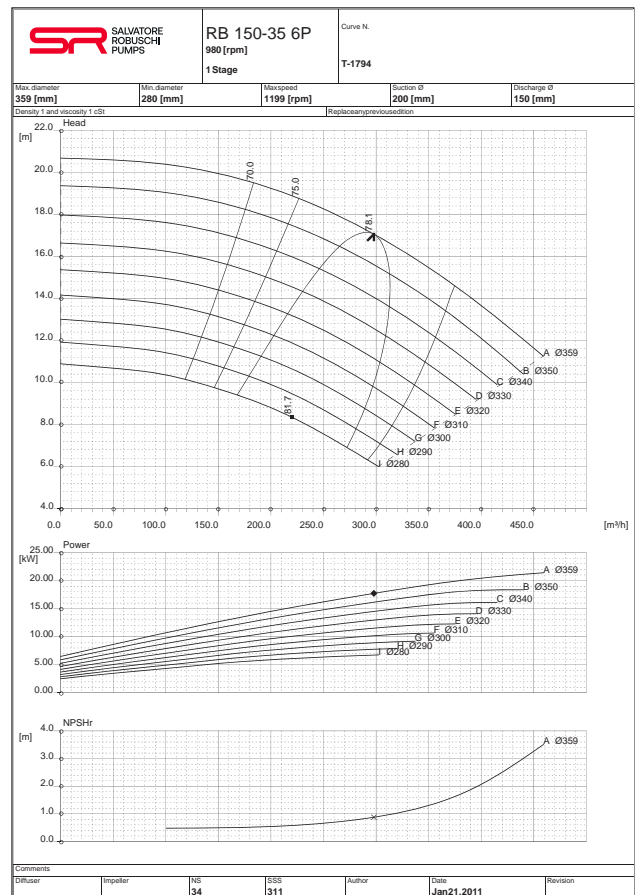
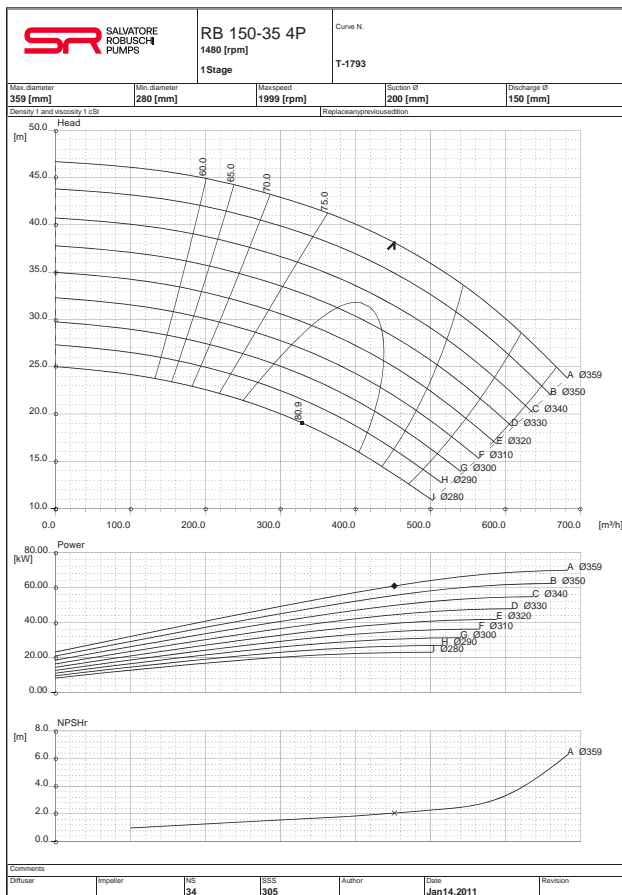
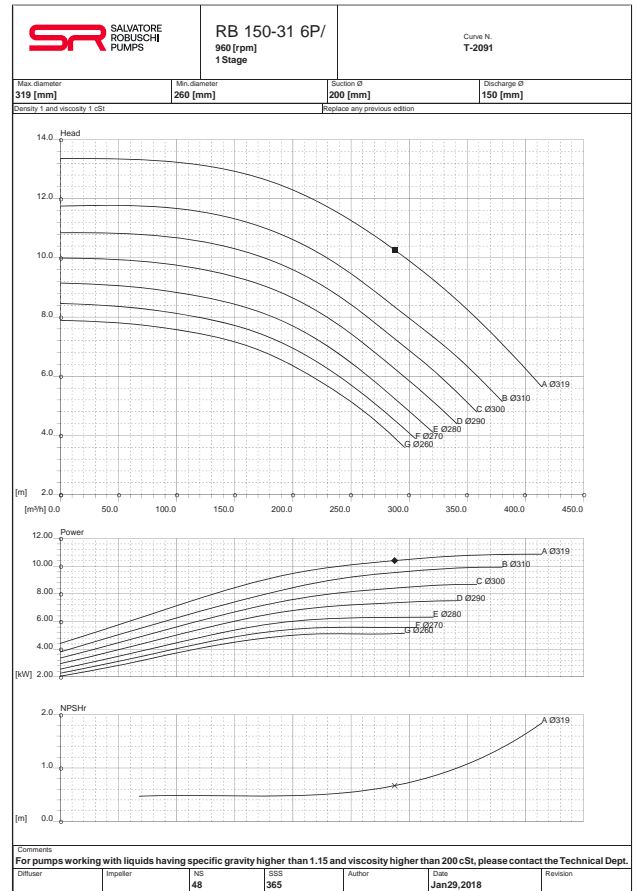
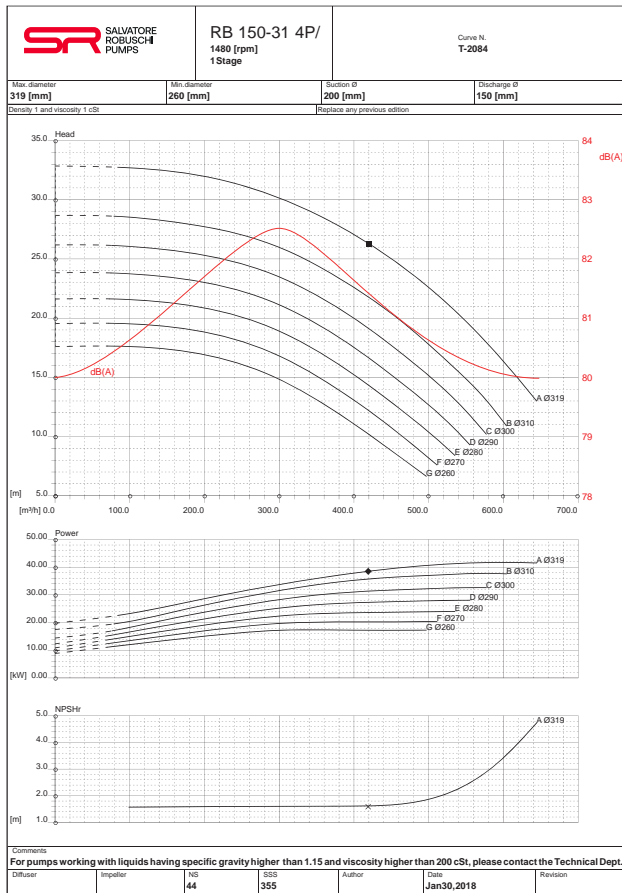

Curve prestazionali  
Performance curves

Girante multi-canale chiusa  
Closed multi-channel impeller

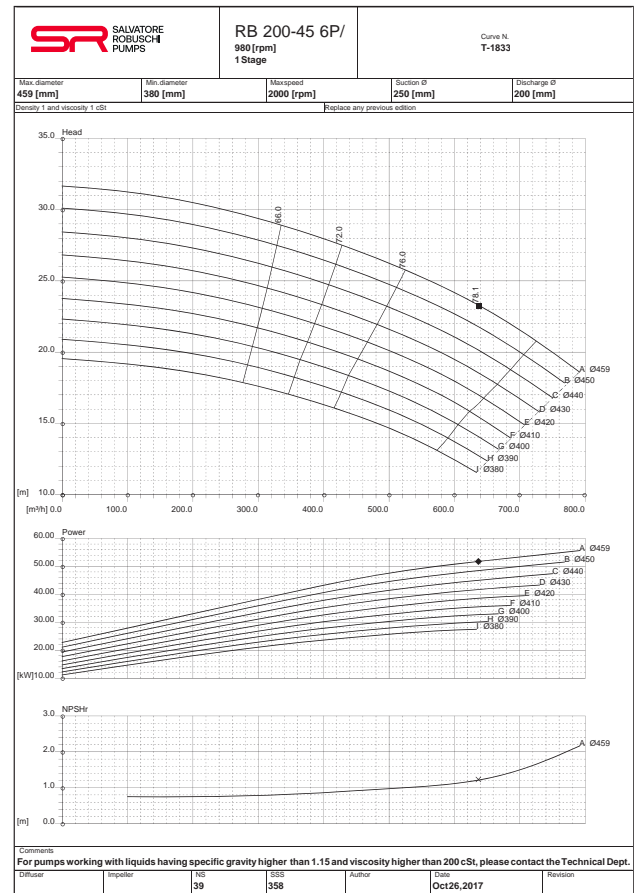
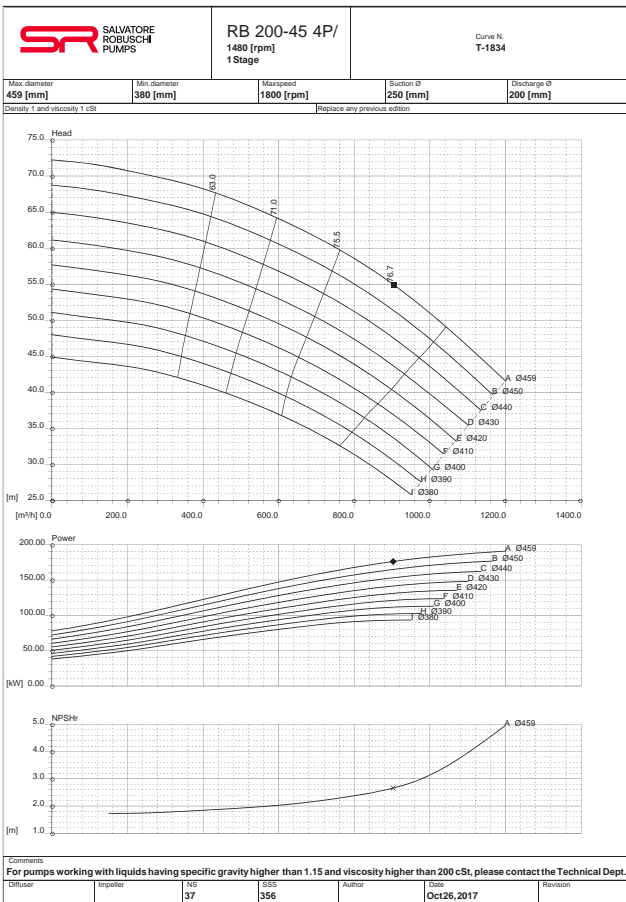
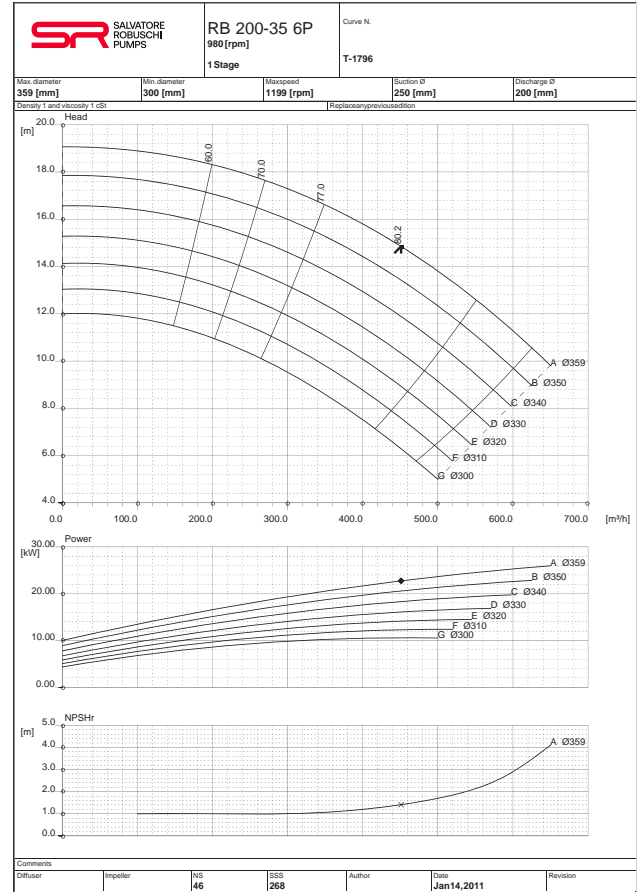
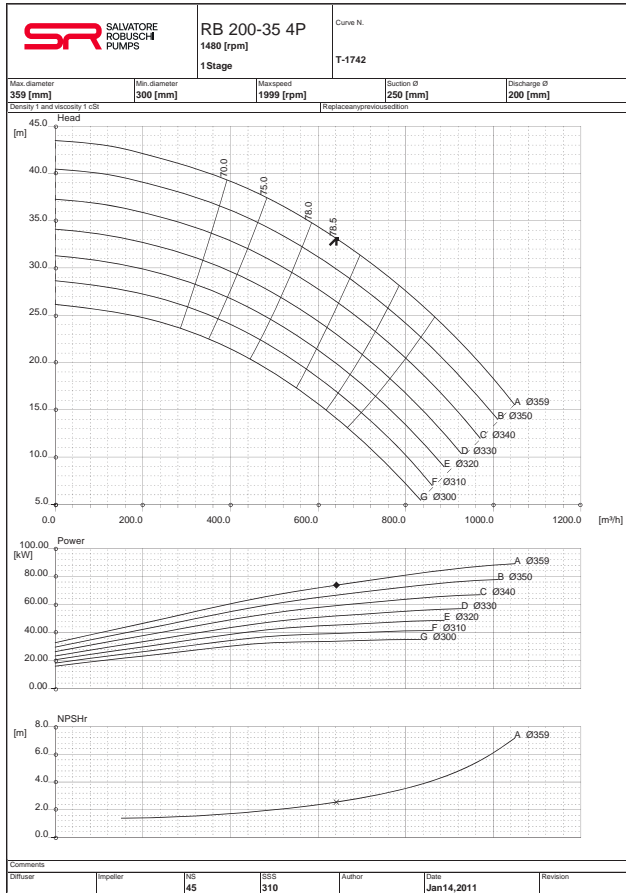

Curve prestazionali  
Performance curves

Girante multi-canale chiusa  
Closed multi-channel impeller

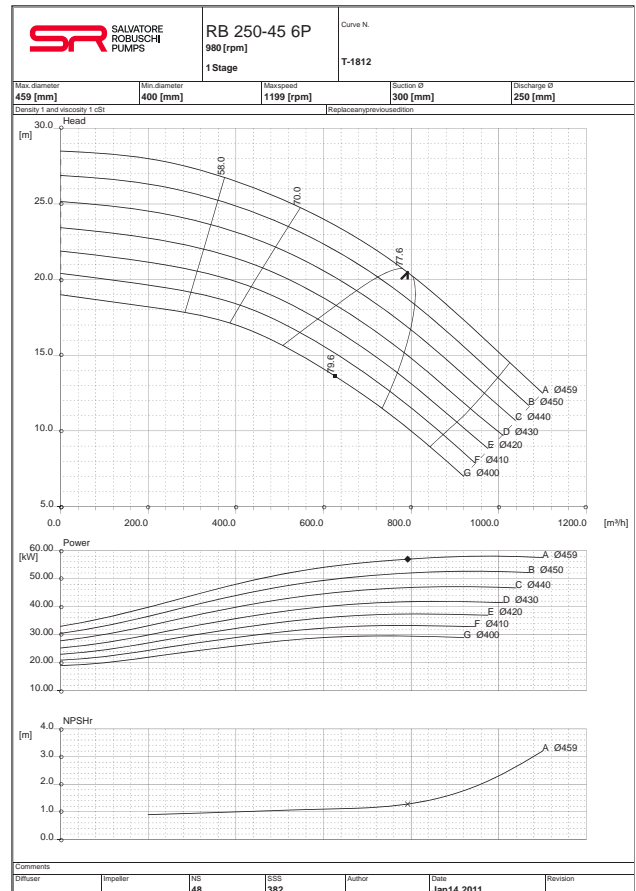
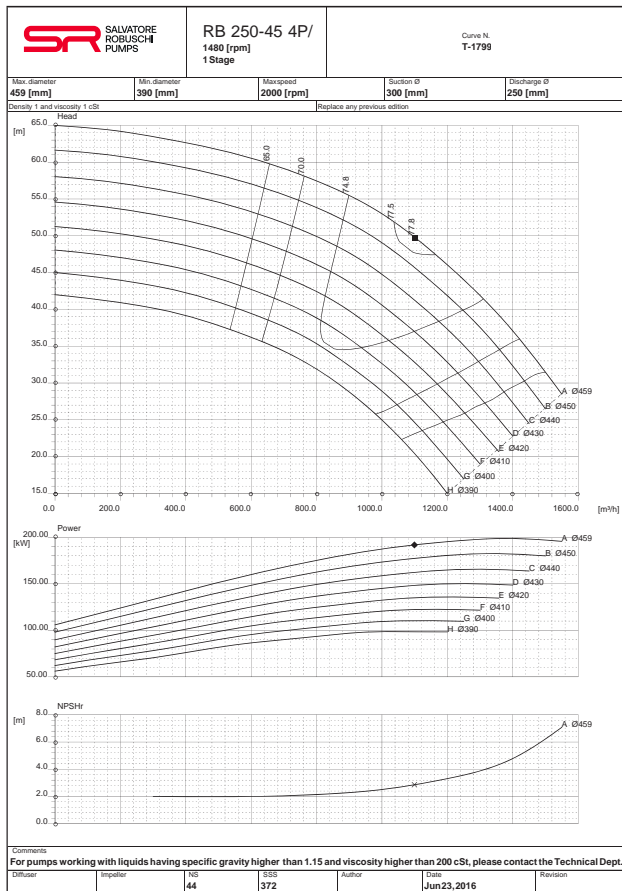
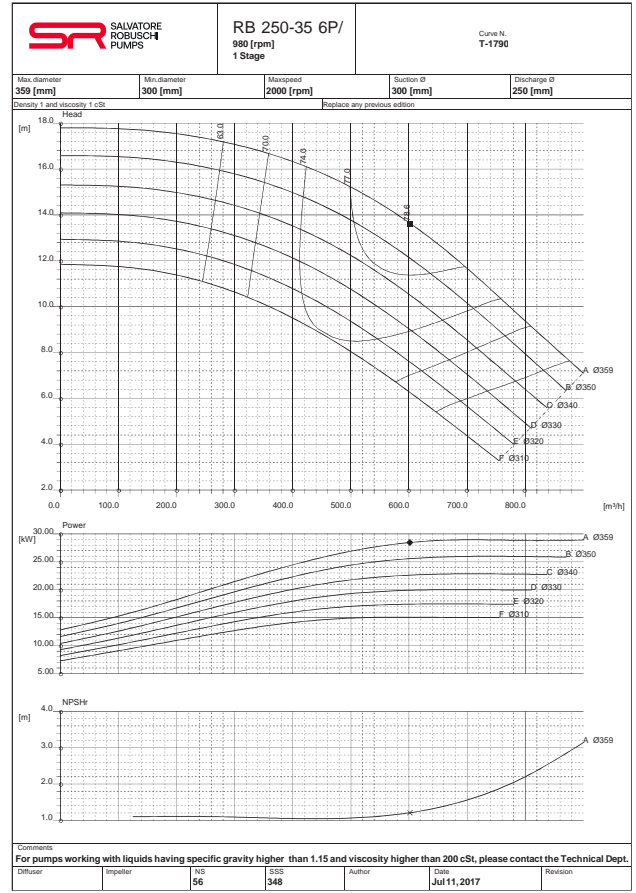
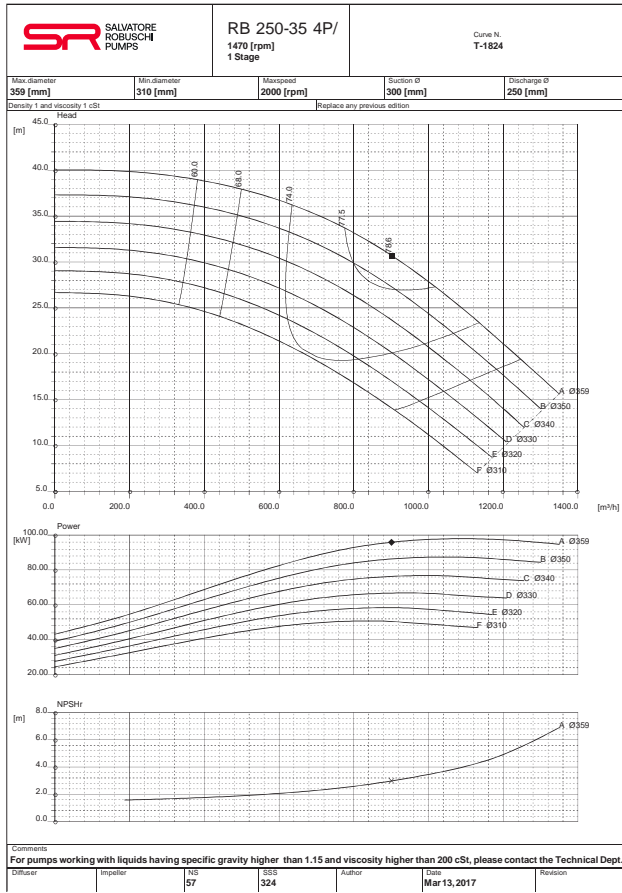

Curve prestazionali  
Performance curves

Girante multi-canale chiusa  
Closed multi-channel impeller

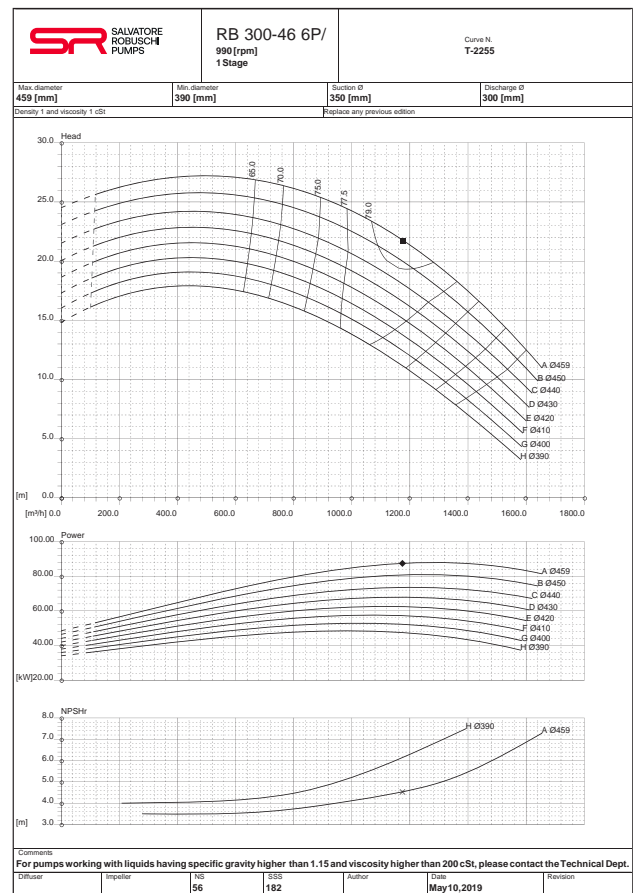
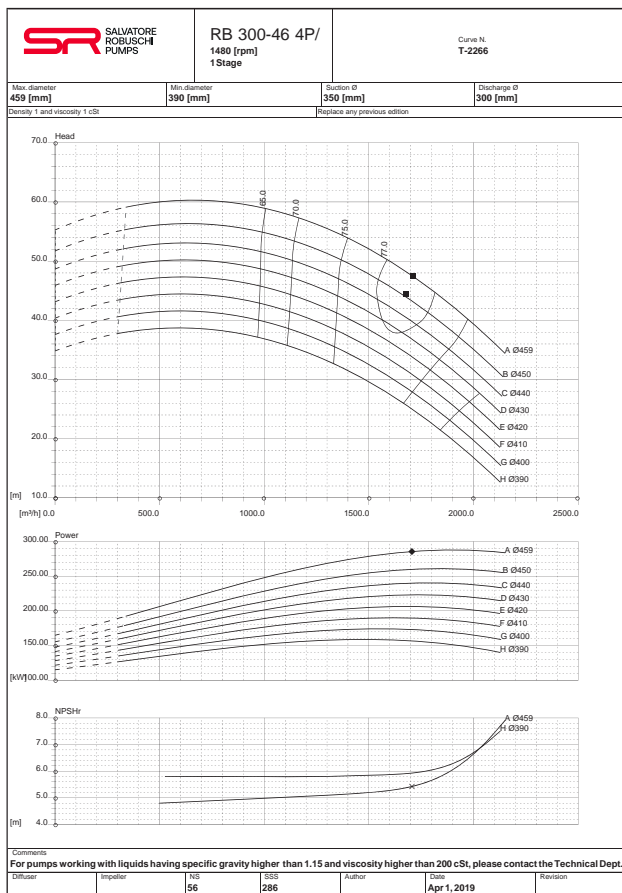
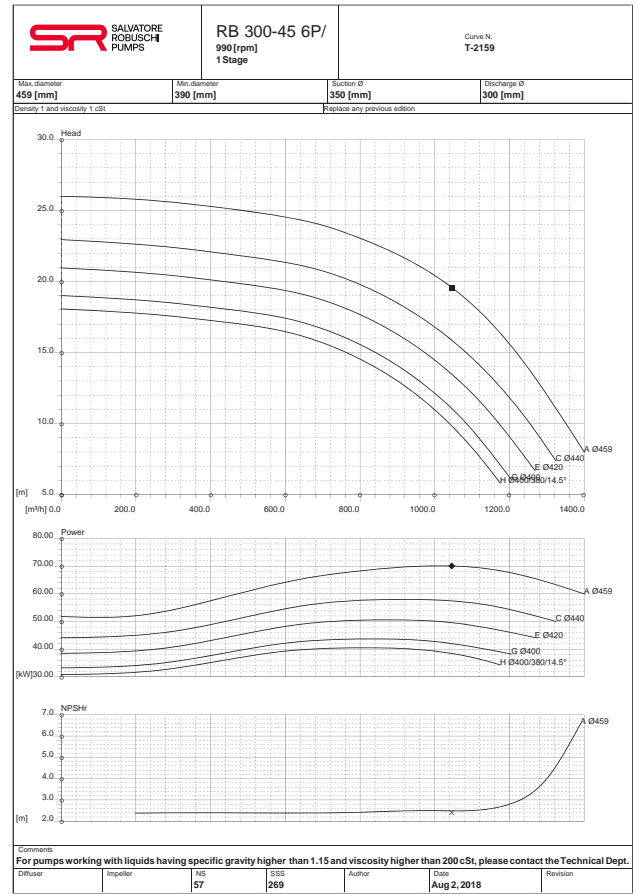
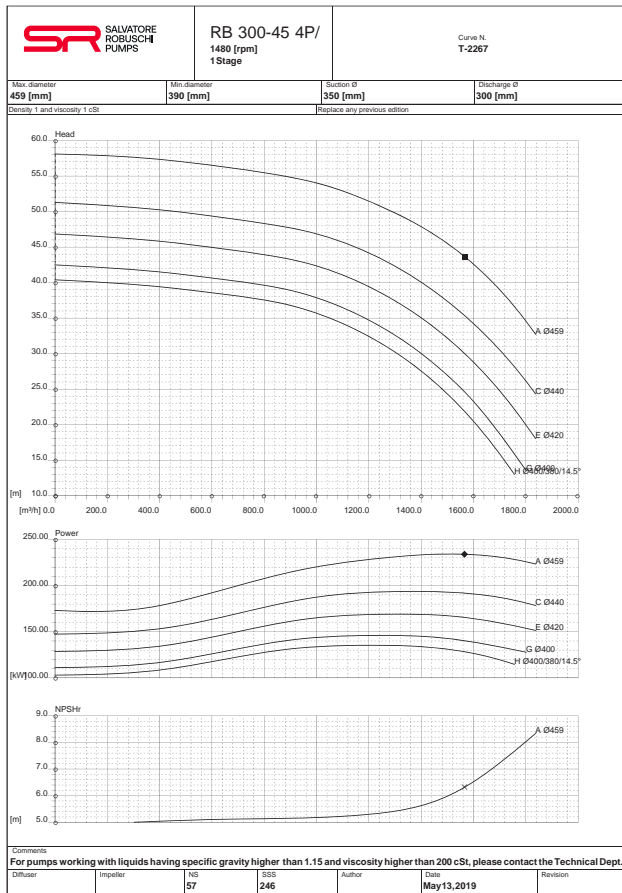

Curve prestazionali  
Performance curves

Girante multi-canale chiusa  
Closed multi-channel impeller

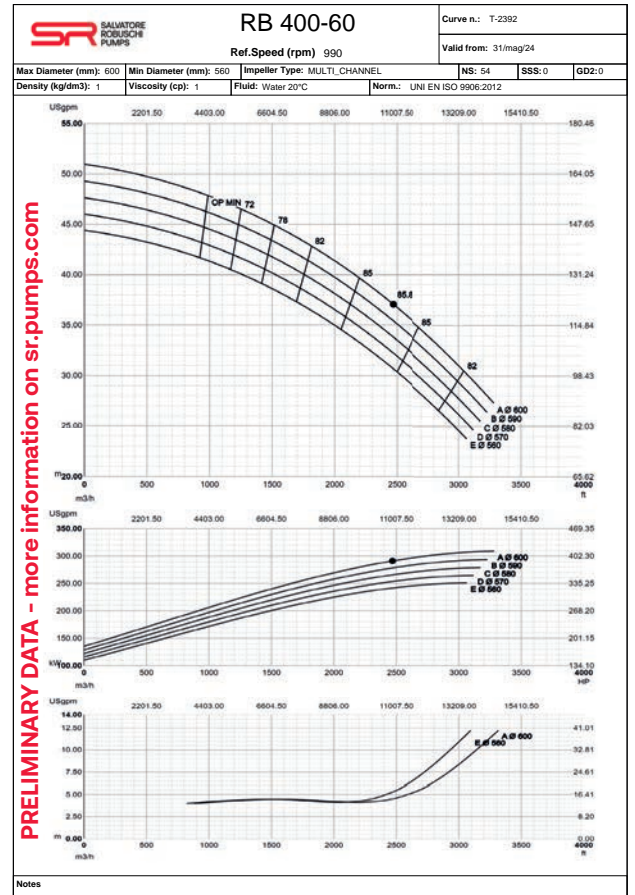
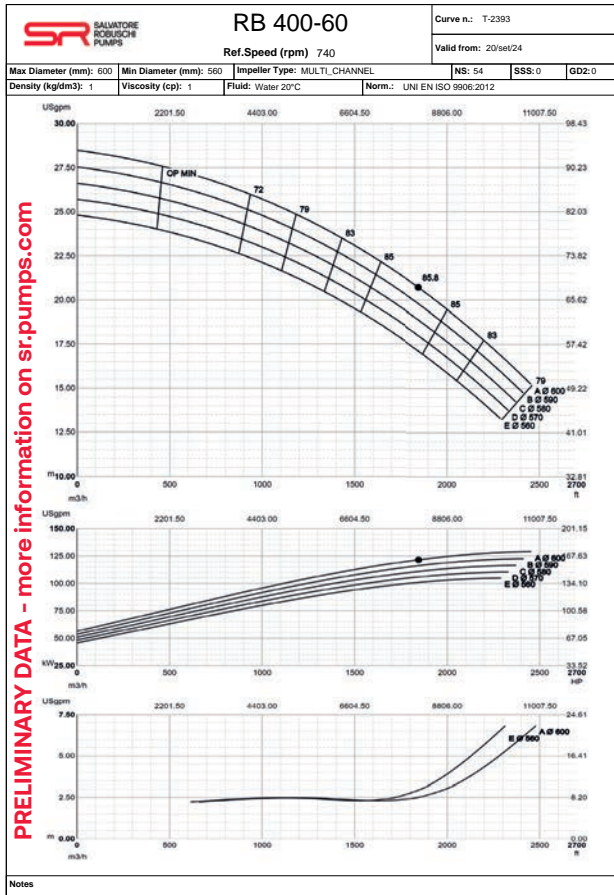

Campi di applicazione  
Coverage chart

Girante multi-canale aperta  
Open multi-channel impeller

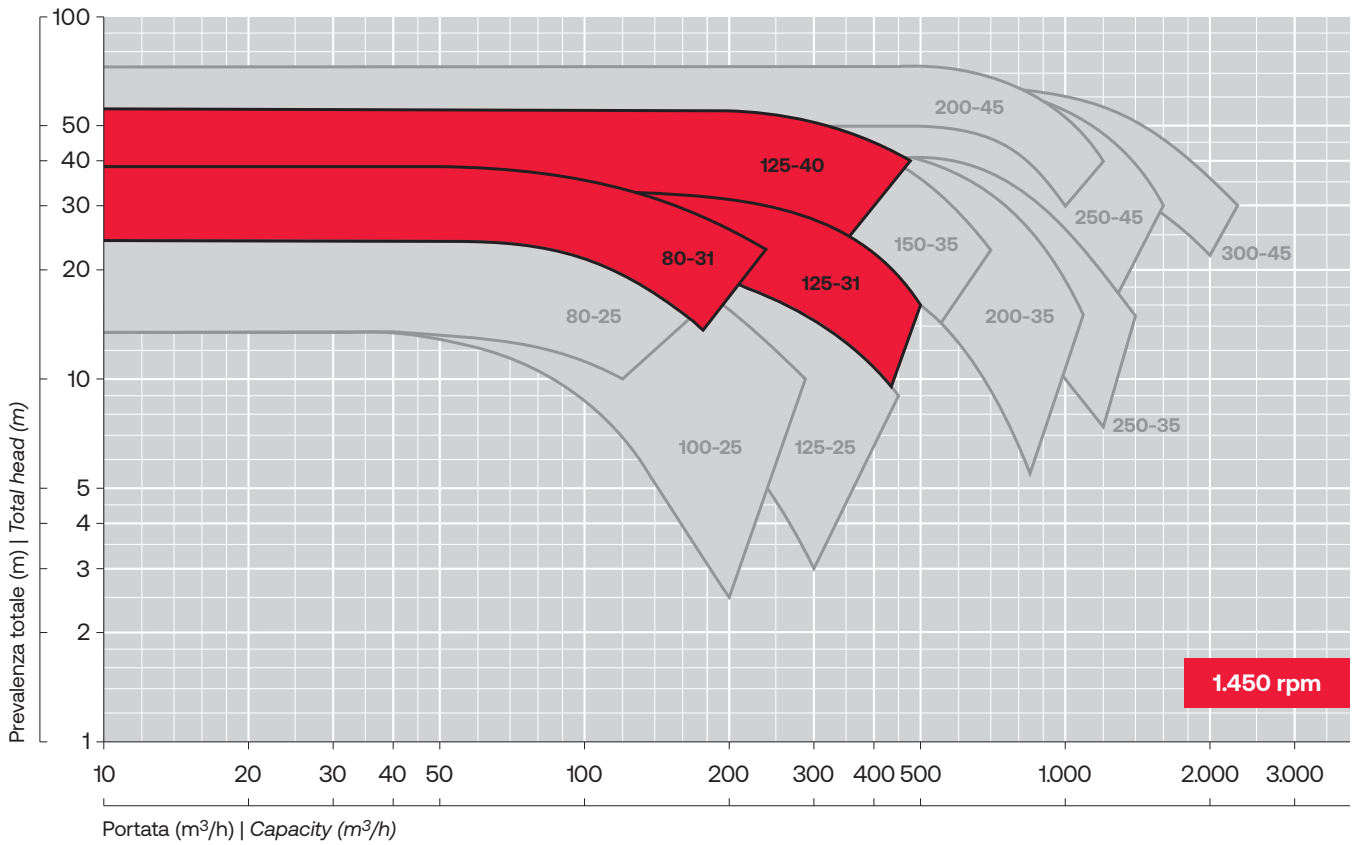

● IN PROGRESS

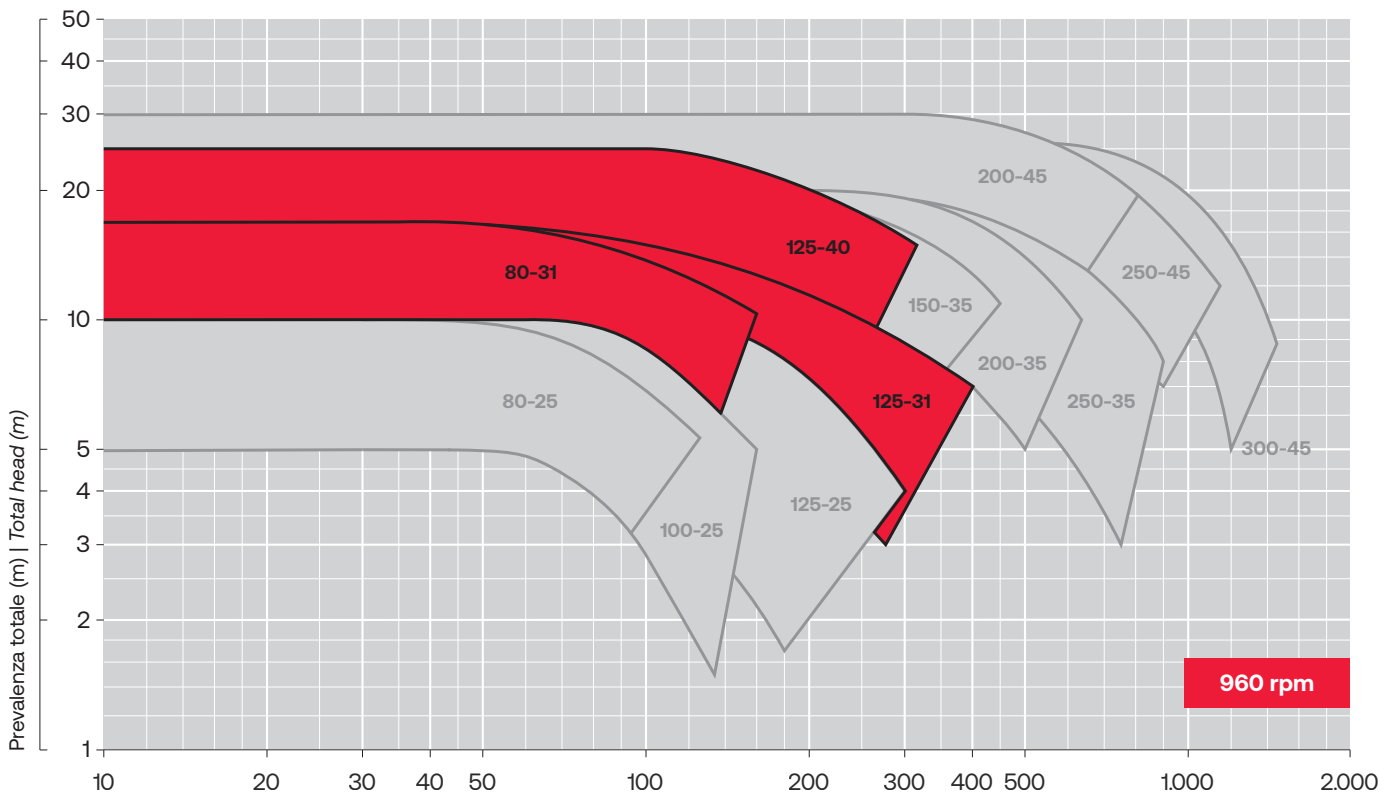

Curve prestazionali  
Performance curves

Girante multi-canale aperta  
Open multi-channel impeller

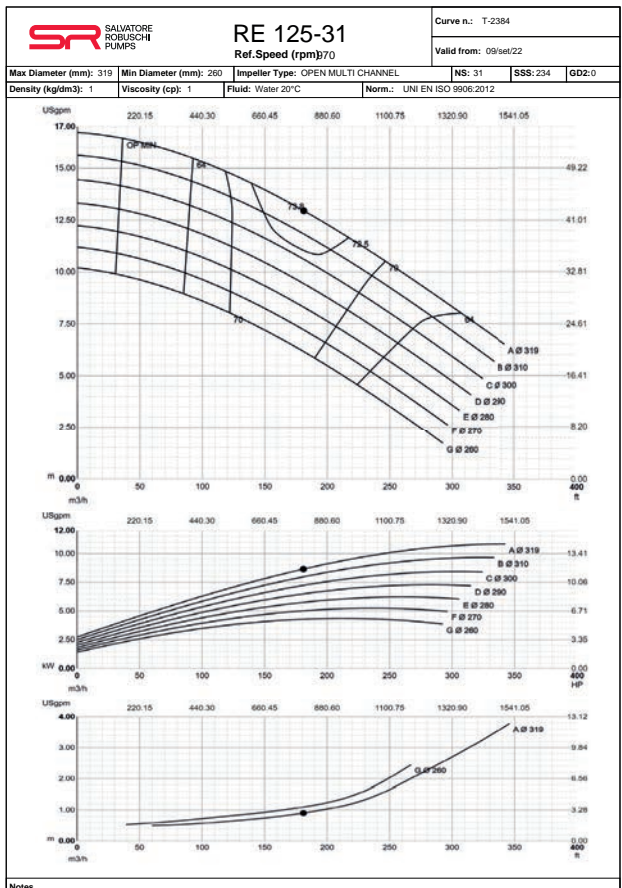
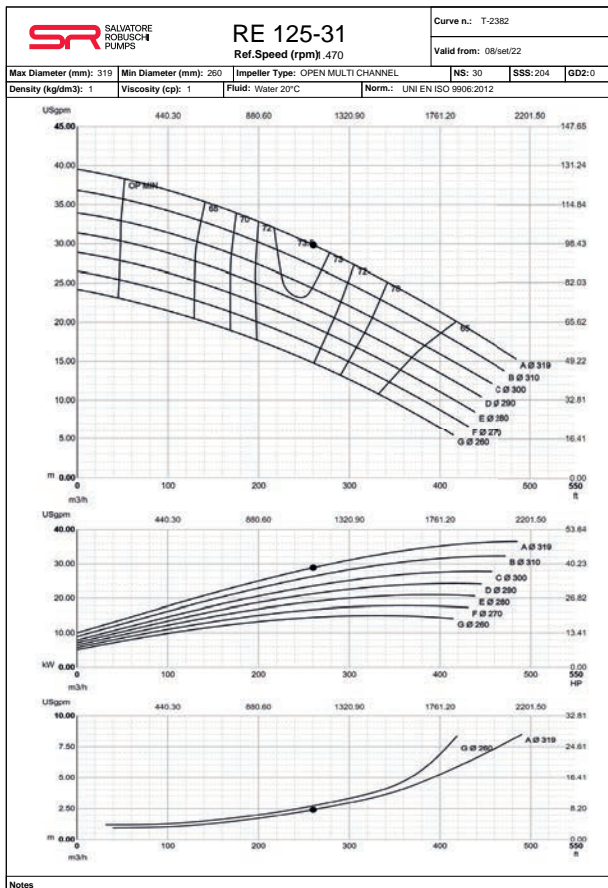
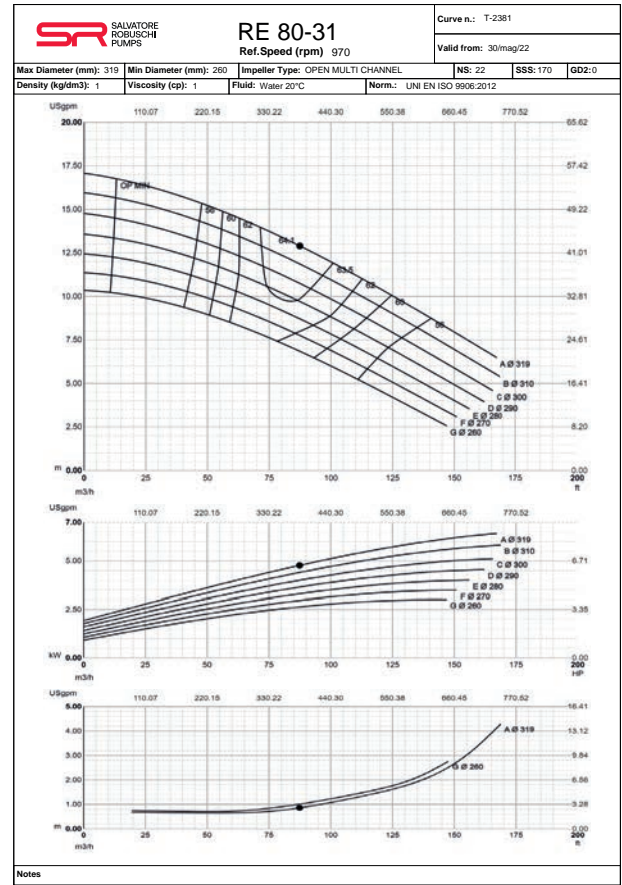
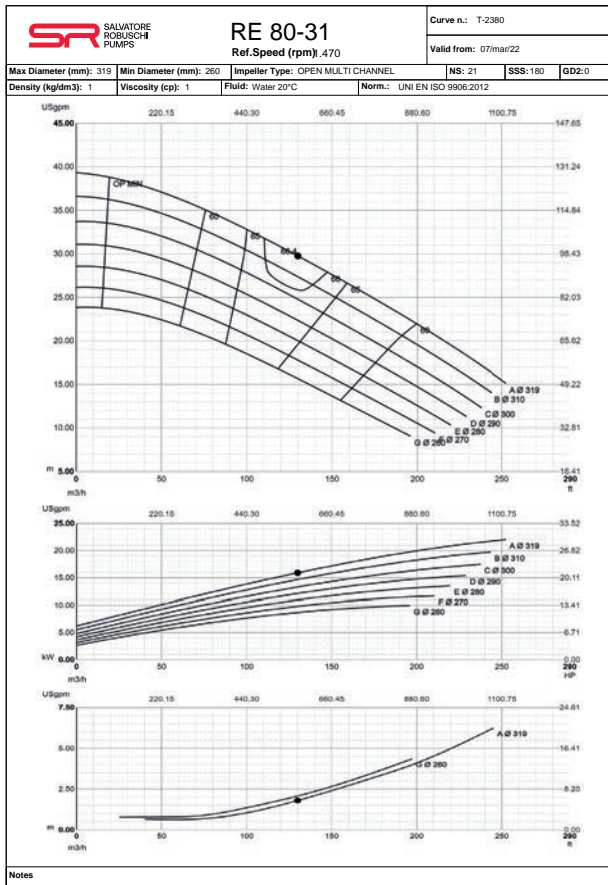

Curve prestazionali  
Performance curves

Girante multi-canale aperta  
Open multi-channel impeller

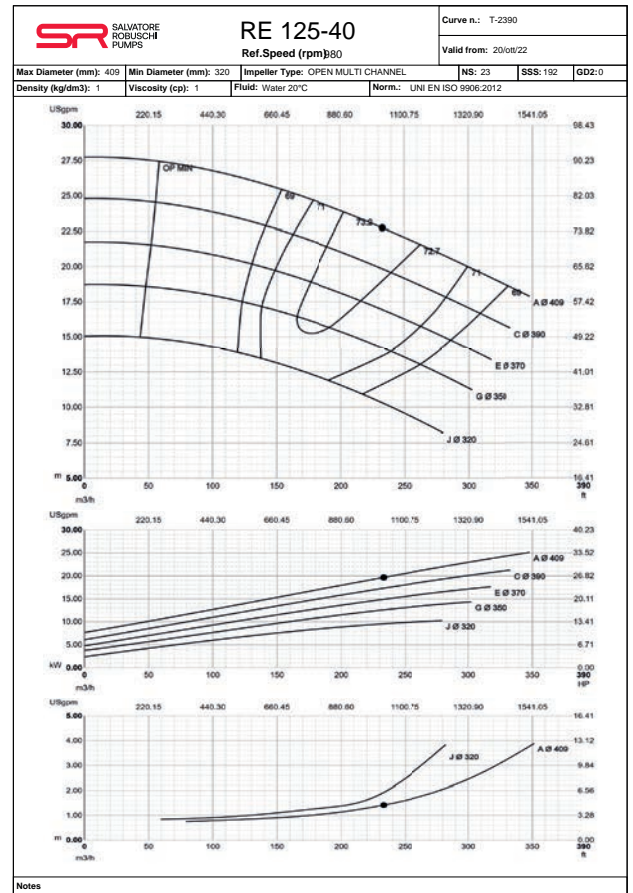
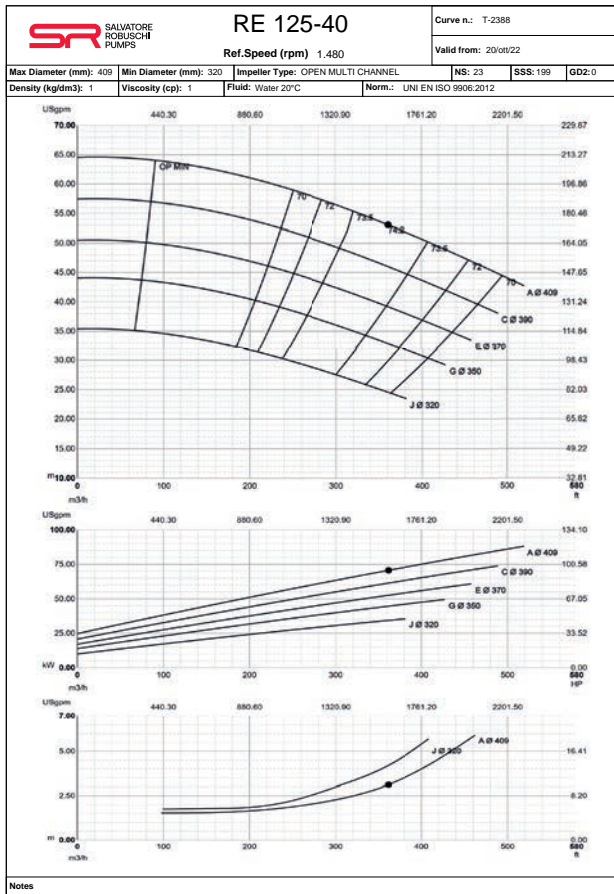

N° parte Part No.	Descrizione Description	Numero di pompe Number of pumps							
		1	2	3	4	5	dal 6 al 7 from 6 to 7	dal 8 al 9 from 8 to 9	10 e superiori 10 and above
210	Albero Shaft	1	1	1	1	2	2	2	20%
230	Girante Impeller	1	1	1	1	2	2	2	20%
320.1	Cuscinetti (Set) Bearing (Set)	1	1	2	2	2	2	3	25%
320.2									
502.1	Anello usura Wear ring	1	1	1	1	2	2	2	20%
135	Piastra usura Wear plate	1	1	1	1	2	2	2	20%
524	Camicia albero Shaft sleeve	1	2	2	2	3	3	4	50%
506	Anello paraspruzzi Deflector	1	1	1	1	2	2	2	20%
507	V.ring V.ring	1	1	1	1	2	2	2	20%
400.1	Guarnizioni idrauliche (Set) Hydraulic gaskets (Set)	2	4	4	5	6	8	8	80%
400.4									
400.5									
400.6									
400.7									
412.3									
400.2	Guarnizioni supporto (Set) e paraoli (Set) Housing gaskets (Set) and oil seals (Set)	2	4	4	5	6	8	8	80%
400.3									
420.1									
420.2									
861.3	Parastrappi giunto di trasmissione (Set) Transmission coupling clamps (Set)	2	4	4	5	6	8	8	80%
<b>Per pompe con tenute meccaniche</b> <i>For pumps with mechanical seals</i>									
433.1	Tenuta meccanica completa (Set) Complete mechanical seal (Set)	1	2	2	2	3	3	4	40%
433.2									
<b>Per pompe con baderne</b> <i>For pumps with packings glands</i>									
542	Bussola di fondo Bottom sleeve	1	1	1	1	2	2	2	20%
461	Baderne (Set) Packing glands (Set)	2	4	4	6	6	6	8	100%

N° parte Part No.	Descrizione Description	Numero di pompe Number of pumps							
		1	2	3	4	5	dal 6 al 7 from 6 to 7	dal 8 al 9 from 8 to 9	10 e superiori 10 and above
400.2	Guarnizioni supporto (Set) <i>Housing gaskets (Set)</i>	2	4	4	5	6	8	8	80%
400.3									
420.1									
420.2									
400.1	Guarnizioni idrauliche (Set) <i>Hydraulic gaskets (Set)</i>	2	4	4	5	6	8	8	80%
400.4									
400.5									
400.6									
400.7									
412.3									
507	V.ring <i>V.ring</i>	1	1	1	1	2	2	2	20%
524	Camicia albero <i>Shaft sleeve</i>	1	2	2	2	3	3	4	50%
<b>Per pompe con tenute meccaniche</b> <i>For pumps with mechanical seals</i>									
433.1	Tenuta meccanica completa (Set) <i>Complete mechanical seal (Set)</i>	1	2	2	2	3	3	4	40%
433.2									
<b>Per pompe con baderne</b> <i>For pumps with packings glands</i>									
461	Baderne (Set) <i>Packing glands (Set)</i>	2	4	4	6	6	6	8	100%

Grid of dots for notes.



**Salvatore Robuschi & C. srl**  
via Emilio Gino Segrè 11/a  
43122 Parma | Italy

t +39 (0)521 606285  
f +39 (0)521 606278

salvatorerobuschi.com  
srpumps.com

sr@salvatorerobuschi.com

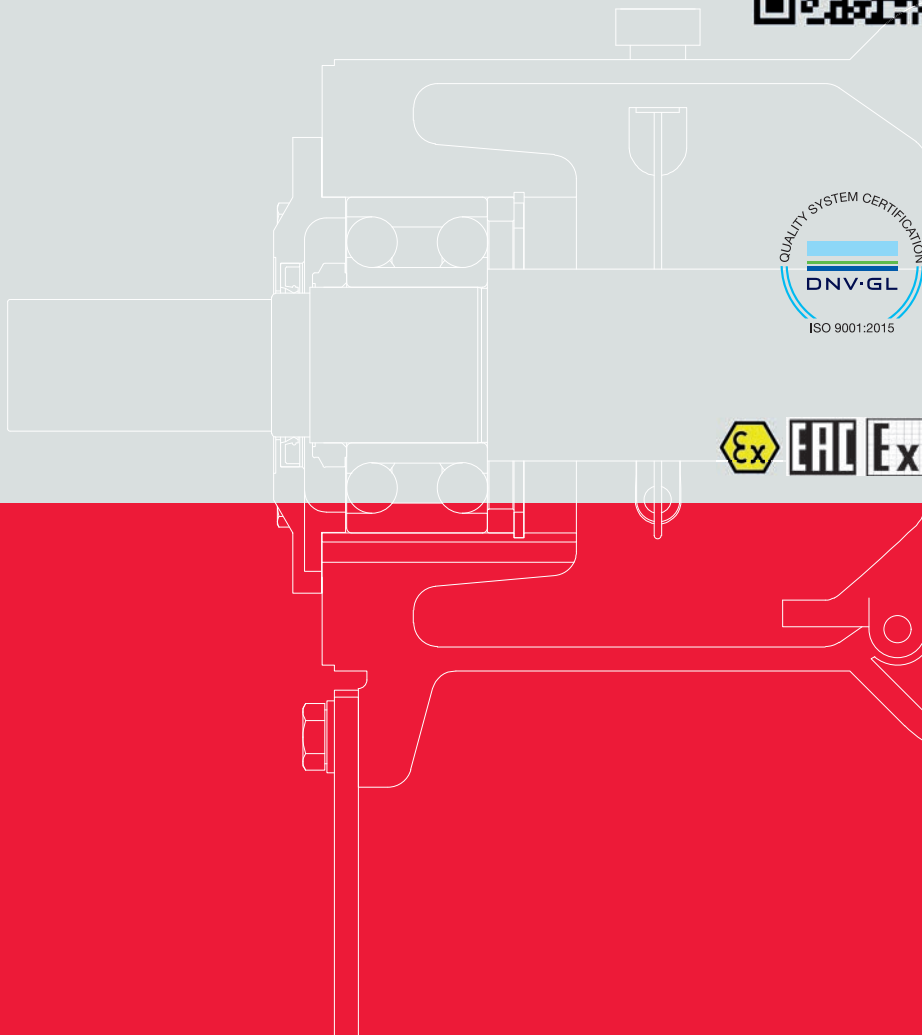

**RB - RE**